

Fiche Quid

OMRON

OMRON ELECTRONICS S.A.S.
14 Rue de Lisbonne
93561 Rosny-sous-Bois cedex

N° Indigo 0 825 825 679
0,15€ TTC/mn.

| | |
|-----------|---|
| Référence | FQ câbles NQ |
| Révision | 1.0 |
| Auteur | JPV |
| Date | 17/07/2009 |
| +Support | http://support-omron.fr/Quid.html |

Câblage des terminaux NQ

I. Connexion au PC de programmation

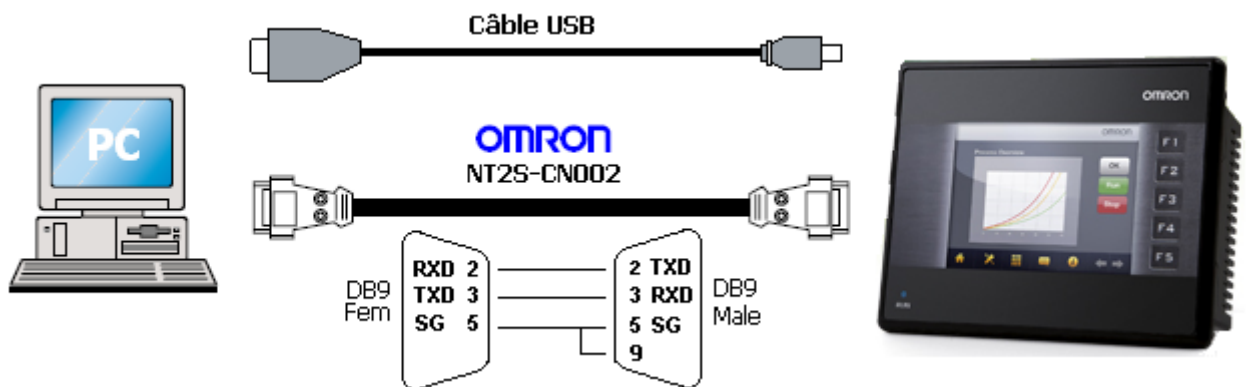

II. Connexion au port RS232C des API

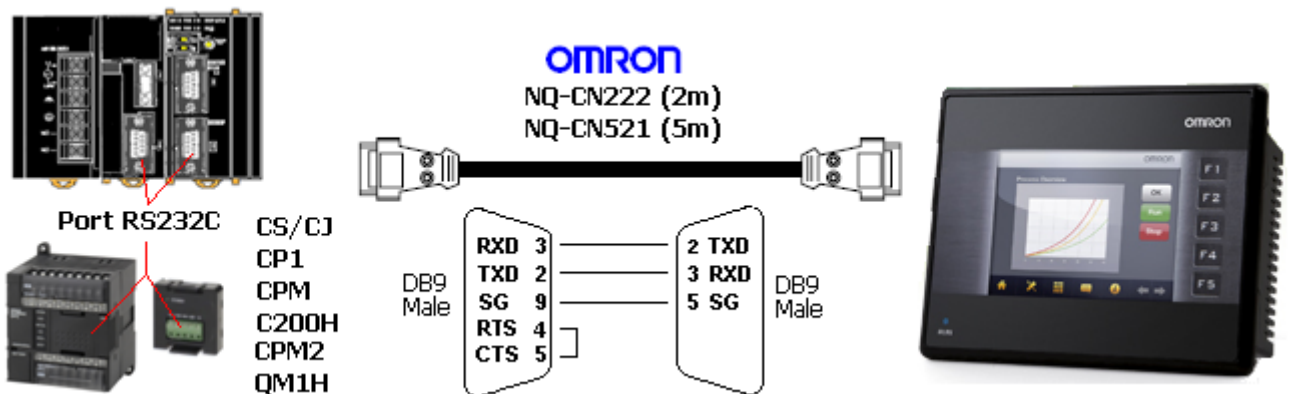

III. Connexion à un Variateur V1000 en RS422

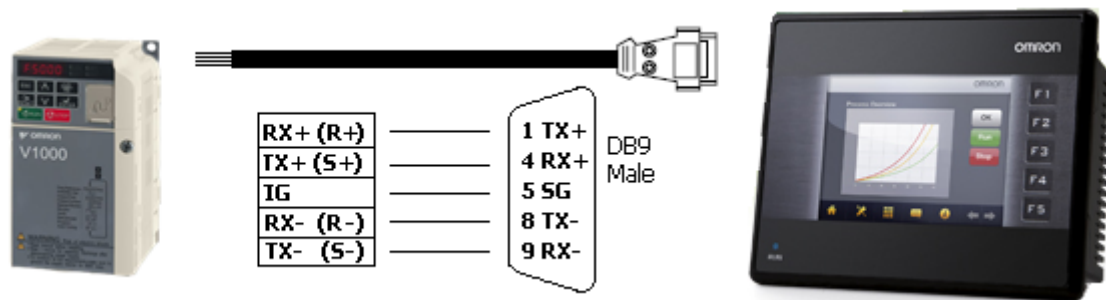

IV. Connexion à un variateur V1000 en RS485

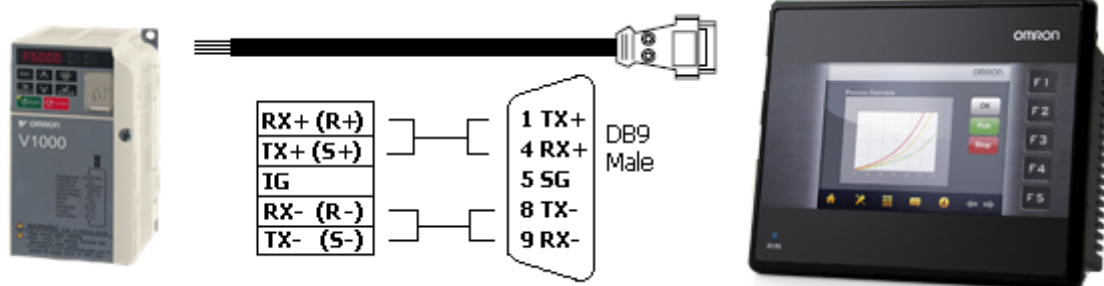

V. Connexion à un automate Schneider Modicon

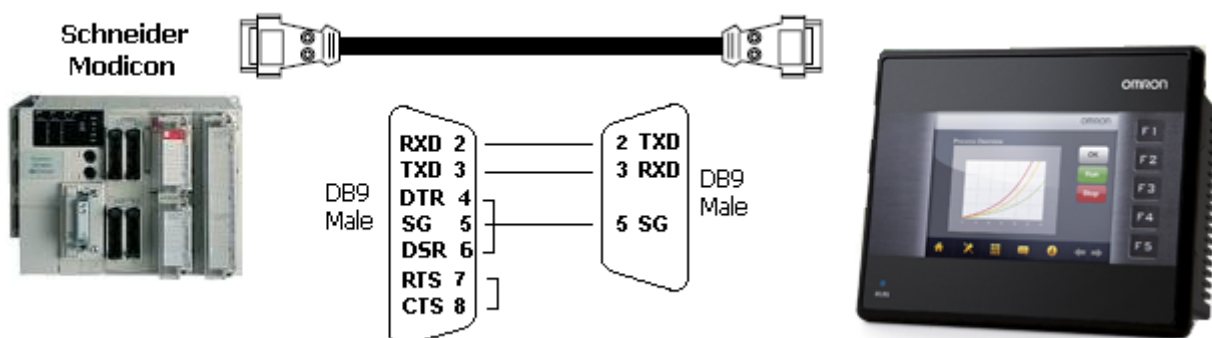

VI. Connexion à un automate AB SLC 500

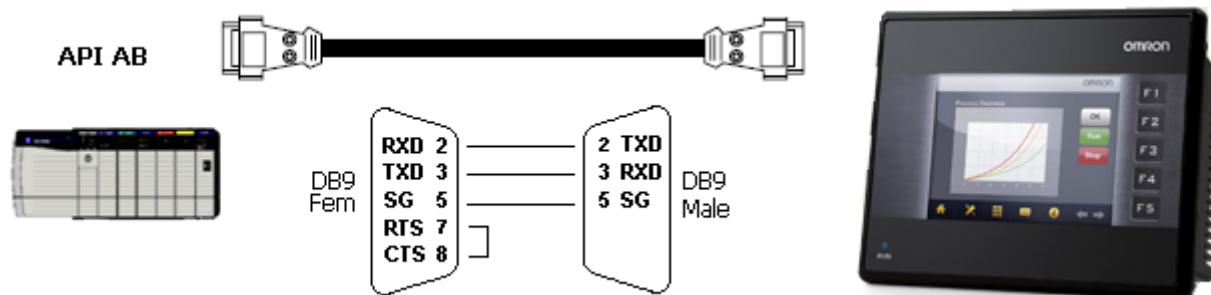

VII. Connexion à un automate Siemens

