

**SYSMAC**

**3G8F5-CLK11-E**

**3G8F5-CLK21-E**

**Controller Link Support Boards**

**OPERATION MANUAL**

**OMRON**

# SYSMAC 3G8F5-CLK11-E 3G8F5-CLK21-E Controller Link Support Boards

## Operation Manual

*Revised February 1999*

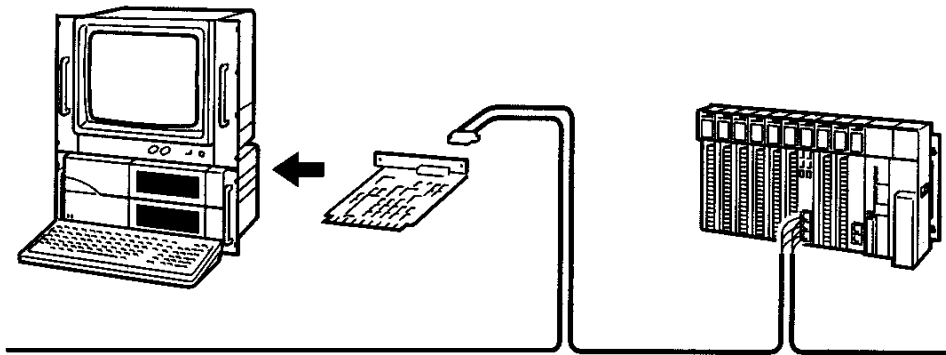



## **Notice:**

OMRON products are manufactured for use according to proper procedures by a qualified operator and only for the purposes described in this manual.

The following conventions are used to indicate and classify precautions in this manual. Always heed the information provided with them. Failure to heed precautions can result in injury to people or damage to property.

 **DANGER** Indicates an imminently hazardous situation which, if not avoided, will result in death or serious injury.

 **WARNING** Indicates a potentially hazardous situation which, if not avoided, could result in death or serious injury.

 **Caution** Indicates a potentially hazardous situation which, if not avoided, may result in minor or moderate injury, or property damage.

## **OMRON Product References**

All OMRON products are capitalized in this manual. The word “Unit” is also capitalized when it refers to an OMRON product, regardless of whether or not it appears in the proper name of the product.

The abbreviation “Ch,” which appears in some displays and on some OMRON products, often means “word” and is abbreviated “Wd” in documentation in this sense.

The abbreviation “PC” means Programmable Controller and is not used as an abbreviation for anything else.

## **Visual Aids**

The following headings appear in the left column of the manual to help you locate different types of information.

**Note** Indicates information of particular interest for efficient and convenient operation of the product.

**1, 2, 3...** 1. Indicates lists of one sort or another, such as procedures, checklists, etc.

## **© OMRON, 1997**

All rights reserved. No part of this publication may be reproduced, stored in a retrieval system, or transmitted, in any form, or by any means, mechanical, electronic, photocopying, recording, or otherwise, without the prior written permission of OMRON.

No patent liability is assumed with respect to the use of the information contained herein. Moreover, because OMRON is constantly striving to improve its high-quality products, the information contained in this manual is subject to change without notice. Every precaution has been taken in the preparation of this manual. Nevertheless, OMRON assumes no responsibility for errors or omissions. Neither is any liability assumed for damages resulting from the use of the information contained in this publication.

DOS, Windows and Microsoft C are registered trademarks of Microsoft Corporation.

IBM is a registered trademark of International Business Machines Corporation.

All other product names or company names that appear in this manual are trademarks or registered trademarks of each respective company.

# TABLE OF CONTENTS

<b>PRECAUTIONS</b> .....	
1 Intended Audience .....	
2 General Precautions .....	
3 Safety Precautions .....	
4 Operating Environment Precautions .....	
5 Application Precautions .....	
<b>SECTION 1</b>	
<b>Features</b> .....	
1-1 Overview .....	
1-2 Specifications and Configurations .....	
1-3 Basic Procedures .....	
1-4 Applications Precautions .....	
<b>SECTION 2</b>	
<b>Setting, Installing, and Wiring Boards</b> .....	
2-1 Installing the Support Board .....	
2-2 Connecting Wired-system Cables .....	
2-3 Connecting Optical-system Cables .....	
<b>SECTION 3</b>	
<b>Software Installation</b> .....	
3-1 Preparations .....	
3-2 Installation Method .....	
3-3 Confirming Normal Startup .....	
<b>SECTION 4</b>	
<b>Creating Applications</b> .....	
4-1 Basic Flow .....	
4-2 MS-C Library .....	
4-3 Driver Calls .....	
4-4 Sample Program .....	
<b>SECTION 5</b>	
<b>Commands and Driver Call Reference</b> .....	
5-1 Library Commands and Driver Call List .....	
5-2 C Commands .....	
5-3 Driver Calls .....	
<b>SECTION 6</b>	
<b>Data Links</b> .....	
6-1 What Are Data Links? .....	
6-2 Setting Data Links .....	
6-3 Starting and Stopping Data Links .....	
6-4 Checking Data Link Status .....	
<b>SECTION 7</b>	
<b>Message Service</b> .....	
7-1 Introduction .....	
7-2 FINS Command/Response Format .....	
7-3 Commands and Responses for the Support Board .....	
7-4 Response Codes .....	

# TABLE OF CONTENTS

## SECTION 8

### Network Interconnections .....

- 8-1 What is Network Interconnection? .....
- 8-2 Routing Tables .....
- 8-3 Setting Routing Tables .....

## SECTION 9

### Communications Timing .....

- 9-1 Network Parameters .....
- 9-2 Communications Cycle Time .....
- 9-3 Data Link I/O Response Time .....
- 9-4 Message Service Delay Times .....

## SECTION 10

### Troubleshooting and Maintenance .....

- 10-1 Troubleshooting Using Indicators .....
- 10-2 Status Information and Troubleshooting .....
- 10-3 Error Log .....
- 10-4 Cleaning and Inspection .....
- 10-5 Handling Precautions .....

## Appendix

- Standard Models .....

## Index .....

## Revision History .....

## About this Manual:

This manual describes the installation, setup, and operation of the 3G8F5-CLK11-E/CLK21-E Controller Link Support Boards and includes the sections described below. Controller Link Support Boards are used to connect IBM PC/AT or compatible computers to a Controller Link Network. The following three manuals are directly related to application of the Controller Link Network.

Name	Contents	Cat. No. (suffixes omitted)
SYSMAC 3G8F5-CLK11-E, 3G8F5-CLK21-E Controller Link Support Boards Operation Manual (this manual)	Installation, setup, and operating procedures for Controller Link Support Boards. Controller Link Support Boards are used to connect IBM PC/ATs or compatibles to a Controller Link Network.	W307
SYSMAC C200HW-ZW3AT2-E, 3G8F5-CLK11-E/CLK21-E, Controller Link Support Software Operation Manual	Installation and operating procedures for the Controller Link Support Software. The Controller Link Support Software enables manually set data links and other procedures for a Controller Link Network.	W308
SYSMAC CS1W-CLK11/21, C200HW-CLK21, CVM1-CLK21 Controller Link Units Operation Manual	Installation, setup, and operating procedures for the Controller Link Units. Controller Link Units are used to connect C200HX/HG/HE and CV-series PCs to a Controller Link Network.	W309

Depending on the system, you may also need the SYSMAC or CV Support Software or a Programming Console. Refer to the body of this manual for details. Please read this manual and related manuals carefully and be sure you understand the information provided before attempting to install and operate a Controller Link Support Board.

**Section 1** outlines the features of the Controller Link Support Board, including the applications of the Controller Link Support Board and the differences between the Controller Link Support Board and the Controller Link Unit.

**Section 2** describes the methods for setting switches on the Controller Link Support Board, installing the Support Board in a computer, and wiring the Controller Link Network.

**Section 3** describes the procedure for installing the software necessary for using a Controller Link Support Board.

**Section 4** describes how to create applications (user programs) that control the Controller Link Support Board.

**Section 5** gives details on the C-language library commands and driver calls used by the Controller Link Support Board.

**Section 6** describes how to use data links in a Controller Link Network.

**Section 7** explains how to use the message service provided by a Controller Link Support Board.

**Section 8** describes the method used to connect multiple networks through CV-series PCs and CS1-series PCs.

**Section 9** provides details on Controller Link Network communications. Refer to this section for network communications that require accurate communications timing.

**Section 10** provides information on troubleshooting errors that occur during Controller Link Support Board operation, as well as daily inspection, cleaning, and other maintenance procedures.

**Appendix** provides a list of standard OMRON products related to Controller Link Networks.

 **WARNING** Failure to read and understand the information provided in this manual may result in personal injury or death, damage to the product, or product failure. Please read each section in its entirety and be sure you understand the information provided in the section and related sections before attempting any of the procedures or operations given.

# PRECAUTIONS

This section provides general precautions for using the Controller Link Support Board and related devices.

**The information contained in this section is important for the safe and reliable application of the Controller Link Support Board. You must read this section and understand the information contained before attempting to set up or operate a Controller Link Support Board.**

- 1 Intended Audience .....
- 2 General Precautions .....
- 3 Safety Precautions .....
- 4 Operating Environment Precautions .....
- 5 Application Precautions .....

## 1 Intended Audience

This manual is intended for the following personnel, who must also have knowledge of electrical systems (an electrical engineer or the equivalent).

- Personnel in charge of installing FA systems.
- Personnel in charge of designing FA systems.
- Personnel in charge of managing FA systems and facilities.

## 2 General Precautions

The user must operate the product according to the performance specifications described in the operation manuals.

Before using the product under conditions which are not described in the manual or applying the product to nuclear control systems, railroad systems, aviation systems, vehicles, combustion systems, medical equipment, amusement machines, safety equipment, and other systems, machines, and equipment that may have a serious influence on lives and property if used improperly, consult your OMRON representative.

Make sure that the ratings and performance characteristics of the product are sufficient for the systems, machines, and equipment, and be sure to provide the systems, machines, and equipment with double safety mechanisms.

This manual provides information for programming and operating the Controller Link Support Board and related devices. Be sure to read this manual before attempting to use the software and keep this manual close at hand for reference during operation.

 **WARNING** It is extremely important that a Controller Link Support Board and all related devices be used for the specified purpose and under the specified conditions, especially in applications that can directly or indirectly affect human life. You must consult with your OMRON representative before applying a Controller Link Support Board to the above mentioned applications.

## 3 Safety Precautions

 **WARNING** Never attempt to disassemble any Controller Link Support Board while power is being supplied. Doing so may result in serious electrical shock or electrocution.

 **WARNING** Never touch any of the terminals while power is being supplied. Doing so may result in serious electrical shock or electrocution.

 **Caution** Tighten the connector screws for the backup power supply to the torque specified in this manual. The loose screws may result in burning or malfunction.

## 4 Operating Environment Precautions

Do not operate the control system in the following places.

- Where the Controller Link Support Board is exposed to direct sunlight.
- Where the ambient temperature is below 5°C or over 45°C.
- Where the Controller Link Support Board may be affected by condensation due to radical temperature changes.
- Where the ambient humidity is below 8% or over 80%.



- Where there is any corrosive or inflammable gas.
- Where there is excessive dust, saline air, or metal powder.
- Where the Controller Link Support Board is affected by vibration or shock.
- Where any water, oil, or chemical may splash on the Controller Link Support Board.

 **Caution** The operating environment of the Controller Link Support Board or the computer can have a large effect on the longevity and reliability of the system. Improper operating environments can lead to malfunction, failure, and other unforeseeable problems with the Controller Link Support Board or the computer. Be sure that the operating environment is within the specified conditions at installation and remains within the specified conditions during the life of the system.

## 5 Application Precautions

Observe the following precautions when using the Controller Link Support Board or the computer into which it is installed.

 **WARNING** Failure to abide by the following precautions could lead to serious or possibly fatal injury. Always heed these precautions.

- Always ground the system to 100  $\Omega$  or less when installing the system to protect against electrical shock.
- Always turn off the power of the computer before attempting any of the following. Performing any of the following with the power supply turned on may lead to electrical shock:
  - Installing or removing the Support Board.
  - Assembling the Units.
  - Setting DIP switches or short-circuiting pins.
  - Connecting or disconnecting any cables or connectors.

 **Caution** Failure to abide by the following precautions could lead to faulty operation of the computer or the system or could damage the Controller Link Support Board or related devices. Always heed these precautions.

- Fail-safe measures must be taken by the customer to ensure safety in the event of incorrect, missing, or abnormal signals caused by broken signal lines, momentary power interruptions, or other causes.
- Always use the power supply voltage specified in the operation manuals. An incorrect voltage may result in malfunction or burning.
- Take appropriate measures to ensure that the specified power with the rated voltage and frequency is supplied. Be particularly careful in places where the power supply is unstable. An incorrect power supply may result in malfunction.
- Install external breakers and take other safety measures against short-circuiting in external wiring. Insufficient safety measures against short-circuiting may result in burning.
- Disconnect the functional ground terminal when performing withstand voltage tests. Not disconnecting the functional ground terminal may result in burning.
- Do not attempt to take the Boards apart, to repair the Boards, or to modify the Boards in any way.
- Be sure that all the mounting screws, terminal screws, and cable connector screws are tightened to the torque specified in this manual. Incorrect tightening torque may result in malfunction.

- Use crimp terminals for wiring. Do not connect bare stranded wires directly to terminals. Connection of bare stranded wires may result in burning.
- Double-check all the wiring before turning ON the power supply. Incorrect wiring may result in burning.
- Wire correctly.
- Double-check all the connectors before mounting the Board.
- Be sure that the communications cable connectors and other items with locking devices are properly locked into place. Improper locking may result in malfunction.
- Use a special packing box when transporting the Board. Handle the product carefully so that no excessive vibration or impact is applied to the product during transportation.
- Check the user program for proper execution before actually running it on the Unit. Not checking the program may result in an unexpected operation.
- Observe the following precautions when wiring the communications cable or backup power supply cables.
  - Separate the cables from power lines or high-tension lines.
  - Do not bend the cables.
  - Do not pull on the cables.
  - Do not place heavy objects on top of the cables.
  - Route cables inside conduits.
- Before touching the Unit, be sure to first touch a grounded metallic object in order to discharge any static built-up. Not doing so may result in malfunction or damage.
- Do not touch the Board surfaces or parts.
- Install the Board according to instructions in the operation manuals. Improper installation may cause faulty operation.
- Provide proper shielding when installing in the following locations:
  - Locations subject to static electricity or other sources of noise.
  - Locations subject to strong electromagnetic fields.
  - Locations subject to possible exposure to radiation.
  - Locations near to power supply lines.

# SECTION 1

## Features

This section outlines the features of the Controller Link Support Board, including the applications of the Controller Link Support Board and the differences between the Controller Link Support Board and the Controller Link Unit.

1-1	Overview .....
1-1-1	What Is the Controller Link? .....
1-1-2	Features .....
1-1-3	What Is a Controller Link Support Board? .....
1-1-4	Support Board Access Modes .....
1-1-5	Support Board vs Unit .....
1-1-6	Outline of Features .....
1-2	Specifications and Configurations .....
1-2-1	System Configuration .....
1-2-2	Communications Specifications .....
1-2-3	General Specifications .....
1-2-4	External Dimensions .....
1-2-5	Controller Link Support Board Configuration .....
1-2-6	Software Configuration .....
1-2-7	Supporting Computers, Operating Systems and Libraries .....
1-2-8	Memory and Disk Requirements .....
1-2-9	Controller Link Support Software .....
1-2-10	Communications Cables .....
1-2-11	Backup Power Supply (Optical System Only) .....
1-3	Basic Procedures .....
1-4	Applications Precautions .....

# 1-1 Overview

## 1-1-1 What Is the Controller Link?

The Controller Link is an FA network that can send and receive large data packets flexibly and easily among advanced OMRON Programmable Controllers (CS1-series, C200HX/HG/HE-series, and CV-series PCs) and IBM PC/AT or compatible computers.

The Controller Link supports data links that enable data sharing and a message service that enables sending and receiving data when required. Data link areas can be freely set to create a flexible data link system and effectively use data areas.

The network is connected using either shielded twisted-pair cable or optical fiber cable, and high-volume data transmissions at high speed enable construction of a wide range of networks, from low-level systems to high.

### Wired System (Twisted-pair Cable)

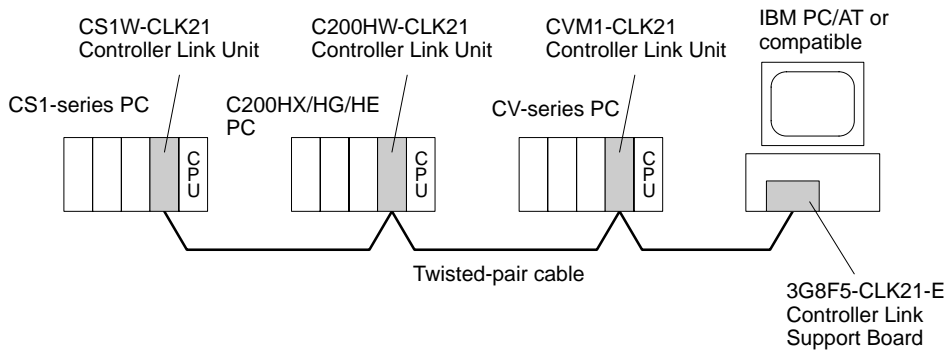

The functions of Controller Link are illustrated below.

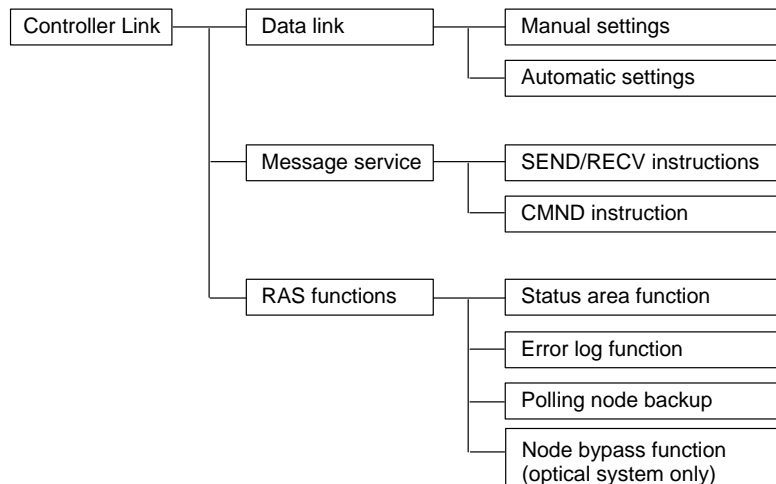

**Optical System (Optical Fiber Cable)**

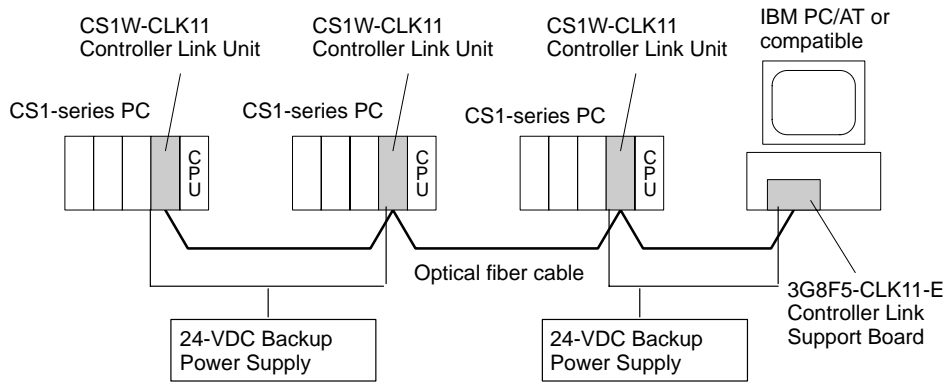

**Note** Connect the Backup Power Supply separately to each node.

**1-1-2 Features**

The Controller Link FA Network has the following features to meet the various requirements of FA sites.

**Data Links**

Flexible and efficient data links can be created for large capacities of data as listed below.

Item	Specifications
Number of send words per node	1,000 words max.
Number of send and receive words per node	Controller Link Support Board: 32,000 words max. Controller Link Unit for CS1 Series: 12,000 words max. Controller Link Unit For C200HX/HG/HE or CV Series: 8,000 words max.

Data links can be automatic set, or they can be set by the user to freely change the sizes of the data areas used. A data link can also receive only part of the data sent from another node. This function enables users to receive only the required data, thereby increasing data link efficiency.

**Message Service**

The message service can send and receive up to 2,012 bytes of data (including the FINS header), allowing high volumes of data to be sent and received without having to split it up.

**Twisted-pair Cable or Optical Fiber Cable Connection**

The Controller Link Units can be connected to the network using either shielded twisted-pair cables or optical fiber cables. Select the system that suits the application.

**Features of Twisted-pair Cable**

Twisted-pair cable is easy to connect and maintain. The cable can be processed much more easily than coaxial or optical cable, thereby reducing the cost of tools and assembly time.

Connections are made to a terminal block on the Controller Link Unit and to a special connector on the Controller Link Support Board for easy system assembly and modification.

The network is equipped with the required terminating resistance built into the Units allowing the terminating resistance to be easily set at both ends of the network using a simple switch.

**Features of Optical Fiber Cable**

Optical Fiber Cable has superior noise resistance, so this system can provide highly reliable communications even in very noisy conditions.

The communications distance can be up to 20 km in total (1 km max. between nodes), which allows long-distance or large-scale networks.

Once the Optical Fiber Cable has been fitted with special connectors, the cables can be easily connected or disconnected.

**Communications between Different Models**

The following Controller Link Units are available for communications between different models. It must be noted, however, that the wired system and optical system cannot exist in one Controller Link Network.

**Wired System**

- Controller Link Unit for CS1-series Programmable Controllers
- Controller Link Units for C200HX/HG/HE Programmable Controllers
- Controller Link Units for CV-series Programmable Controllers
- Controller Link Support Board for IBM PC/AT or compatible computers

**Optical System**

- Controller Link Unit for CS1-series Programmable Controllers
- Controller Link Support Board for IBM PC/AT or compatible computers

**Flexible Inter-network Connections**

The Controller Link Network can be connected to another network (Ethernet, SYSMAC NET Link, SYSMAC LINK, or another Controller Link network) through a CS1-series or CV-series PC. By installing Ethernet, SYSMAC NET Link, or SYSMAC LINK Communications Units on the same CS1-series PC or CV-series PC, a message service can be created with nodes in the interconnected networks through that PC. Up to three network levels are possible.

**Improved Error Handling**

An error log enables quick handling of errors by recording the time the error occurred and error details. The current Controller Link Unit and Support Board status are also available, as are the data link and network status.

When an error occurs in the polling node that controls the Controller Link Network, another node automatically becomes the polling node. This prevents an error at a single node from influencing other nodes on the network, achieving a highly reliable system.

With the Optical Controller Link Network, data communications can be continued even when a node or its power supply fails. The disabled node (PC or IBM PC/AT or compatible computer) is bypassed by the network. This bypass function prevents the network from crashing because of a single node failure or power interruption. A backup power supply must be provided to each node (Controller Link Unit or Support Board) to take advantage of the node bypass function.

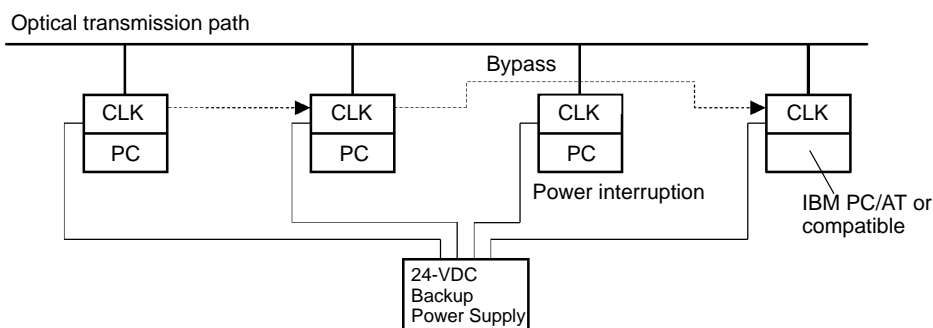

### 1-1-3 What Is a Controller Link Support Board?

A Controller Link Support Board is used to provide a direct connection to an IBM PC/AT or compatible computer on a Controller Link Network. A Controller Link Support Board supports data links, the message service, and RAS functions in the same way as a Controller Link Unit.

The Controller Link Support Board is supported by DOS. The Support Board is mounted in an expansion slot of an IBM PC/AT or compatible. The following Support Boards are available.

#### Wired System

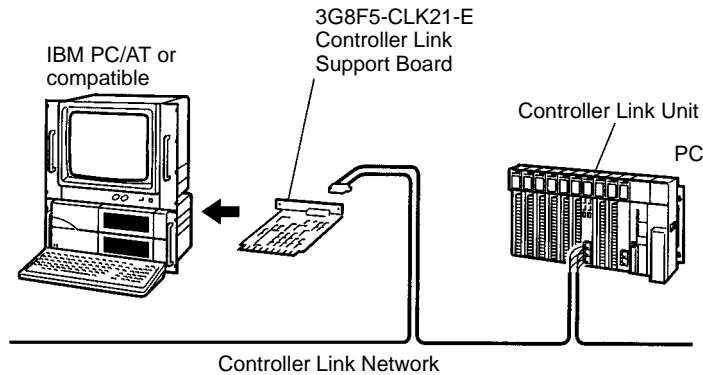

#### Optical System

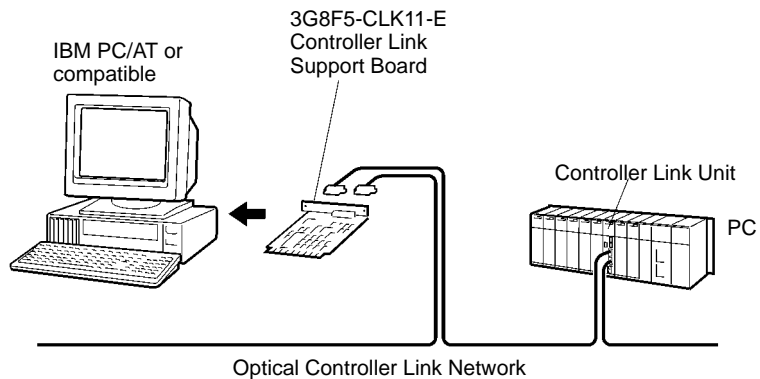

### 1-1-4 Support Board Access Modes

The access methods for the Controller Link Support Board are different from those of a Controller Link Unit. The following two methods are used to access the Controller Link Support Board.

#### Microsoft C library Functions from OMRON

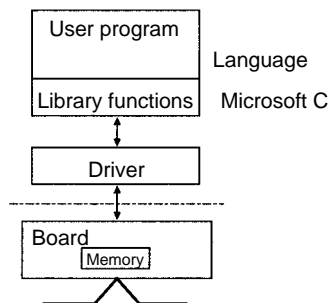

**Direct Driver Access**

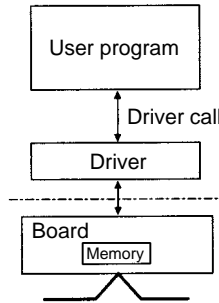

**1-1-5 Support Board vs Unit**

The following table shows a comparison between the Controller Link Support Board and a Controller Link Unit.

Item	Support Board	Unit
Communications cable connections	Special connector	Terminal block
Access method	Library functions or driver calls	From user program in CPU Unit
Network participation (participating/leaving network)	Library functions or driver calls	By turning the Unit ON and OFF
Data link cache	Either through a cache area created for the data link or by direct access to shared memory on the Support Board	Data automatically exchanged with I/O memory in CPU Unit.
Number of send and receive word in data link	32,000 words	8,000 words (for C200HX/HG/HE PCs) 12,000 words (for CV-series PCs)
Data link start word	Fixed	Variable
First data link status word	Fixed	Variable
Automatic data link settings	Can participate in automatically set data links, but cannot start or set the data links.	Can participate, start, or set links.
Message service	Message send and receive functions or driver calls in user program. The user program must provide any required responses.	SEND, RECV, and CMND instructions in user program in CPU Unit. Responses are automatically sent.



### 1-1-6 Outline of Features

#### Data Links

Data link data for each node is reflected in the shared memory area on the Board. When a data link cache is used, the data is edited according to the data link table and is stored in the data link cache area in memory. A data link cache area is not created unless a data link cache area is specified.

Users can access either the data link buffer in the shared memory or the data link cache area. The access method is selected by setting the Controller Link BIOS. Only one method can be used at a time.

The following figure illustrates reading and writing the data link cache area.

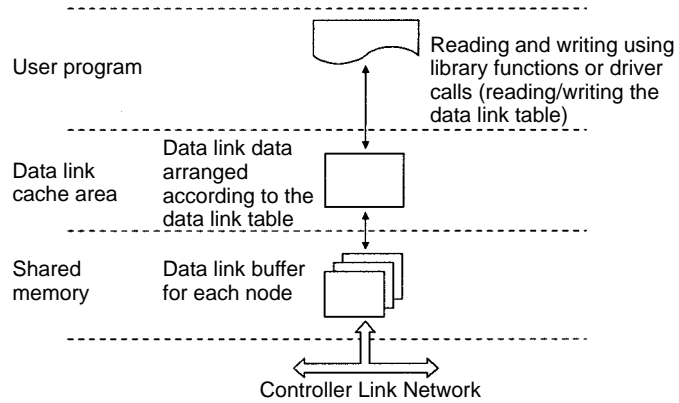

The following figure illustrates directly reading and writing data in the data link buffer in shared memory.

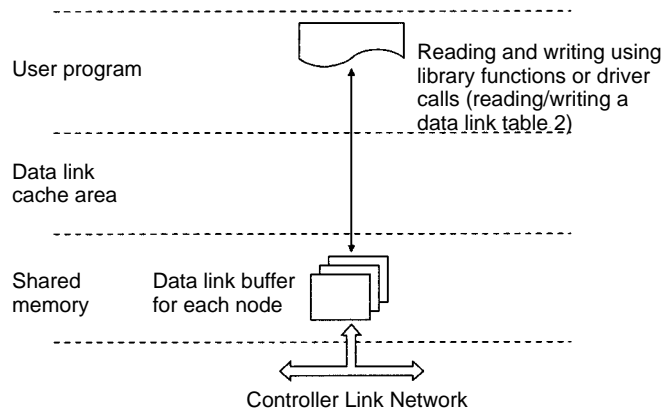

**Note** Check the available memory. The data link cache area occupies 64 Kbytes of conventional memory or XMS memory.

Data in area 1 and area 2 for each node is allocated consecutively in both the data link cache area and the shared memory data link buffer. When using data link cache areas, areas for each node are allocated in the order of node addresses set in the data link table.

When using data link cache areas, data for two or more consecutive nodes can be read or written. When using the data link buffer in shared memory (i.e., when not using data link cache areas), data in two or more nodes cannot be read or written concurrently.

The data link start word and data link status words are fixed.

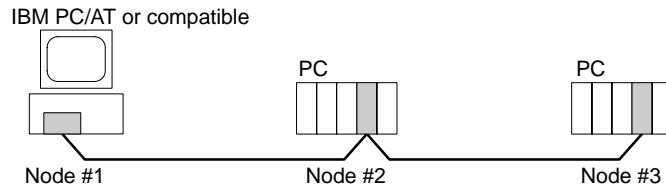

**Using the Data Link Cache Area**

Data for more than one node can be read or written at the same time.

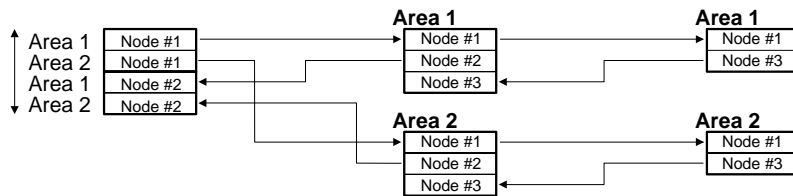

**Using the data link buffer in shared memory**

Data in only one node can be read or written at the same time.

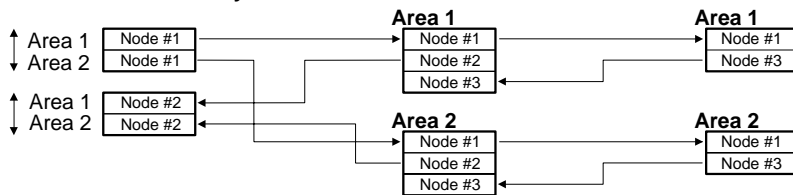

- Note**
1. Users can set whether data link cache areas are used when the Controller Link Support Software is installed (see page 44). The setting can be changed by modifying the CONFIG.SYS file after installation (see page 50).
  2. Use data link cache areas to create an application to read the data in the data link areas of two or more nodes at the same time (i.e., using the same function call or driver call). To do this, 64 Kbytes must be available in conventional memory or XMS memory.

The following table outlines the data link functionality for Controller Link Support Boards.

Items	Using a data link cache	Not using data link cache
<b>Data link data storage area</b>	Data link cache	Data link buffer in shared memory
<b>Data structure</b>		
<b>Unit of read/write data</b>	Continuous data from the specified address	Send data for each node (areas 1 and 2)
<b>Occupied memory</b>	64 Kbytes (conventional memory or XMS memory)	No memory used.
<b>Data contents</b>	Data created by editing the data in the data link buffer in shared memory according to the node addresses set in the data link table. <b>Note</b> The same data is returned if data is read before the refresh time for communications at a shorter interval.	Data for each node <b>Note</b> An error is returned as "Data Not Updated" if data is read before the refresh time for communications.

The following table shows the library functions and driver calls (function codes) that can be used to read and write data.

Items	Using a data link cache		Not using data link cache	
	Reading	Writing	Reading	Writing
<b>C functions</b>	clkread	clkwrite	clkread2	clkwrite2
<b>Driver call function codes (HEX)</b>	03	04	20	21

**Message Service**

A FINS command or FINS response can be sent or received for a specified node by executing a message send/receive library function or a driver call in the user program.

- When a FINS command is sent to read or write a memory area, the command corresponds to the SEND/RECV instruction for the Controller Link Unit.
- When other FINS commands are sent, the commands correspond to the CMND instruction for the Controller Link Unit.

Data transmission/reception to/from PC

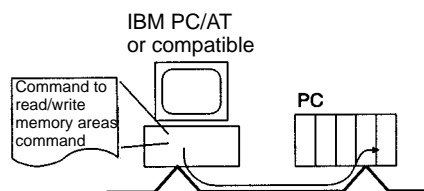

Any command transmission to PC

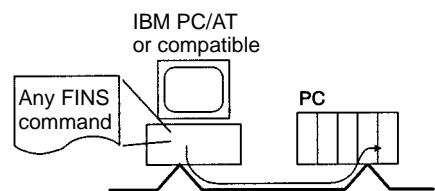

Item	Message transmissions	Message receptions	
		Without wait time	With wait time
C functions	clksend	clkrcv	clkrcvw
Driver call function codes (HEX)	01	02	

# 1-2 Specifications and Configurations

## 1-2-1 System Configuration

### Wired System

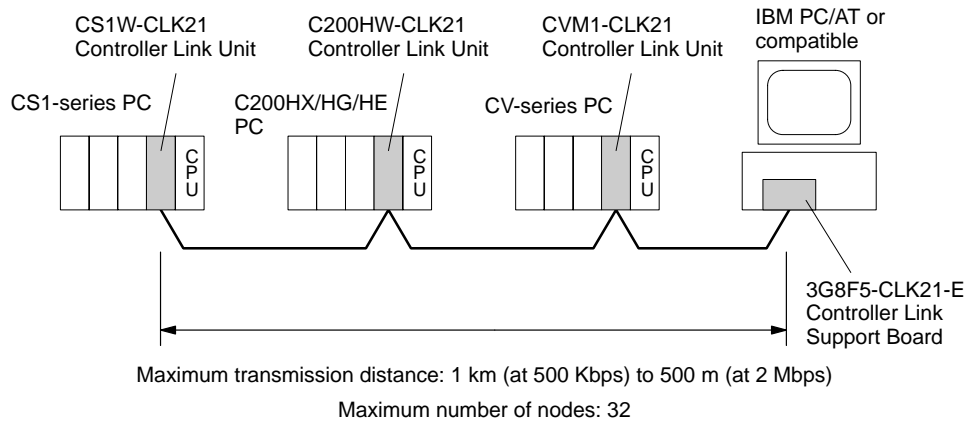

### Optical System

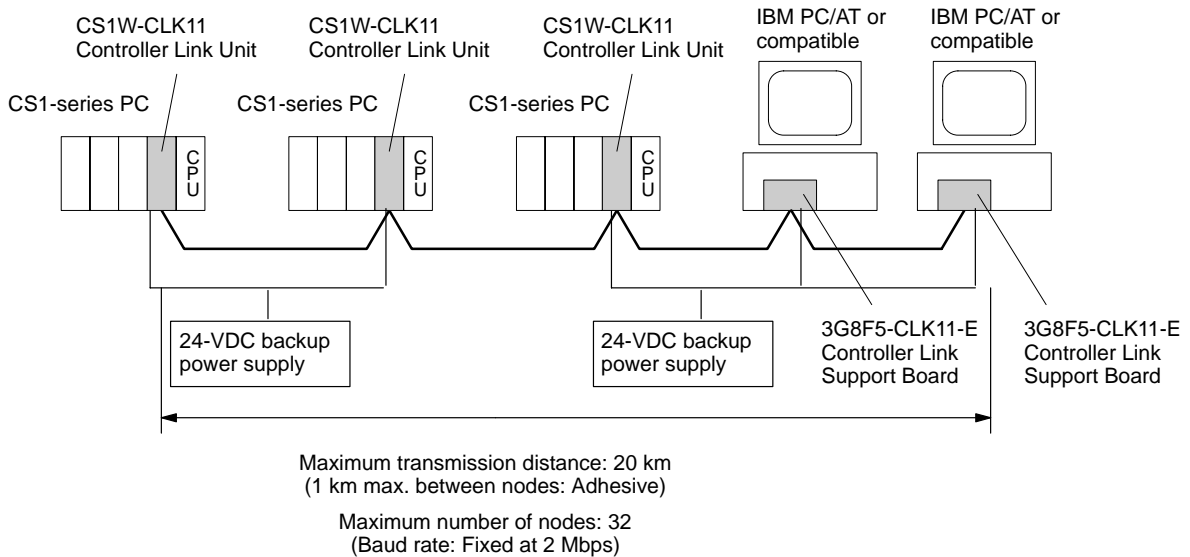

## 1-2-2 Communications Specifications

Items	Wired system	Optical system
Communications method	N:N token bus	
Code	Manchester code	
Modulation	Baseband code	
Synchronization	Flag synchronization (conforms to HDLC frames)	
Transmission path form	Multi-drop bus	Daisy-chain
Baud rate and maximum transmission distance	The maximum transmission distance varies with the baud rate as follows: 2 Mbps: 500 m 1 Mbps: 800 m 500 Kbps: 1 km	2 Mbps: 20 km (Crimp-cut: 800 m, adhesive: 1 km)  (The max. distance between Optical Units or Support Boards depends on the connector and cable preparation methods.)
Media	Specified shielded twisted-pair cable Number of signal lines: 2, shield line: 1	H-PCF cable (optical two-core cable)
Node connection method	PC: Connected to a terminal block IBM PC/AT or compatible: Connect with provided connector	Special full-lock connector (Half-lock connector can also be used)
Maximum number of nodes	32 nodes	
Communications functions	Data links and message service	
Number of data link words	Transmission area per node: 1,000 words (2,000 bytes) max. Data link area in one CS1-series PC (send/receive): 12,000 words (24,000 bytes) max. Data link area in one C200HX/HG/HE or CV-series PC (send/receive): 8,000 words (16,000 bytes) max. Data link area in one IBM PC/AT or compatible (send/receive): 32,000 words (64,000 bytes) max. Number of data link words in one network (send/receive): 32,000 words (64,000 bytes) max.	
Data link areas	IR, AR, LR, CIO, DM, and EM data areas	
Message length	2,012 bytes max. (including the header)	
RAS functions	Polling node backup function Self-diagnosis function (hardware checking at startup) Inter-node test and broadcast test (using the FINS command) Watchdog timer Error log function Node bypass function (available for the optical system only)	
Error control	Manchester code check CRC check ( $CCITT X^{16} + X^{12} + X^5 + 1$ )	

## 1-2-3 General Specifications

Items	Controller Link Support Board Specifications	
	Wired system: 3G8F5-CLK21-E	Optical system: 3G8F5-CLK11-E
External dimensions	106.7 x 163 mm (W x L)	
Weight	160 g	170 g (excluding securing bracket)
Current consumption	0.4 A max. at 5 VDC	0.5 A max. at 5 VDC
Ambient temperature	Operating: 5 to 45°C Storage: -20 to 60°C	
Humidity	8% to 80 % RH (without condensation)	
Atmosphere	Must be free of corrosive gases, etc.	

### 1-2-4 External Dimensions

#### Wired Model

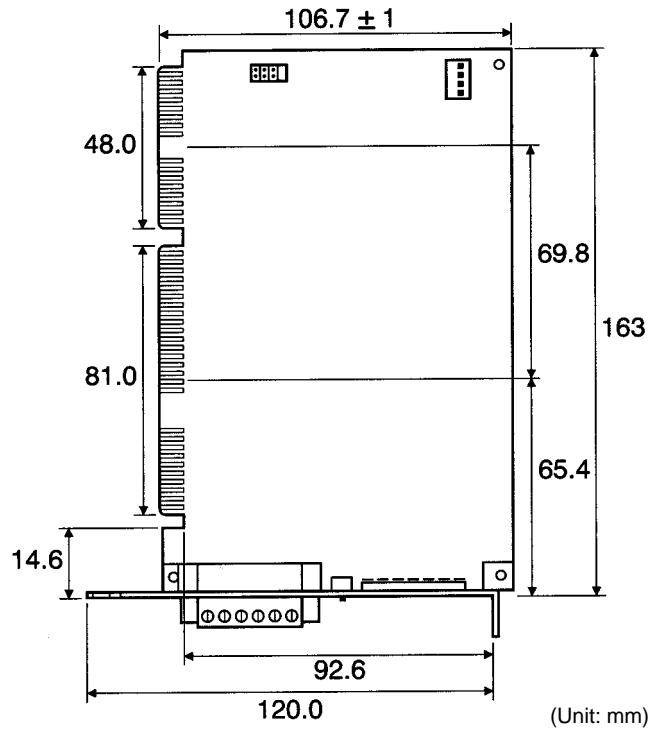

#### Optical Model

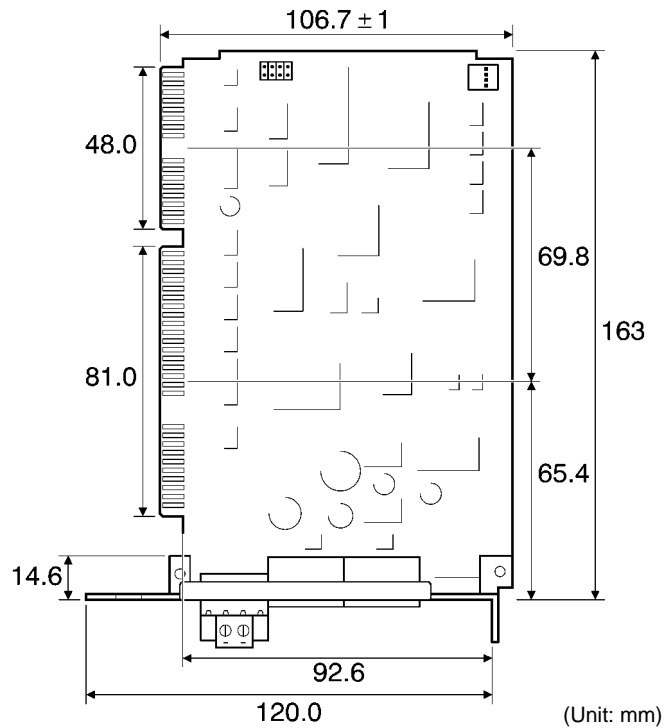

## 1-2-5 Controller Link Support Board Configuration

Model	Contents		
	Configuration	Documentation	Connectors
3G8F5-CLK21-E (Wired system)	One Board (3G8F5-CLK01, for IBM PC/AT or compatible)  One 3.5-inch floppy disk (1.44 Mbytes)	Controller Link Support Board Operation Manual (W307)  Controller Link Support Software Operation Manual (W308)	One communications connector
3G8F5-CLK11-E (Optical system)	One Board (3G8F5-CLK02, for IBM PC/AT or compatible)  One 3.5-inch floppy disk (1.44 Mbytes)	User registration card  Software license contract	One set of optical fiber cable securing brackets  One connector for the backup power supply

- Note**
1. The floppy disk also contains the Controller Link Support Software.
  2. The DOS operating system for an IBM PC/AT or compatible computer is not provided with the Support Board. The operation system must be acquired separately.

## 1-2-6 Software Configuration

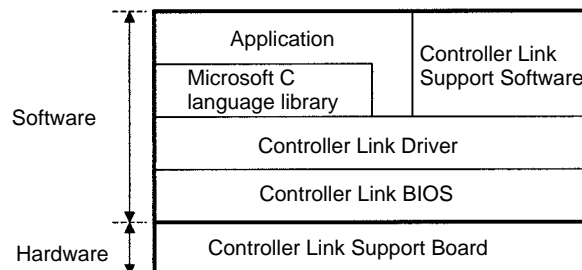

## 1-2-7 Supporting Computers, Operating Systems and Libraries

Controller Link Support Board	Supporting computer	Supporting operating system	Supporting language	Library name
3G8F5-CLK21-E (Wired system)	IBM PC/AT or compatible	IBM PC DOS Ver. 7.0	Microsoft C Ver 7.0A (large model)	CLKMSC.LIB
3G8F5-CLK11-E (Optical system)	CPU i386 or higher ISA bus	MS DOS Ver. 6.2		

- Note**
1. Operation of the Controller Link BIOS, Driver, and Library can be guaranteed only under the computer and operating system specified above. Please use the specified computer and operating system.
  2. The Controller Link BIOS, Driver, and Library cannot be used under Windows 3.1, Windows 95, or Windows NT. (It cannot be used from a DOS window either.)

### 1-2-8 Memory and Disk Requirements

**Hard Disk**

You must have at least 2 Mbytes of available space on your hard disk.

**Computer Memory**

Item		Required free area
Memory required for the Controller Link Driver		Main memory (conventional): 2.5 Kbytes + number of send/receive buffers x 2 Kbytes min.
Memory required for Controller Link BIOS	Not using data link cache	Main memory (conventional): 15 Kbytes min.
	Using standard memory cache	Main memory (conventional): 79 Kbytes min.
	Using XMS memory cache	Main memory (conventional): 15 Kbytes min. XMS memory: 64 Kbytes min.
Memory required for Controller Link Support Software		Main memory (conventional): 400 Kbytes min.

- Note**
1. When running the Controller Link Support Software with the Controller Link Driver and BIOS, set the number of buffers for the driver and BIOS data link cache area taking into account the amount of available memory the main memory.
  2. Set the number of buffers for the driver and BIOS data link cache area at installation or through the options for the Controller Link Driver and BIOS in CONFIG.SYS.

### 1-2-9 Controller Link Support Software

Settings and data monitoring are performed for the Controller Link Support Board using the Controller Link Support Software. Available operations include creating data link tables, monitoring data link status, reading error logs, and setting routine tables.

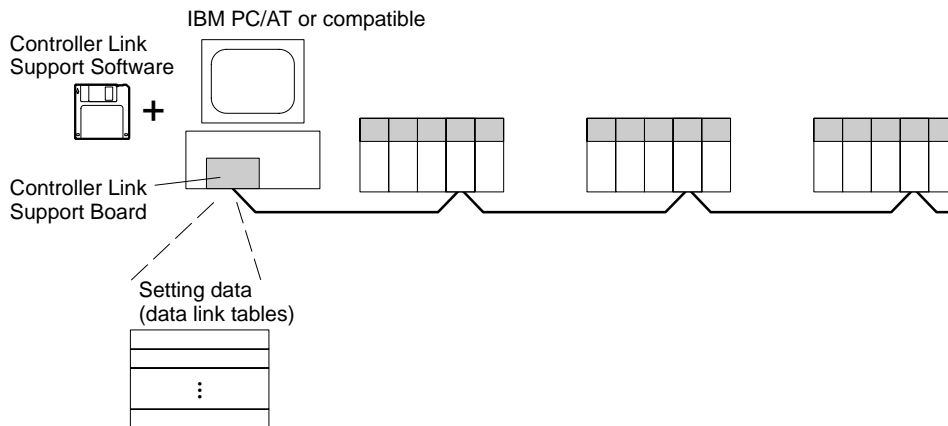

Controller Link Support Software can also be used for both Controller Link Units and the Controller Link Support Board.

Use the 3G8F5-CLK11 Controller Link Support Software to make settings for CS1-series Controller Link Units. For further details, refer to the *Controller Link Support Software Operation Manual (W308)*.

- Note** The settings in the Controller Link Support Board can be read from the Controller Link Support Software running on the computer connected to the PC. Refer to the *Controller Link Support Software Operation Manual (W308)* for detailed operating procedures.



### 1-2-10 Communications Cables

#### Wired System

The following shielded twisted-pair cable should be used for Controller Link Network connections.

Model	Manufacturer
Li2Y-FCY2 x 0.56 qmm	Kromberg & Schubert, Komtec Department
1 x 2 x AWG-20PE + Tr.CUSN + PVC	Draka Cables Industrial
#9207	Belden
ESVC 0.5 x 2 C	Bando Densen Co.

#### Optical System

The following devices are required for the Optical Controller Link Network. The cable and connectors are the same as those used for Optical SYSMAC LINK Networks.

#### Optical Fiber Cables

Use the following Optical Fiber Cables (Hard Plastic-clad Fiber: H-PCF).

Name	Specifications	Model	
H-PCF cables	Black	10 m	S3200-HCCB101
		50 m	S3200-HCCB501
		100 m	S3200-HCCB102
		500 m	S3200-HCCB502
		1,000 m	S3200-HCCB103
	Orange	10 m	S3200-HCCO101
		50 m	S3200-HCCO501
		100 m	S3200-HCCO102
		500 m	S3200-HCCO502
		1,000 m	S3200-HCCO103

**Note** The Optical Fiber Cable model numbers are as follows.

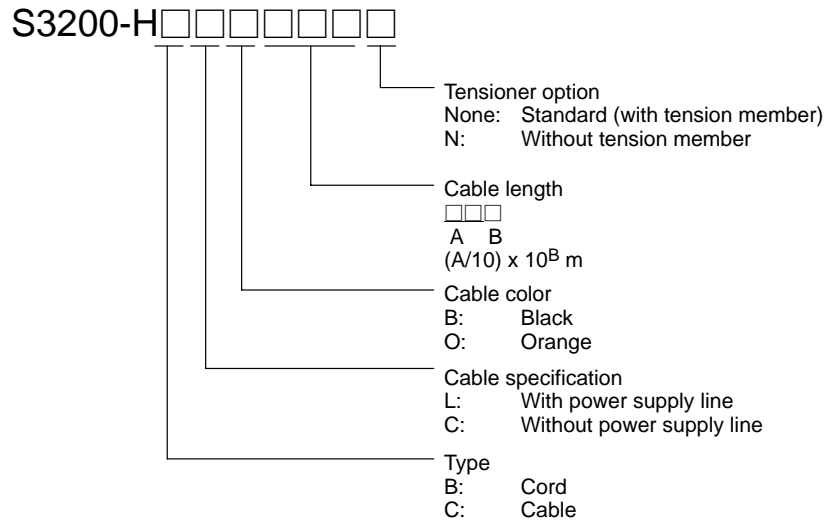

#### Optical Fiber Cable Connectors

Name	Model	Specifications
Connector	S3200-COCF2011	Use to connect a cable to a node. (Full-lock connector for crimp-cut cable.)
	S3200-COCF2511	Use to connect a cable to a node. (Half-lock connector for crimp-cut cable.)
Inline Adapter	S3200-COAT2000	Use to connect or extend cables. (Use one adapter for each connection.)

- Note**
1. Either full-lock or half-lock connectors can be used in a Controller Link Network, but we recommend full-lock connectors to prevent accidental disconnections during operation.
  2. The maximum distance between nodes is slightly shorter for connectors with crimp-cut cables compared to connectors assembled with adhesive. Also, the maximum distance is reduced when Inline Adapters are used to extend cables.

**Optical Fiber Cable with Connectors**

The following Optical Fiber Cables are available with Connectors already attached.

Specifications	Length	Model
Optical Fiber Cable Connectors: S3200-COCF2011 ↓ S3200-COCF2011	2 m	S3200-CN201-20-20
	5 m	S3200-CN501-20-20
	10 m	S3200-CN102-20-20
	15 m	S3200-CN152-20-20
	20 m	S3200-CN202-20-20
	Over 20 m	S3200-CN-20-20 (Specify length (m) when ordering.)
Optical Fiber Cable Connectors: S3200-COCF2011 ↓ S3200-COCF2511	2 m	S3200-CN201-20-25
	5 m	S3200-CN501-20-25
	10 m	S3200-CN102-20-25
	15 m	S3200-CN152-20-25
	20 m	S3200-CN202-20-25
	Over 20 m	S3200-CN-20-25 (Specify length (m) when ordering.)
Optical Fiber Cable Connectors: S3200-COCF2511 ↓ S3200-COCF2511	2 m	S3200-CN201-25-25
	5 m	S3200-CN501-25-25
	10 m	S3200-CN102-25-25
	15 m	S3200-CN152-25-25
	20 m	S3200-CN202-25-25
	Over 20 m	S3200-CN-25-25 (Specify length (m) when ordering.)

- Note**
1. The cables listed above are black and have power supply lines and tension members, although the power supply lines and tension members aren't used in the Controller Link Network.
  2. All of the cables listed above are attached to the connectors with adhesive.
  3. Special training is required to assemble Optical Fiber Cables and connectors with adhesive.

**Optical Fiber Cable Accessories**

Use the following accessories to assemble and test Optical Fiber Cables.

Name	Model	Specifications
Optical Fiber Assembly Tool	S3200-CAK1062	Crimp-cut tool for the S3200-COCF2011/2511 Connectors
Optical Power Tester	S3200-CAT2700	With S3200-CAT2702 Head Unit and adapter for the S3200-COCF2011/2511 Connectors
Master Fiber Set	S3200-CAT2001H	One meter cable for use with the S3200-CAT2702 Head Unit

This manual does not provide details on Optical Fiber Cable preparation. For details, refer to the instructions provided with the S3200-CAK1062 Assembly Tool.

### 1-2-11 Backup Power Supply (Optical System Only)

The Optical Controller Link's node bypass function can be used if each Controller Link Unit and Support Board is connected to a backup power supply. The node bypass function prevents the entire network from shutting down if the power supply to a single PC or personal computer is interrupted.

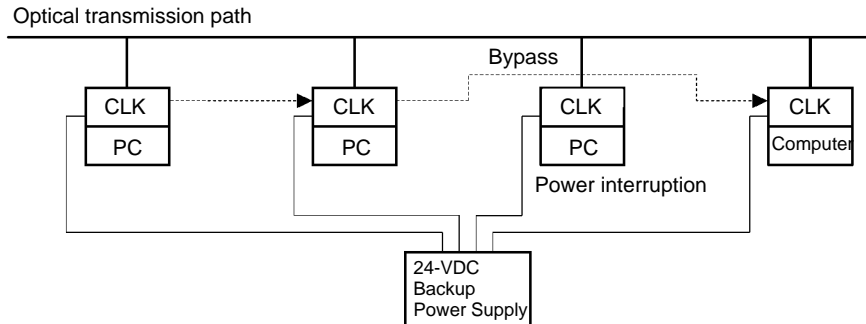

#### Backup Power Supply Specifications

The following table shows the input specifications required for backup power supplies to Controller Link Units and Support Boards. Be sure that the backup power supply being used meets these specifications. (We recommend OMRON S82K-series Power Supplies.)

Item	Specification
Voltage	24 VDC
Allowed voltage fluctuation	20.4 to 26.4 VDC (24 VDC -15%/+10%)
Current consumption	200 mA max. at 24 VDC (per node)
Inrush current	2.5 A max. (with a 24-VDC startup time of 5 ms)

When a single power supply is connected to several nodes or is some distance away from the node, make sure that the voltage at the node itself meets the specifications in the table above. There will be some voltage drop in the power supply wiring.

The power provided from the backup power supply will be used first if a backup power supply is connected. Be sure to consider the following points when designing the network.

- 1, 2, 3... 1. Turn on the PC or computer power supply after turning ON the backup power supply.
2. If the backup power supply goes ON or OFF, any data being transmitted at that moment will be corrupted.
3. Do not use the same power source to supply the backup power supply and the PC/Computer. The node bypass function will not operate if the backup power supply and the PC/Computer are both OFF.
4. Use a dedicated power supply for the backup power supply. Do not share a power supply being used for I/O, motors, or control systems.
5. Use a backup power supply that is double-insulated or one with reinforced insulation.

Always maintain a power supply voltage within specifications.

## 1-3 Basic Procedures

#### Initial Procedure

- 1, 2, 3... 1. Set the Board switches.
  - Memory address
  - Interrupt level

- Terminating resistance

**Note** Refer to *2-1-2 Setting Switches*.

2. Install the Board into the computer.

**Note** Refer to *2-1-3 Installing the Controller Link Support Board*.

3. Wire and connect the cables.

**Note** Refer to *2-2 Connecting Wired-system Cables* for wired systems and *2-3 Connecting Optical-system Cables* for optical systems.

4. Install the software.

- Copy the files.
- Set CONFIG.SYS to configure Controller Link BIOS and Driver.

**Note** Refer to *Section 3 Software Installation*.

5. Perform the data link and/or message service procedure.

#### Data Link Procedure

- 1, 2, 3...** 1. Create a data link table using the Controller Link Support Software and transfer the data to the Board.

**Note** When the data link tables and routing tables are transferred to the Controller Link Support Board, they are saved in the backup memory (EEPROM) on the Board. It is not necessary to set the data again when the power is turned off and on.

2. Open the Controller Link Driver and add the Board to the network.

3. Start data links.

**Note** The data links can also be started from the computer with the Controller Link Support Board by issuing the data link activation command of the message service.

4. Read and write data in the data link area (\*) by using library functions or driver calls.

5. Close the Controller Link Driver and leave the network.

#### Message Service Procedure

- 1, 2, 3...** 1. Create routing tables using the Controller Link Support Software and transfer the tables to the Board. (see note)

**Note** When the data link tables and routing tables are transferred to the Controller Link Support Board, they are save in the backup memory (EEPROM) on the Board. It is not necessary to set the data again when the power is turned off and on.

2. Open the Controller Link Driver and add the Board to the network.

3. Send and receive messages (data) using library functions or driver calls.

4. Close the Controller Link Driver and leave the network.

## 1-4 Applications Precautions

### Terminating Resistance Switch (Wired Systems Only)

Turn ON the terminating resistance switch only for the nodes at both ends of a wired Controller Link Network and turn OFF the switch for all other nodes.

**Note** Refer to *2-1 Installing the Support Board*.

### Cables

Turn OFF the power of all the nodes on the network before connecting or disconnecting a cable.

**Note** Refer to *2-2 Wiring*.

Use the specified cable only.

**Note** Refer to *1-2 Specifications and Configurations*.

### Baud Rates (Wired Systems Only)

In a wired Controller Link Network, set the same baud rate for all nodes on the same network.

**Note** Refer to *3-2 Installation Method*.

### Routing Tables

When a CV-series PC is connected to the network, set routing tables at all the nodes.

**Note** Routing tables are not required if all the CV-series CPU Units in the Controller Link Network have been manufactured on or after May 1996. The manufacturing date can be determined from the four-digit lot number on the side of the CPU Unit.

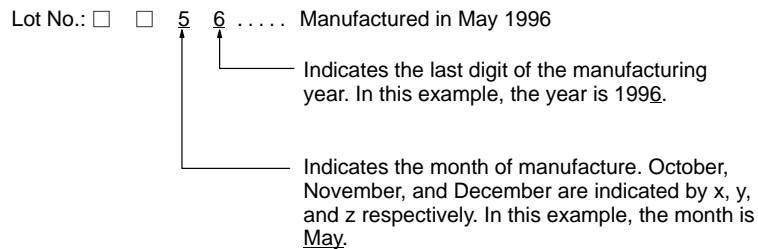

Set routing tables at all the nodes in all the networks when multiple networks are connected by a CV-series PC.

**Note** Refer to *Section 8 Network Interconnections*.

When a routing table is transferred (written) to a PC, all CPU Bus and Communications Units are reset. The routing tables must not be transferred to a PC while the system is running.

### Data Links

When using a manually set data link, delete the data link tables from all nodes not participating in the data link.

The polling node must not be restarted or reset during data link operation.

If the Controller Link Support Board is the polling node and data links are operating on the network, do not open the Board (clkopen) for three seconds after closing the Board (clkclos).

If the Controller Link Support Board is the polling node and data links are operating on the network, do not add the Board to the network for three seconds after leaving the network (clcmd or driver call function code: 07 HEX).

### Others Precautions

The Controller Link Support Board can be used only with the specified operating systems.

**Note** Refer to *1-2 Specifications and Configurations*.

Set the memory area and interrupt level of a Controller Link Support Board so that they do not overlap with other resources.

**Note** Refer to *2-1 Installing the Support Board, 3-2 Installation Method*.

# SECTION 2

## Setting, Installing, and Wiring Boards

This section describes the methods for setting switches on the Controller Link Support Board, installing the Support Board in a computer, and wiring the Controller Link Network.

- 2-1 Installing the Support Board .....
- 2-1-1 Support Board Components .....
- 2-1-2 Setting Switches .....
- 2-1-3 Installing the Controller Link Support Board .....
- 2-2 Connecting Wired-system Cables .....
- 2-2-1 Communications Cable .....
- 2-2-2 Connecting Cables to Communications Connectors .....
- 2-2-3 Connecting the Connector to the Board .....
- 2-3 Connecting Optical-system Cables .....
- 2-3-1 Optical Fiber Cable Connections .....
- 2-3-2 Backup Power Supply Wiring .....
- 2-3-3 Connecting the Backup Power Supply .....
- 2-3-4 Installing Connectors .....

## 2-1 Installing the Support Board

This section describes the methods for setting and installing the Controller Link Support Board in an IBM PC/AT or compatible computer.

### 2-1-1 Support Board Components

This section describes the name and function of each component. This section also describes the indicators.

#### Wired Board

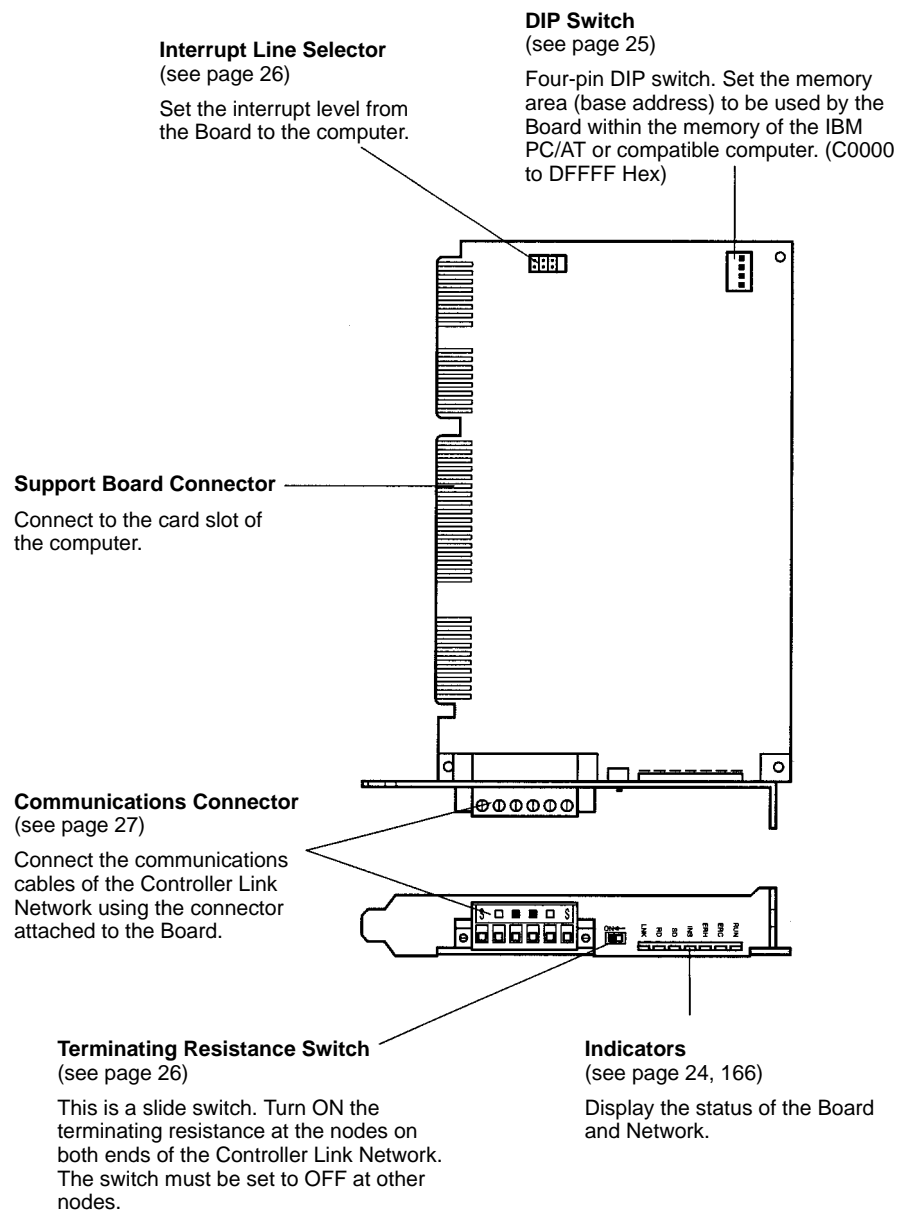

Optical Board

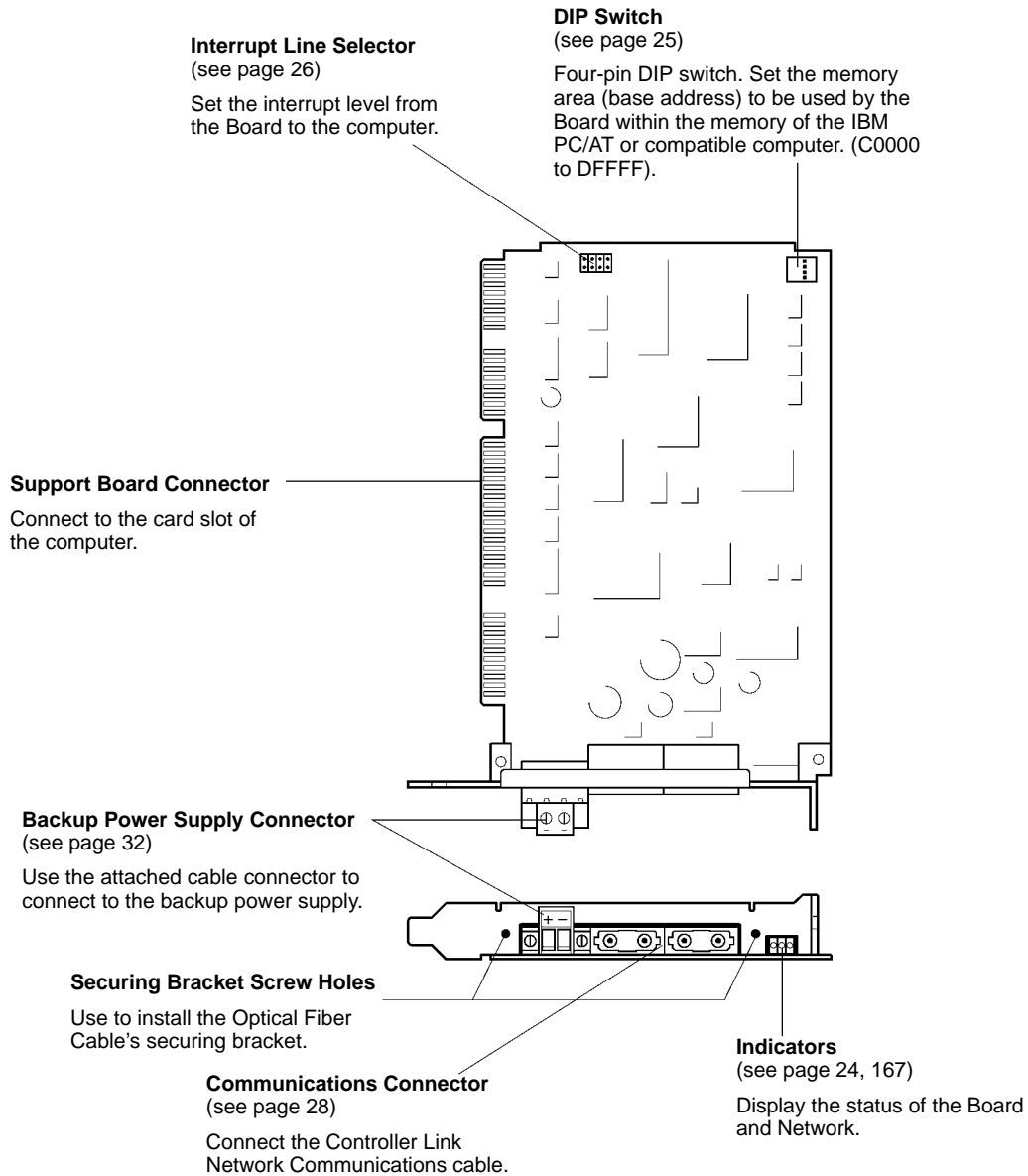



Indicators

**Wired Board**

Name		Color	Status	Meaning
RUN	Operating	Green	Lit	The Board is operating normally.
			Not lit	A Board operating error (watchdog timer error) occurred.
ERC	Communications error	Red	Lit	One of the following errors occurred: Communications error. Same node address used twice (i.e., address duplicate setting error). Hardware error.
			Not lit	Normal operation.
ERH	EEPROM error	Red	Lit	One of the following errors occurred. EEPROM error EEPROM data link table error EEPROM routing table error EEPROM network parameter error
			Not lit	No EEPROM error.
INS	Network participation	Yellow	Lit	Support Board is participating (inserted) in the network.
			Not lit	Support Board is not participating (inserted) in the network.
SD	Send	Yellow	Lit	Data transmission.
			Not lit	All other times.
RD	Receive	Yellow	Lit	Data reception.
			Not lit	All other times.
LNK	Data link	Yellow	Lit	Data links active.
			Flashing	Error in data link table setting.
			Not lit	Data link not participating or data link inactive.

**Optical Board**

Name		Color	Status	Meaning
RUN	Operating	Green	Lit	The Board is operating normally.
			Not lit	A Board operating error (watchdog timer error) occurred.
ERR	Error	Red	Lit	One of the following errors occurred: Communications error. Same node address used twice (i.e., address duplicate setting error). Hardware error. EEPROM error.
			Not lit	Normal operation.
INS	Network participation	Yellow	Lit	Support Board is participating (inserted) in the network.
			Not lit	Support Board is not participating (inserted) in the network.
LNK	Data link	Yellow	Lit	Data links active.
			Flashing	Error in data link table setting.
			Not lit	Not participating in data link or data link inactive.
P/S	Power Supply	Green	Lit	Backup power is being supplied.
			Not lit	Backup power is not being supplied.

## 2-1-2 Setting Switches

The following settings must be made on on a Controller Link Support Board.

Setting item	Setting section	Page
Memory address	Memory allocation switch	25
Interrupt level	Interrupt short pin	26
Terminating resistance (Wired Boards only)	Terminating resistance switch	26

- Note**
1. Always turn the computer OFF before changing switch or pin settings.
  2. The memory address and interrupt level must be set before the Board is installed in the computer.
  3. Set the baud rate (Wired Boards only), node address, and unit number as options in the CONFIG.SYS of Controller Link BIOS.

### Setting the Memory Area

Using the memory allocation switch (DIP switch), set the base address of the memory area to be used by the Controller Link Support Board within the memory of the computer. The area can be set within the following range providing the area does not overlap another resource currently used the computer.

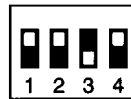

(This diagram shows the factory default setting.)

SW1	SW2	SW3	SW4	Base address	Memory used
ON	ON	ON	ON	C0000 Hex	C0000 to C1FFF Hex
OFF	ON	ON	ON	C2000 Hex	C2000 to C3FFF Hex
ON	OFF	ON	ON	C4000 Hex	C4000 to C5FFF Hex
OFF	OFF	ON	ON	C6000 Hex	C6000 to C7FFF Hex
ON	ON	OFF	ON	C8000 Hex*	C8000 to C9FFF Hex*
OFF	ON	OFF	ON	CA000 Hex	CA000 to CBFFF Hex
ON	OFF	OFF	ON	CC000 Hex	CC000 to CDFFF Hex
OFF	OFF	OFF	ON	CE000 Hex	CE000 to CFFFF Hex
ON	ON	ON	OFF	D0000 Hex	D0000 to D1FFF Hex
OFF	ON	ON	OFF	D2000 Hex	D2000 to D3FFF Hex
ON	OFF	ON	OFF	D4000 Hex	D4000 to D5FFF Hex
OFF	OFF	ON	OFF	D6000 Hex	D6000 to D7FFF Hex
ON	ON	OFF	OFF	D8000 Hex	D8000 to D9FFF Hex
OFF	ON	OFF	OFF	DA000 Hex	DA000 to DBFFF Hex
ON	OFF	OFF	OFF	DC000 Hex	DC000 to DDFFF Hex
OFF	OFF	OFF	OFF	DE000 Hex	DE000 to DFFFF Hex

\*Factory default setting.

- Note**
1. Set the memory area so that it does not overlap another resource on the computer.
  2. The base address is set to C8000 Hex by default.
  3. If the memory area overlaps another resource, the computer will not start normally.
  4. The memory area used by the Controller Link Support Board must not be set to Shadow RAM.

- When using EMM386.EXE, set the memory area used by the Controller Link Support Board to a prohibited address.

Parameter setting method: X = mmmm – nnnn  
 mmmm: Starting address (leftmost 4 digits)  
 nnnn: Ending address (rightmost 4 digits)

**Setting the Interrupt Level**

Set interrupt levels from the Controller Link Support Board to the computer using the short pin. The level can be set within the following range unless the setting is already being used by another resource on the computer.

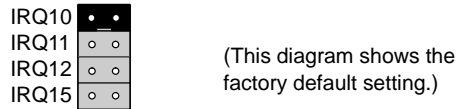

Setting	Interrupt level
10*	IRQ10*
11	IRQ11
12	IRQ12
15	IRQ15

\*Factory default setting.

Insert a short pin in the position corresponding to the interrupt level to be set. Insert the short pin completely.

- Note**
- Do not set an interrupt level already used by another resource on the computer.
  - The default interrupt level is IRQ10.

**Setting Terminating Resistance(Wired Board Only)**

Use the terminating resistance switch specify whether or not the built-in terminating resistance is used. The terminating resistance is required at the end of a wired network to absorb unnecessary signals and reduce noise. The Controller Link Support Board is equipped with built-in terminating resistance that can be used by turn ON a switch. Set the switch to ON at the nodes at both ends of a wired network to connect the terminating resistance. Set the switch to OFF to disconnect terminating resistance at all other nodes.



Setting	Terminating resistance
OFF*	Terminating resistance not connected.
ON	Terminating resistance connected.

\*Factory default setting.

- Note**
- This switch can be set after the Board is installed in the computer. Turn OFF the power of the computer before changing the setting.
  - The switch is set to OFF by default (terminating resistance disconnected).

**2-1-3 Installing the Controller Link Support Board**

After completing the settings, install the Controller Link Support Board in an extension slot of your IBM PC/AT or compatible computer.

**Installation Restrictions**

Only one Controller Link Support Board can be installed in each computer. Install the Controller Link Support Board in an ISA bus connector (a connector that fits the connector on the Board).

- Note**
1. Turn OFF the power of the computer and all the peripheral devices before installing or removing the Board.
  2. Utmost care is necessary when installing or removing the Board in order to prevent static electricity. Static electricity may damage the Board or computer.
  3. When installing or removing the Board, handle it with care so so you do not scratch the memory board or other parts of the computer.
  4. Do not directly touch the surface of the Board or its parts.
  5. The following procedure and diagrams are for a typical computer. Your computer may be different. Refer to the user documentation for your computer for specific details.

## 2-2 Connecting Wired-system Cables

This section describes the methods for wiring network communications cables to the Controller Link Unit.

### 2-2-1 Communications Cable

Wire the communications cable to connect identical signals.

- Note**
1. Use the cable specified for the communications cable.
  2. Keep communications cable separated from power lines or a high-tension lines to prevent influences from electronic noise.
  3. Ground the shield line of the communications cable at one end of the network. Do not ground the shield at both ends.
  4. Do not connect the shield cable of the communications cable to a ground that is also being used for power-system devices, such as inverters.
  5. Turn ON the terminating resistance switch at the nodes at both ends of the network to connect terminating resistance. Turn OFF the terminating resistance switch at all nodes.
  6. Do not run wiring outdoors. If outdoor wiring is necessary, take protection measures against lightning, such as underground wiring or wiring inside pipes.
  7. The minimum length of the communications cable between nodes is 1 m. Prepare the communications cables at a length of 1 m or more.
  8. Use the multidrop method for connecting nodes. Normal communications will not be possible with T branches.
  9. Terminals for the same signal on the connector are connected internally in the Controller Link Support Board.

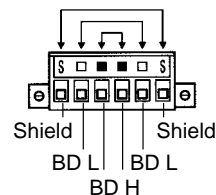

10. Although this section discusses wiring Controller Link Support Boards only, a Controller Link Unit could take the place of any Board and can be connected in the same fashion as a Board.
11. The ground wire connected to the connector of a Controller Link Support Board must be 2.5 mm<sup>2</sup> or less.

Connect all the shield lines of the communication cables and then ground the shield at one end of the network. The wiring method is shown below.

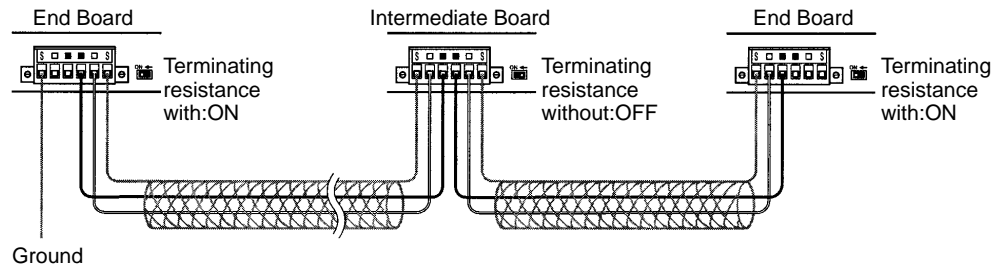

**Note** Since terminals of the same type are connected internally, they can be connected to either the right or left half of the end Boards.

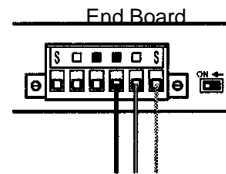

### 2-2-2 Connecting Cables to Communications Connectors

When connecting a communications cable to a Controller Link Support Board, connect the cable to the attached connector first and then attach to the connector on the Board. Connect the communications cable to the connector using the following procedure.

- 1, 2, 3...**
1. Peel back the cover of the cable for about 50 mm without scratching the mesh of the shield. Do not peel too much because it may cause a short-circuit.

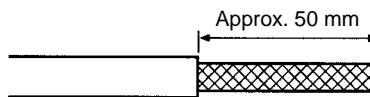

2. Twist the mesh of the shield to form a line on the end on which the shield is to be connected to a node.
3. Apply a heat-shrink tubing to the twisted shield line, leaving enough bare wire to attach the crimp terminal.

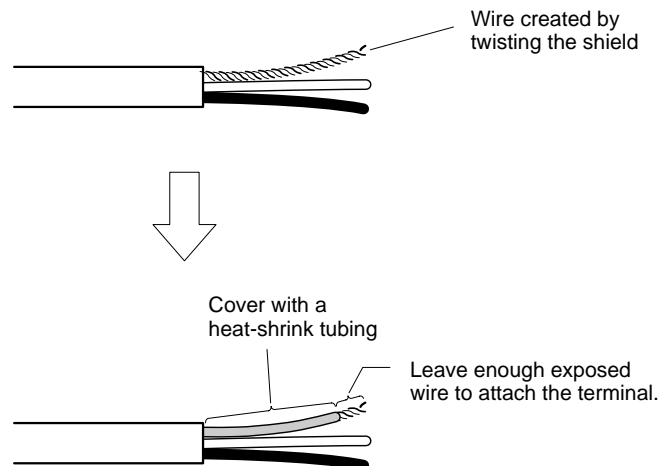

**Note** a) Turn OFF the power of the computer before connecting the communications cable or connecting/disconnecting a connector.

- b) Use the connector attached to a Controller Link Support Board.
- 4. Strip the insulation far enough to attach the crimp terminals and twist the wire strands tight.

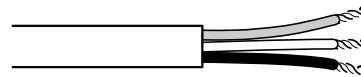

- 5. Apply electrical tape or heat-shrink tubing to the end of the cable cover that was peeled in step 1.

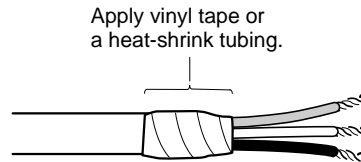

- 6. Attach the crimp terminals to the shield wire and signal wires. Apply electrical tape or heat-shrink tubing to the connections.

**Note** We recommend the Phoenix AI-series crimp terminals shown in the following diagram. The Phoenix Company's ZA3 crimping tool can be used to attach these terminals.

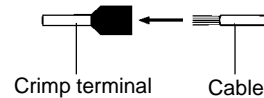

- 7. Carefully insert the signal line and shield line into each hole of the connector. Insert as marked on the connector. The following example shows connection to a Board in the middle of the Network.

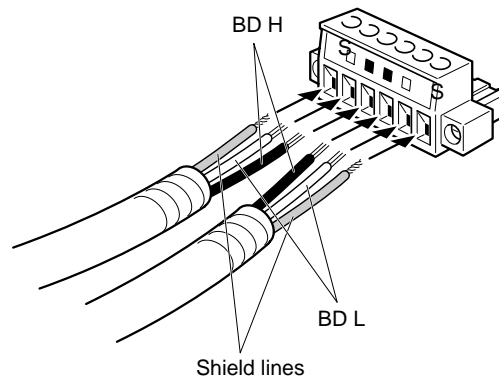

- Note** a) Loosen the screws in the connector enough to allow the terminal to pass before inserting the signal line. If the screw is not loosened, the signal line will go completely into the connector and you will not be able to secure the line.
- b) Attach crimp terminals to the wires. Never connect a bare power supply wire directly into the connector.
- c) Marks are provided on the connector for the signal lines. Connect the signal lines according to the marks. The marks correspond to signal lines as listed below.

Marking	Signal name	Line color
■	BD H (communication data high side)	Black
□	BD L (communication data low side)	White
S	SHLD (shield)	---

- d) The lines can be connected to either the right or left half of the connector at the node at either end of the network.
8. Firmly secure each signal line with the signal line screw on the connector. An ordinary flat-blade screwdriver with a tip that tapers at the end is not suitable because it cannot be inserted far enough. Use a small flat-blade screwdriver with a constant width. The appropriate tightening torque is 0.2 N-m.

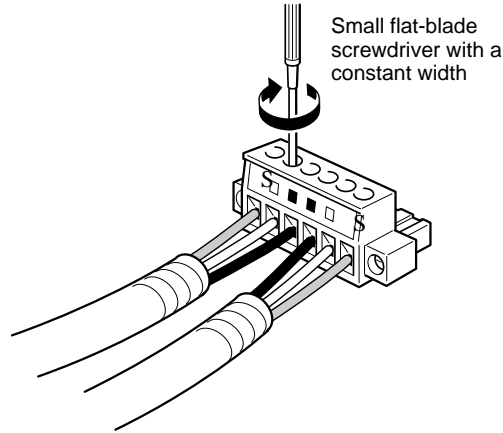

**Note** The following screwdriver is available from OMRON.  
Model XW4Z-00C

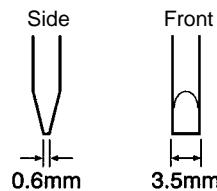

### 2-2-3 Connecting the Connector to the Board

Connect the connector on the communications cable to the connector on the Board using the following procedure.

- 1, 2, 3...** 1. Connect the connector on the communications cable to the connector on the Board as shown below.

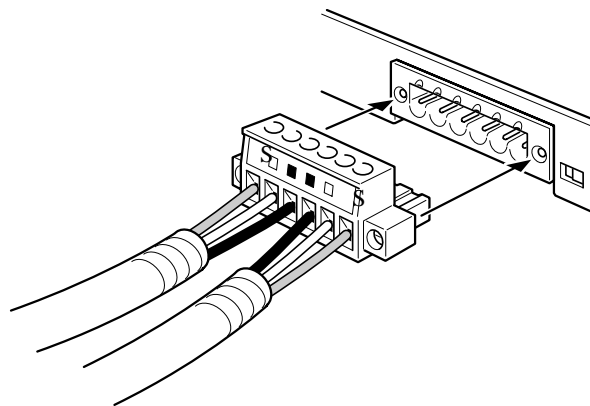

2. Secure the connector to the Board by tightening the screws on the connector. The appropriate tightening torque is 0.2 N-m.

- Note** 1. If the connector is disconnected, communications for the Board that was disconnected with other nodes in the network will be disabled and the network will be split into two at point of disconnection. Utmost care is necessary to prevent disconnection of a connector during communications.

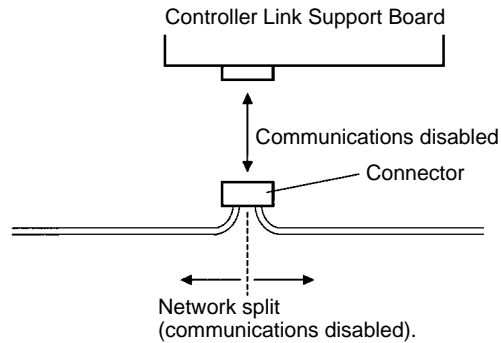

2. Do not pull on a communication cable.
3. When bending a communications cable, allow 60 mm or more for the bending radius (R).

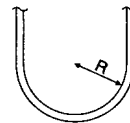

4. Do not place heavy objects on the communications cable.
5. Supply power only after checking the wiring thoroughly.

## 2-3 Connecting Optical-system Cables

### 2-3-1 Optical Fiber Cable Connections

All of the nodes in an Optical Controller Link Network are connected in a line (daisy-chain configuration) with H-PCF Optical Fiber Cable.

The nodes can be connected in any order, but be sure to begin at the with the rightmost connector (SL1) of the highest node in the network and connect to the leftmost connector (SL2) in the next lower node, as shown in the following diagram. Also be sure to cover the unused connectors on the highest and lowest nodes in the network with the provided Optical Connector Covers.

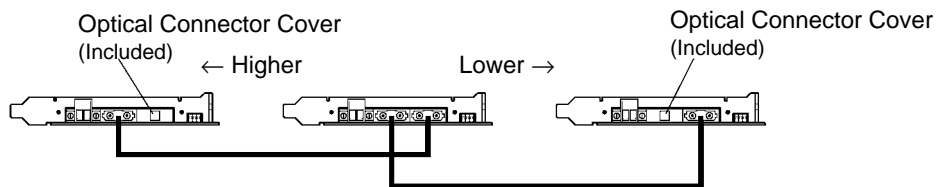

See 1-2-10 *Communications Cables* for details on available Optical Fiber Cables. See 2-3-4 *Installing Connectors* for details on connecting the Optical Fiber Cables to the Controller Link Board.

- Note**
1. Always use the specified Optical Fiber Cables.
  2. The maximum distance between nodes depends on the method used to attach the connector to the cable.

### 2-3-2 Backup Power Supply Wiring

Each node requires a backup power supply for the node bypass function. Several nodes can be connected to a single power supply or each node can be connected to an independent power supply. If several nodes are connected to a single power supply, be sure to wire each node separately as shown in the following diagram.



Be sure that the backup power supply is providing sufficient current and voltage at the Board's connector. See 1-2-11 Backup Power Supply (Optical System Only) for the backup power supply specifications.

Connect the backup power supply to the power supply terminals at the bottom of the Controller Link Support Board. See 2-3-3 Connecting the Backup Power Supply for details on connecting the power supply cable to these terminals.

- Note**
1. Do not use the same power source to supply the backup power supply and the computer. The node bypass function will not operate if the backup power supply and the computer are both OFF.
  2. Use a dedicated power supply for the backup power supply. Do not share a power supply being used for I/O, motors, or control systems.
  3. When two or more nodes are connected to a single power supply, wire each node separately as shown on the left in the following diagram.

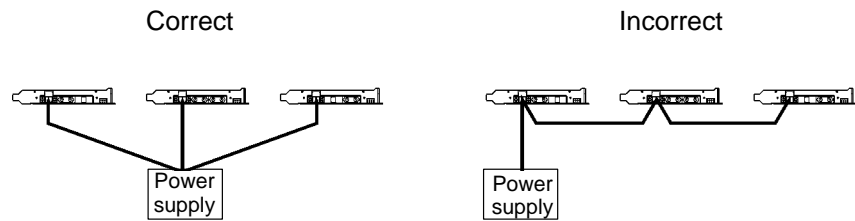

### 2-3-3 Connecting the Backup Power Supply

Observe the following precautions when connecting the backup power supply:

- Separate the backup power supply wires from other power lines and high-voltage lines to prevent noise.
- Attach the special crimp terminals to the power supply wires.
- Be sure not to reverse the power supply polarity.
- Tighten the power supply cable hold-down screws to 0.2 N • m.
- Do not pull on the power supply cable.
- Do not bend the power supply cable too sharply.
- Do not place any objects on top of the power supply cable.
- Verify that the connector is installed properly before using the power supply.
- Check the wiring configuration carefully before turning ON the power.

Connect the power supply cable to the cable connector and then secure it to the Board, as shown in the following diagram. Be sure that the power supply polarity is not reversed.

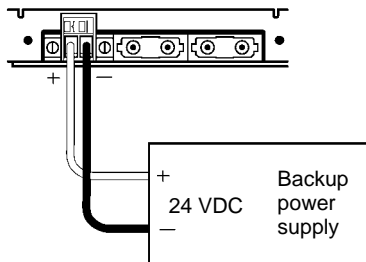

The connector for the backup power supply is the same as the communications connector for Wired Controller Link Support Boards. See 2-2-2 Connecting Cables to Communications Connectors for details on preparing the power supply wires and connecting them to the connector.

- Note** It is difficult to connect or disconnect the backup power supply connector after the Optical Fiber Cable's securing bracket has been installed. Insert the connector before installing the securing bracket.

### 2-3-4 Installing Connectors

A special connector is used to connect the Optical Fiber Cable to the Controller Link Support Board. Connect the nodes in order beginning with the highest node in the network and continuing on to lower nodes.

This manual does not provide details on Optical Fiber Cable preparation.

Observe the following precautions when connecting the Optical Fiber Cables.

- Always turn OFF the computer and backup power supply before connecting Optical Fiber Cables or the backup power supply connector.
- Special tools are required to attach Optical Fiber Cables to the connectors. The cable may disconnect from the connector if the proper tools and methods are not used during cable assembly.
- Insert the connectors completely and always check that the connectors are locked before starting operation.
- If a connector becomes disconnected, the node will be unable to communicate with other nodes in that part of the network. The network will be divided into two and communications with the remaining nodes will be unreliable.

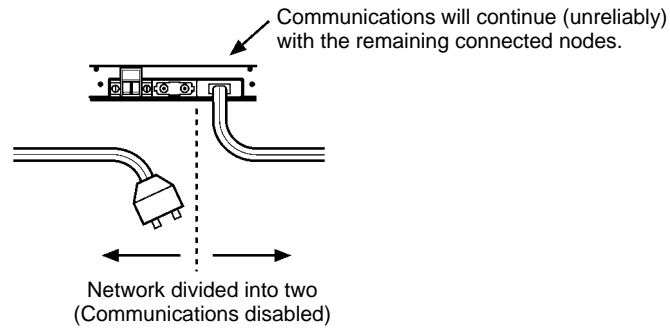

- Do not pull on the Optical Fiber Cable too forcefully. The maximum tension that can be applied to the cord is 10 kg (about 22 lbs) and the maximum tension that can be applied to the cable is 50 kg (about 110 lbs).

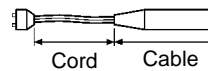

- Do not bend the cable too sharply. The minimum radius for bends is 10 cm.

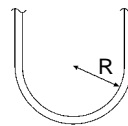

- To prevent the Optical Fiber Cable from being pulled too forcefully, always use the cable securing bracket and provide space behind the Board as shown in the following diagram. Do not exceed the maximum tension for the cord and cable:

Cord: 0 kg (Do not apply any tension.)

Cable: 5 kg (about 11 lbs)

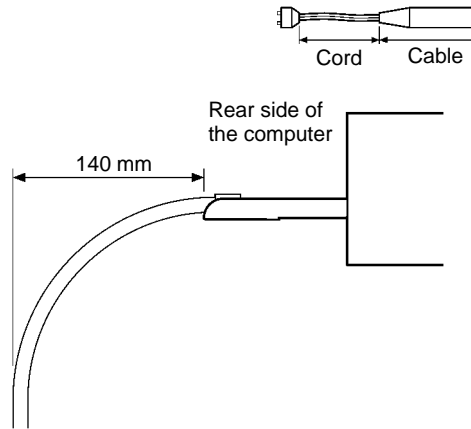

- Do not place objects on top of the Optical Fiber Cable. The maximum pressure that can be placed on the cord and cable is as follows:

Cord: 30 kg/10 cm

Cable: 50 kg/10 cm

- Inspect the connector before installing it.
- When connecting or disconnecting the Optical Fiber Cable, be sure to hold the connector firmly. (Do not pull on the cable itself.)

**Connection Procedure**

Use the following procedure to connect Optical Fiber Cables to a Board. It is difficult to connect the backup power supply connector after the Optical Fiber Cable's securing bracket has been installed, so insert the backup power supply connector first if the node bypass function is being used.

- 1, 2, 3...
- The Optical Fiber Cable's power supply line and tension member are not used, so they can be cut.
  - Open the clamps on the cable securing bracket. Simply pull up on the tabs protruding from the sides of the clamps.

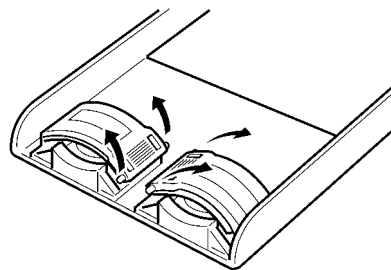

- The clamps in the securing bracket lock the cables in place, as shown in the following diagram. Be sure that the Optical Fiber Cable that connects to the right side of the Board is clamped on the right side and the Optical Fiber Cable that connects to the left side of the Board is clamped on the left side.

Adjust the cables so that the tip of the cable extends a little bit past the bracket's pattern, check the direction of the connectors, and close the clamps. Press firmly on the tip of the clamp so that it contacts the bottom part of the clamp.

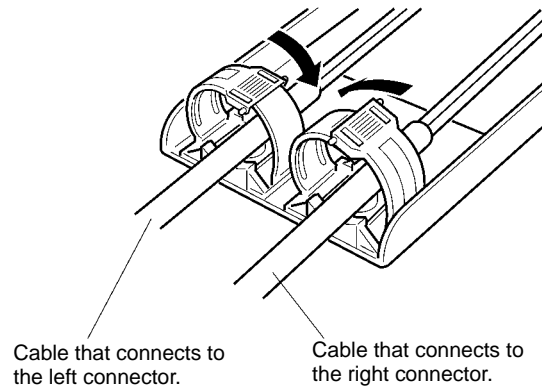

4. Install the securing bracket on the Board with the screws provided. Be sure not to pull the cable forcefully or bend it too sharply while installing the bracket.
5. Doublecheck the direction of the cables. The cable from the node higher in the network connects to the Board's right connector and the cable to the node lower in the network connects to the Board's left connector. Insert the cable's connectors fully into the Board's connectors.

# SECTION 3

## Software Installation

This section describes the procedure for installing the software necessary for using a Controller Link Support Board.

- 3-1 Preparations .....
  - 3-1-1 File Structure .....
  - 3-1-2 Backing Up the Installation Disk .....
- 3-2 Installation Method .....
  - 3-2-1 Using the Installer .....
  - 3-2-2 Installer Troubleshooting .....
  - 3-2-3 Driver Options in CONFIG.SYS .....
- 3-3 Confirming Normal Startup .....
  - 3-3-1 Controller Link BIOS .....
  - 3-3-2 Controller Link Driver .....
  - 3-3-3 Board Indicators .....

### 3-1 Preparations

#### 3-1-1 File Structure

The Controller Link Support Board files include the following:

File name	Contents
INSTALL.EXE	Installer
INSTALL.INF	Installation data file 1
DISK1	Installation data file 2
README.TXT	File configuration description file
CLK.CNF	CONFIG.SYS sample
CLKBIOS.SYS	Controller Link BIOS
CLKDRV.SYS	Controller Link driver
CLKSS.BAT	Controller Link Support Software startup file
Others	Controller Link Support Software files
MSC	MS-C function library directory
CLKMSC.LIB	MS-C function library
CLKMSC.H	MS-C header file
MSCSMPL.C	MS-C sample program (English)
MSCSMPL.C	MS-C sample program (Japanese)
MSCSMPL.EXE	MS-C sample program execution file
DRV	Driver call directory
CLKDRV.H	Driver call header file (MS-C)
DRVSMPLE.C	Driver call sample program (MS-C) (English)
DRVSMPL.C	Driver call sample program (MS-C) (Japanese)
DRVSMPL.EXE	Driver call sample program (execution program)

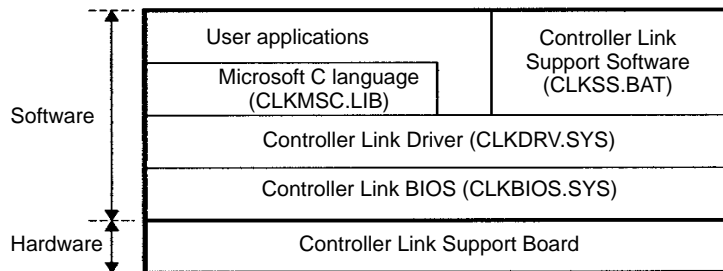

- Note**
1. When the software for the Board is installed, it is installed in the specified directory in the configuration given above.
  2. The file configuration may be changed as a result of version upgrading of the Controller Link Support Board. Check the README.TXT for the current file configuration.

#### 3-1-2 Backing Up the Installation Disk

Files may be erased or data may be corrupted by operation errors during installation. Create a copy of the floppy disk of the Controller Link Support Board and use the disk containing the copy for installation. This will protect the master installation disk should any problem occur. Creation of a disk copy is called backing up the disk.

Prepare one new floppy disk for the backup. After completing the backup, store the master disk (the original floppy disk) carefully. It will be necessary for future version upgrades. Use the copied disk for subsequent operation. If the copy is ever damaged, make a backup copy again. If the master disk is damaged, please return it to OMRON. OMRON will fix or replace the disk for a small charge.

This section describes the backup procedure using the following drive structure as the example. If the drive structure is different, replace the drive name.

Floppy disk drive: Drive A (for 3.5" 2HD floppy disks)

Hard disk drive: Drive C (contains the DOS system)

- Note**
1. Write protect the master (source) disk to ensure that files are not accidentally erased.
  2. Always create a backup copy of the software to provide protection against data corruption.
  3. Use the DISKCOPY command of DOS to back up the disk. The disk to which data is to be copied need not be formatted since DISKCOPY command formats the disk before copying.
  4. The operating system (MS-DOS) is not provided with the Controller Link Support Board software.

### Required Items

New floppy disk (3.5" 2HD): 1

### Backup Procedure

- 1, 2, 3...**
1. Turn on the power of the computer. In this example, the computer is started from the hard disk and command input is prompted as shown below.

```
C:\>
```

**Note** If other applications are running, terminate them and display the DOS command input prompt. Refer to the related manuals for your computer and application software.

2. Write protect the floppy disk containing the Controller Link Support Board software.
3. Enter the following command (underlined section).

```
C:\>DISKCOPY A: A:
```

The following messages will be displayed.

```
Insert SOURCE disk in Drive A:
and press ENTER when ready...
```

4. Insert a disk of the Controller Link Support Software in Drive A.
5. Press the Enter Key. The data on the disk will be read and the following messages will be displayed after a short time.

```
Insert TARGET disk in drive A:
and press ENTER when ready...
```

6. Remove the master disk of the Controller Link Support Board software from drive A and insert a new floppy disk.
7. Press the Enter Key. The data will be written to the new disk.
8. If a message prompts replacing the disk, replace the disk in drive A according to the message.
9. When copying is completed, the following message will be displayed.

```
Create another copy (Y/N)?
```

10. Press the N key. The following message will be displayed immediately.

```
Copy another disk (Y/N)?
```

11. Press the N Key.

**Note** Store the master installation disk carefully.

### 3-2 Installation Method

To enable application of the Controller Link Support Board, carry out the following tasks using the software installer.

- Copy the necessary files to the hard disk.
- Include device drivers (Controller Link BIOS and Controller Link drivers) in CONFIG.SYS.

#### Device Driver

The Controller Link Support Board uses the following device drivers.

#### **Controller Link BIOS (CLKBIOS.SYS)**

This driver controls Controller Link Support Board I/O according to instructions from the application. This driver must be included in the CONFIG.SYS to install it in the computer.

#### **Controller Link Driver (CLKDRV.SYS)**

This driver exchanges data with the BIOS when C language library functions are used or when direct driver calls are made. This driver must be included in the CONFIG.SYS to install it in the computer. This Controller Link driver must be come after the Controller Link BIOS described above. Care is necessary when adding the driver to CONFIG.SYS directly without using the installer.

#### Flow of Installer Operation

Install the software using the following procedure. You can choose to only copy files or to only make changes to CONFIG.SYS.

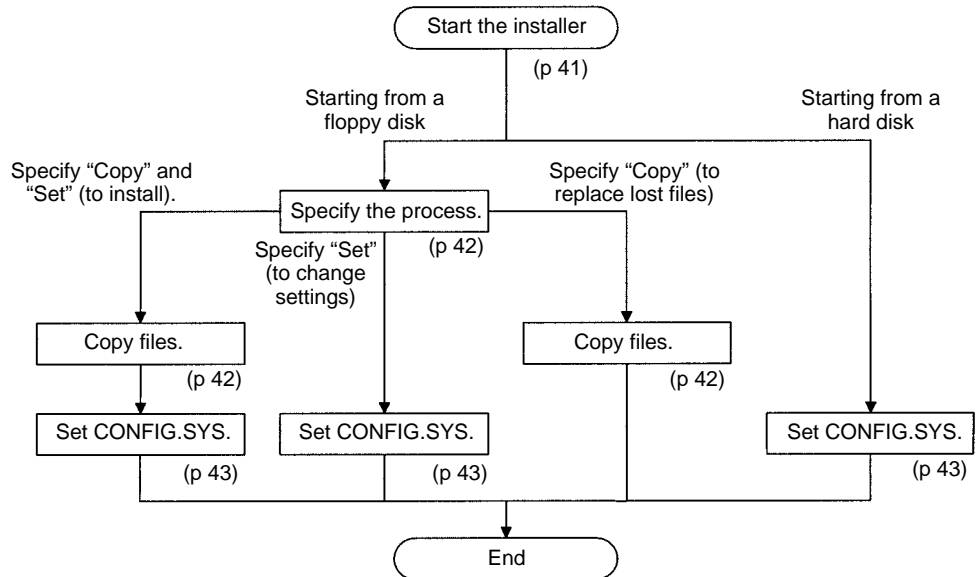

#### 3-2-1 Using the Installer

This section describes how to use the installer using the following example configuration. When the drive configuration is different, replace the drive names with the ones you are actually using.

Floppy disk drive: Drive A  
Hard disk drive: Drive C

- Note** 1. When the setting of CONFIG.SYS is changed, the previous contents are saved under file name CONFIG.BAK. If a file called CONFIG.BAK already exists, the data will be overwritten. To keep the contents of the previous CONFIG.BAK, change the file name as indicated in the underlined section.



**Example:** Changing CONFIG.BAK to CONFIG.OLD.

```
C:\>REN CONFIG.BAK CONFIG.OLD
```

- The following key operations are effective with the installer. The installation method can be changed by returning control to the previous screen or installation can be canceled during operation. The installation will not be complete if it is canceled, and the installation will need to be completed later before using the board.

Keys	Function
Esc	Cancels the screen currently being displayed and returns control to the previous screen.
Ctrl + C	Terminates the installer and cancels installation. Press any key when "Install stop!!" is displayed. Control will be returned to DOS prompt.

## Starting the Installer

The installer starting method varies slightly according to whether the installer is started from a floppy disk or from a hard disk on which it has already been installed.

### Starting from a Floppy Disk

1, 2, 3...

- Insert the installation disk into Drive A.
- Enter as indicated in the underlined section to change the current drive to Drive A.

```
C:\>A:
```

- Start the installer by entering the command indicated below.

```
A:\>INSTALL
```

The installer will start.

### Starting from a Hard Disk

1, 2, 3...

- Change the current directory to the directory containing the Controller Link Support Board software by entering the command shown below.

**Example:** Software Installed in C:\CLK

```
C:\>CD \CLK
```

- Start the installer by entering the following command.

```
C:\CLK\>INSTALL
```

The installer will start.

**Specifying the Process**

- 1, 2, 3... 1. Specify the installer process when the installer has been started from a floppy disk. Move the cursor using the Up and Down Cursor Keys and press the Enter Key.



Control is passed to the following process according to the selection that was made.

- Setting CONFIG.SYS after copying files  
Go to page 42.
- Setting CONFIG.SYS only  
Go to page 43.
- Copy files only  
Go to page 42.

The installer process cannot be specified when starting the installer from a hard disk. When the installer starts, the input screen for the directory name in which the Controller Link files were installed will be displayed and then CONFIG.SYS will be set. (See page 43.)

**Copying Files**

- 1, 2, 3... 1. A copy destination directory specification screen will be displayed. Initially, the following directory will be set: C:\CLK.

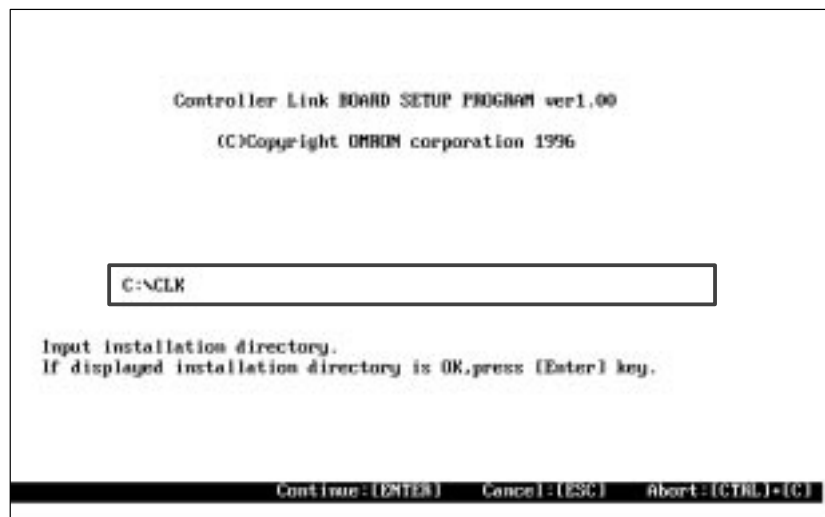

2. Specify the directory to which the Board software is to be copied. If the default directory is okay, press the Enter Key. To change the directory, delete

the existing directory name with the Backspace Key, enter the required directory name, and press the Enter Key. When the specified directory does not exist, it will be created automatically.

3. The files will be copied, and a bar indicating the progress will be displayed on the screen.

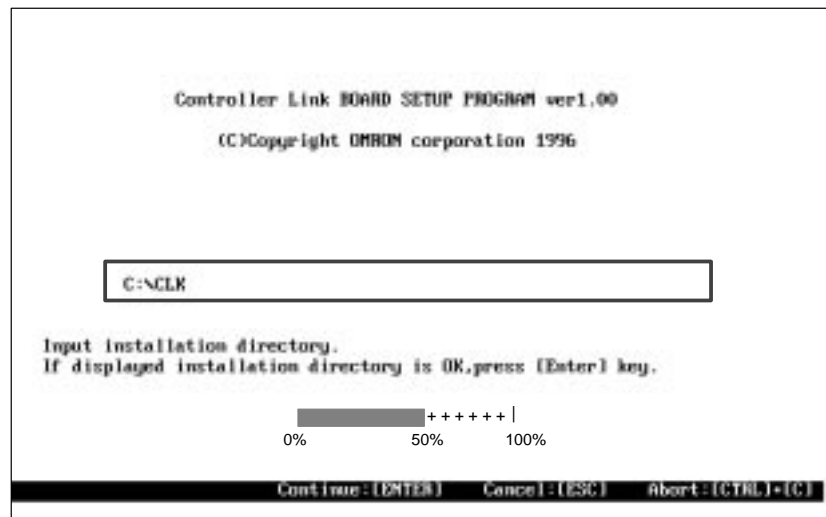

Processing after completion of copying varies according to the specified processing method as follows:

- Setting CONFIG.SYS after file copy  
Go to page 43.
- File copy only  
The installer terminates.

## **Setting CONFIG.SYS**

### **Device Driver Settings**

Set the following for the Board device drivers (Controller Link BIOS and Controller Link driver).

#### **Shared Memory Segment Address**

Set the leftmost four digits in hexadecimal of the base address of the memory area that was set using the memory allocation setting switch (see page 25) of the Board. The following values can be specified.

C000, C200, C400, C600, C800, CA00, CC00, CE00,  
D000, D200, D400, D600, D800, DA00, DC00, DE00

Initially, the value is set to C800 Hex.

- Note** When the value specified for the device driver and the value actually set on the Board are different, an error will occur when BIOS is installed. The same value as that set on the Board switch must be set. (see page 25)

#### **Interrupt Type**

Set the interrupt level that was set using the interrupt short pin (see page 26) on the Board. The following values can be specified.

10, 11, 12, 15

Initially, the value is set to 10.

- Note** When the value specified in the device driver and the value actually set on the Board are different, an error will occur when BIOS is installed. The same value as that set on the Board switch must be set. (see page 26).

#### **Node Address**

Set the node address of the Board on the Controller Link Network in decimal. The node address is used to identify the node on the network. Integers from 1 to 32 can be specified. Node address 1 is set in the initial state.

**Note** This option cannot be omitted. Omitting this will cause an error when incorporating the BIOS.  
 If a value that is not within the specified range is designated, a Parameter Error will occur when the BIOS is incorporated.

**Unit Number**

Set the unit number of the Board on the computer in decimal. The unit number is used to identify the Board within the computer. Integers from 0 to 15 can be specified. Unit number 0 is set in the initial state. Normally, set the unit number to 0. When the message service is used, the unit address of the Controller Link Support Board is determined by adding 10 Hex to this unit number.

**Note** The user program unit address is always 1.

**Baud Rate (Wired Boards Only)**

Set the baud rate for the Wired Controller Link Network. The allowable rates are listed in the following table. The maximum transmission distance of the Controller Link Network depends on the baud rate that is set.

Baud rates	Maximum transmission distance
500 Kbps	1 km
1 Mbps	800 m
2 Mbps	500 m

Initially, the baud rate is set to 2 Mbps.

**Note**

1. If the baud rate that was set is different from those of other nodes, communication will not be possible. Set the same baud rate for all the nodes.
2. The baud rate is fixed at 2 Mbps in Optical Boards, so this setting is ineffective for Optical Boards.

**Startup Mode**

Specify whether the Controller Link Support Board is to be a polling node when it is added to the network.

- Polling node: Start as a polling node
- Polled node : Start as a polled node

The Board is initially set as a polling and should normally be used as a polling node. See 9-1-1 Controller Link Communications for information on polling/pollled nodes.

**Note** The Board may operate as a polling node if the current polling node leaves the network, even if the Board is set as a polled node.

**Data Link Cache**

Set the memory area to be used for the data link cache (always 64 Kbytes). The following settings can be specified.

Data Link Cache
No data link cache (cache not used)
Conventional memory
XMS memory

Initially, XMS memory is set. See Features (page 3) for details on the data link cache.

**Note** To use XMS memory as a cache, HIMEM.SYS must be installed before the Controller Link BIOS in CONFIG.SYS.

**Number of Buffers**

Set the number of send/receive buffers (2,014 bytes per buffer) to be used by the Board in decimal. An integer between 3 and 30 can be specified. Send and receive buffers are allocated as follows according to the number of buffers specified:

Send buffers: Always 1  
Receive buffers: Specified value – 1

Initially, three buffers are allocated, 1 send buffer and 2 receive buffers.

**Startup Drive**

Set the drive containing CONFIG.SYS in which the device drivers are to be registered. If CONFIG.SYS is not to be overwritten, a new file called CONFIG.CLK will be created in the specified drive and device drivers will be entered in this file. Drives from A to Z can be specified. The specified drive must exist.

Initially, the startup drive is set to C.

**Note** Even if device drivers are set, the settings will not be effective unless the computer is restarted from the drive containing the CONFIG.SYS in which the drivers are written.

**Display Mode**

Set whether the device driver startup message will be displayed in Japanese or English. The initial setting is English.

**Note** If the display mode is set to Japanese, the message will not be displayed correctly. For details on startup messages, refer to 3-3 *Confirming Normal Startup*.

**Operation**

- 1, 2, 3...** 1. When the installer is started from a hard disk or only setting CONFIG.SYS is specified, specify the directory in which the Controller Link Support Board Software is installed.

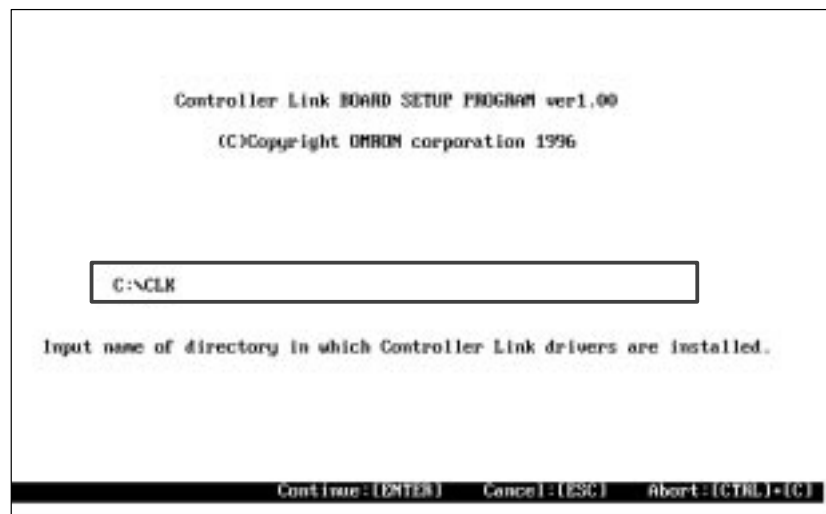

If the default directory is okay, press the Enter Key. To change the setting, delete the existing directory name with the Backspace Key, enter the required directory name, and press the Enter Key.

When setting CONFIG.SYS after copying files, this screen will not be displayed because the copy destination is automatically set.

- Specify whether CONFIG.SYS is to be overwritten. Move the cursor with the Up and Down Cursor Keys and press the Enter Key.

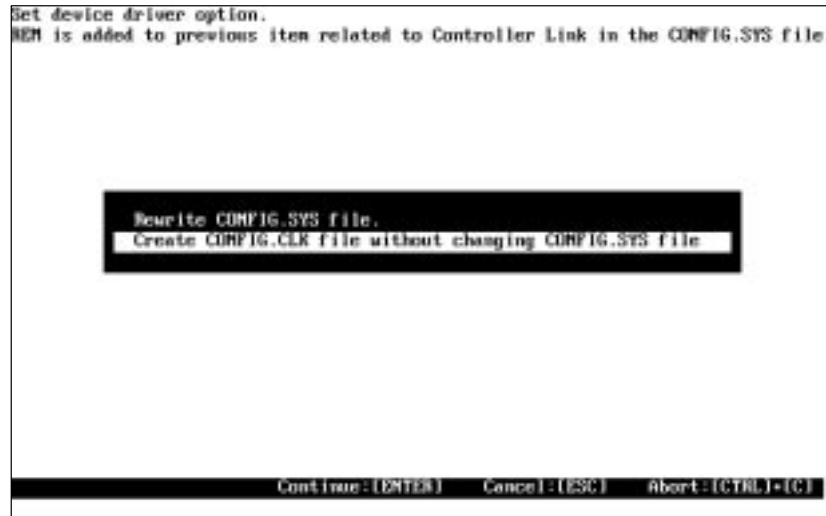

When CONFIG.SYS is overwritten, the contents of the existing CONFIG.SYS are backed up in the file called CONFIG.BAK. When device drivers for Controller Link have already been entered in the existing CONFIG.SYS, the entries are invalidated by attaching “REM” at the beginning of the line and new device driver entries are added.

When CONFIG.SYS is not overwritten, a file called CONFIG.CLK is created and device drivers are entered in this file. Change CONFIG.SYS later by referring to CONFIG.CLK.

When the Enter Key is pressed, the default settings are listed.



- To change a setting, move the arrow to the item to be changed using the Up and Down Cursor Keys and press the Enter Key. The settings that can be specified will be displayed.

**Example:** Change baud rate (“transmission rate”) for a Wired Board.



**Note** The baud rate is fixed at 2 Mbps in Optical Boards, so this setting is ineffective for Optical Boards.

4. Move the cursor to the setting to be specified using the Up and Down Cursor Keys and press the Enter Key. The new setting will be set and control will be returned to the list display.
5. After setting of all the items, move the arrow to “Register in the following setting” using the Up and Down Cursor Keys and press the Enter Key. The new device drivers will be entered in CONFIG.SYS or CONFIG.CLK and messages will be displayed.

```
CONFIG.SYS was rewritten
```

```
The changed contents become effective by restarting  
the personal computer
```

```
The previous CONFIG.SYS was renamed to CONFIG.BAK.
```

```
Press any key
```

**or**

```
CONFIG.CLK was created in the root directory of the  
startup drive
```

```
Rewrite CONFIG.SYS by referencing CONFIG.CLK.
```

```
Press any key
```

6. Press any key to terminate the installer.

### 3-2-2 Installer Troubleshooting

When an error occurs while the installer is used, take the necessary action according to the instructions listed below.

Operation at time of an error	Assumed cause and action
The following error message was displayed: "Cannot install into same directory."	The directory containing INSTALL.EXE was specified. Specify a different directory.
The following error message was displayed: "Copy destination is incorrect."	An incorrect installation destination was specified. Specify a correct installation destination.
The installer terminated by displaying the following error message: "Access denied - CONFIG.SYS."	Write protection is set for the existing CONFIG.SYS or CONFIG.BAK. Release the write protection on CONFIG.SYS or CONFIG.BAK.
	A directory named CONFIG.SYS or CONFIG.BAK exists. Change the directory name.
The installer terminated by displaying the following error message: "Access denied - CONFIG.CLK."	A directory named CONFIG.CLK exists. Change the directory name.
	Write protection is set for the existing CONFIG.CLK. Release the write protection on CONFIG.CLK.
The Controller Link Support Board file directory specification is not accepted even if the directory containing the files is specified.	The specified directory does not exist or the files are not installed in the directory. Check the directory of the installation destination.
The following error message is displayed: "Access denied - INSTALL.INF."	The file named INSTALL.INF does not exist or the contents of the file are corrupt. When using a floppy disk, remake the backup disk from the original installation disk. When using a hard disk, re-install.
The following error message is displayed: "Disk access failure."	Any of the following causes are possible:  The necessary files do not exist, the files are corrupt, the floppy disk drive or hard disk drive is defective, or there is not enough space on the installation destination hard disk.  Check the the file or drive. At least 2 MB is required to install Controller Link Support Board software. Delete unneeded files to create sufficient space.

### 3-2-3 Driver Options in CONFIG.SYS

Enter the items to be set by the installer in CONFIG.SYS as described in this section. Use the information for directly changing CONFIG.SYS.

- Note**
1. Install the Controller Link driver after the Controller Link BIOS.
  2. The Controller Link BIOS and the Controller Link driver cannot be installed using DEVICEHIGH= (UMB). They must be installed using DEVICE= (conventional memory).

#### Controller Link BIOS

**Format**

```
DEVICE=[ drive: ][ directory\ ]CLKBIOS.SYS[ options ]
      (Options: /An, /K, /In, /Nn, /Un, /Bn)
```

For the *drive* and *directory*, specify the names of the drive and directory (absolute specification from the root directory) containing the BIOS file (CLKBIOS.SYS).

**Options**

BIOS operation can be controlled using options. Available options are described below.

- Note**
1. Option specifications are not case sensitive.
  2. Any combination of options is allowed. Options can be specified in any sequence. Options can be omitted.
  3. If an option other than /An, /K, /In, /Nn, /Un, Bn, and /Cn is specified, a parameter error will occur when setting up the BIOS.



**/An — Memory Area**

For n, set the leftmost four digits in hexadecimal of the base address of the memory area that was set using the memory allocation setting switch on the Board. The following values can be specified for n

C000, C200, C400, C600, C800, CA00, CC00, CE00,  
D000, D200, D400, D600, D800, DA00, DC00, DE00

Default when /An is omitted: C800 Hex.

**Example:** Setting CE000 Hex

/ACE00

- Note**
1. When the value of n (or default value) is different from the value actually set on the Board, an error will occur when the BIOS is installed. The value must be the same as the Board switch setting value (see page 25).
  2. If an illegal value is specified, a parameter error will occur when the BIOS is installed.
  3. It may be necessary to install a Plug & Play BIOS depending on the computer model or other boards being used. Refer to your computer documentation.

**/E – English Message Mode**

Use this option to display the BIOS startup message in English.

- Note** When /E option is omitted, the message will not be displayed correctly. For details on startup messages, refer to 3-3 *Confirming Normal Startup*.

**/K — Polled Node**

Specify this option when starting the Controller Link Support Board as a polled node. When option /K omitted, the support board will be started as a polling node. See 9-1-1 *Controller Link Communications* for details on polling and polled nodes.

**/In — Interrupt Level**

Set n to the value of the interrupt level that was set on the interrupt short pin on the Board. The following values can be specified for n.

10, 11, 12, 15

Default when /In is omitted: 10.

**Example:** Setting Interrupt Level 12

/I12

- Note**
1. When the value of n (or default value) is different from the value actually set on the Board, an error will occur when the BIOS is installed. The value must be the same as the board switch setting value (see page 26).
  2. When an illegal value is specified, a parameter error will occur when the BIOS is installed.
  3. It may be necessary to install a Plug & Play BIOS depending on the computer model or other boards being used. Refer to your computer documentation.

**/Nn — Node Address**

Set n to the node address of the Board in the Controller Link Network in decimal. The node address is used to identify the node on the network. A value between 1 and 32 can be specified.

**Example:** Setting the node address to 32.

/N32

- Note**
1. This option cannot be omitted. If the option is omitted, an error will occur when the BIOS is installed.

2. If an illegal value is specified, a parameter error will occur when the BIOS is installed.

**/Un — Unit Number**

Set n to the unit number of the Board in the computer in decimal. The unit number is used to identify the Board in the computer. A value between 0 and 15 can be specified.

Default when /Un is omitted: 0

Normally, use 0. When the message service is used, the unit address of the Controller Link Support Board is determined by adding 10 Hex to the unit number.

**Example:** Setting the unit number to 0.

/U0

- Note**
1. If an illegal value is specified, a parameter error will occur when the BIOS is installed.
  2. The unit address of the user program is always 1.

**/Bn — Baud Rate (Wired Boards Only)**

Set n to the baud rate of the Controller Link Network. The values that can be specified for n are listed below. The maximum transmission distance of the Controller Link Network depends on the baud rate that is set.

Value of n	Baud rate	Maximum transmission distance
1	500 Kbps	1 km
2	1 Mbps	800 m
3	2 Mbps	500 m

Default when /Bn is omitted: 2 Mbps

**Example:** Setting the baud rate to 2 Mbps

/B3

- Note**
1. If the baud rate that was set is different from the rates of other nodes, communications will not be possible. The baud rate must be the same at all nodes.
  2. If an illegal value is specified, a parameter error will occur when the BIOS is installed.
  3. The baud rate is fixed at 2 Mbps in Optical Boards, so this setting is ineffective for Optical Boards.

**/Cn — Data Link Cache**

Set n to the memory area to be used for the data link cache (always 64 Kbytes). The following values can be specified for n.

Value of n	Data link cache area
0	No data link cache area (data link cache not used)
1	Conventional memory
2	XMS memory

Default when /Cn is omitted: XMS memory

See *Features* (page 3) for details on the data link cache.

**Example:** Setting the XMS memory

/C2

- Note**
1. When setting the data link cache in XMS memory, install HIMEM.SYS (DEVICE=HIMEM.SYS) before Controller Link BIOS in CONFIG.SYS.
  2. If an illegal value is specified, a parameter error will occur when the BIOS is installed.

## Controller Link Driver

### Format

```
DEVICE=[ drive: ][ directory\ ]CLKDRV.SYS[ option]  
(Options: /Bn)
```

For the *drive* and *directory*, specify the names of the drive and directory (absolute specification from the root directory) containing the driver file (CLKDRV.SYS).

### Option

The driver operation can be controlled using an option. The option is described below.

- Note**
1. Option specification are case-sensitive.
  2. If an option other than /Bn is specified, a parameter error will occur when the BIOS is installed.

#### **/E – English Message Mode**

Use this option to display the driver startup message in English.

- Note** When /E option is omitted, the message will not be displayed correctly. For details on startup messages, refer to 3-3 *Confirming Normal Startup*.

#### **/Bn — Number of Buffers**

Set n to the number of send/receive buffers (2,014 bytes per buffer) to be used by the Board in decimal. An integer between 3 and 30 can be specified. Send and receive buffers are allocated as follows according to the number of buffers specified by n:

Send buffers: Always 1

Receive buffers: Specified value – 1

Default when /Bn is omitted: 1 send buffer and 2 receive buffers

**Example:** Setting 10 receive buffers

```
/B11
```

- Note**
1. The Controller Link driver must not be installed before the Controller Link BIOS in CONFIG.SYS.
  2. If an illegal value specified, a parameter error will occur when the BIOS is installed.

### 3-3 Confirming Normal Startup

This section describes how to confirm that the Board and its device drivers have started normally.

**Note** When a backup power supply is connected to an Optical Board for the node bypass function, turn ON the backup power supply before or at the same time as the computer's power supply. A communications error may occur if the backup power supply is turned ON or OFF while the Controller Link Support Board is operating.

#### 3-3-1 Controller Link BIOS

When the computer is restarted after changing CONFIG.SYS, the Controller Link BIOS will be installed. The following message will be displayed if the Link BIOS starts normally.

```
Controller Link BIOS Ver.1.10 (_____)
(c)Copyright OMRON Corporation 1996-1998
```

The board type is displayed as "PC/AT" in the underlined section.

**Errors**

If a driver or a board cannot be started due to an error, the following message will be displayed.

```
Controller Link BIOS Ver.1.10
(c)Copyright OMRON Corporation 1996-1998
not installed.
(_____)
```

One of the error messages that are listed below will be displayed in the underlined section, Take the necessary action according to the message.

Error message	Action
Controller Link Board not installed.	Install the Controller Link Support Board. Check to be sure the memory area set for the Controller Link Support Board and the memory area set for the Controller Link BIOS are the same.
Invalid parameter. (/A /I /T /N /U /B /C) *	Check the settings of the parameters (options) that are displayed. For /A and /I, check to be sure the setting of the Controller Link Support Board and the setting of the Controller Link BIOS are the same. Check also for overlaps with other devices. For /C1, check if DEVICEHIGH= was set. (DEVICEHIGH cannot be used.) For /C2, allocate XMS memory of 64 Kbytes or more.
Controller Link Board hardware error.	Replace the Controller Link Support Board.

\*Only incorrect parameters are displayed.

#### 3-3-2 Controller Link Driver

When the computer is restarted after changing CONFIG.SYS, the Controller Link BIOS and Controller Link driver will be installed. The following message will be displayed if Controller Link BIOS starts normally.

```
Controller Link DRIVER Ver.1.10
(c)Copyright OMRON Corporation 1996-1998
```

**Errors**

If the a driver or the Board cannot be started due to an error, the following message will be displayed.

```
Controller Link DRIVER Ver.1.00
(c)Copyright OMRON Corporation 1996
not installed.
(_____)
```

One of the error messages that are listed below will be displayed in underlined section. Take the necessary action according to the message.

Error message	Action
Controller Link BIOS not installed.	Install the Controller Link BIOS.
Invalid parameter. (/B)	Check the setting of the number of buffers. Check if DEVICEHIGH= is set. (DEVICEHIGH cannot be used.)

**3-3-3 Board Indicators**

Normal startup can be confirmed by checking the LED indicators on the Board. The indicator section on the Board is shown below.

**Wired Board**

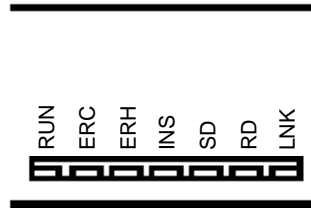

The normal status of the indicators is shown in the following table.

Indicator	Color	Normal status	Error status
RUN	Green	Lit	Not lit
ERC	Red	Not lit	Lit
ERH	Red	Not lit	Lit
INS	Yellow	---	---
SD	Yellow	---	---
RD	Yellow	---	---
LNK	Yellow	---	Flashing

**Optical Board**

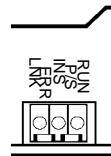

The normal status of the indicators is shown in the following table.

Indicator	Color	Normal status	Error status
RUN	Green	Lit	Not lit
ERR	Red	Not lit	Lit
INS	Yellow	---	---
LNK	Yellow	---	Flashing
P/S	Green	---	---

An error status for an indicator shows that an error has occurred. Take the necessary action by referring to 10-1 Troubleshooting Using Indicators.

# SECTION 4

## Creating Applications

This section describes how to create applications (user programs) that control the Controller Link Support Board.

- 4-1 Basic Flow .....
- 4-1-1 Data Link Procedure .....
- 4-1-2 Message Service Procedure .....
- 4-2 MS-C Library .....
- 4-3 Driver Calls .....
- 4-4 Sample Program .....

## 4-1 Basic Flow

This section describes the basic procedural flow in creating the applications (user programs) necessary to use the Controller Link Support Board data link function and the message service function. Create the applications according to the flow charts in this section.

The following explanations assume that the BIOS and driver have already been installed. If they have not been, refer to *Section 3 Software Installation* before proceeding.

### 4-1-1 Data Link Procedure

The basic procedure for using data links is outlined in the following flowchart.

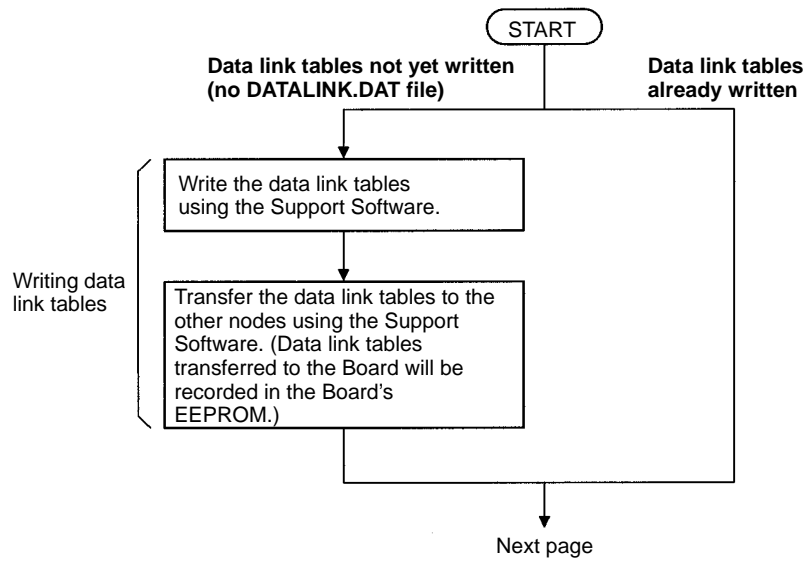

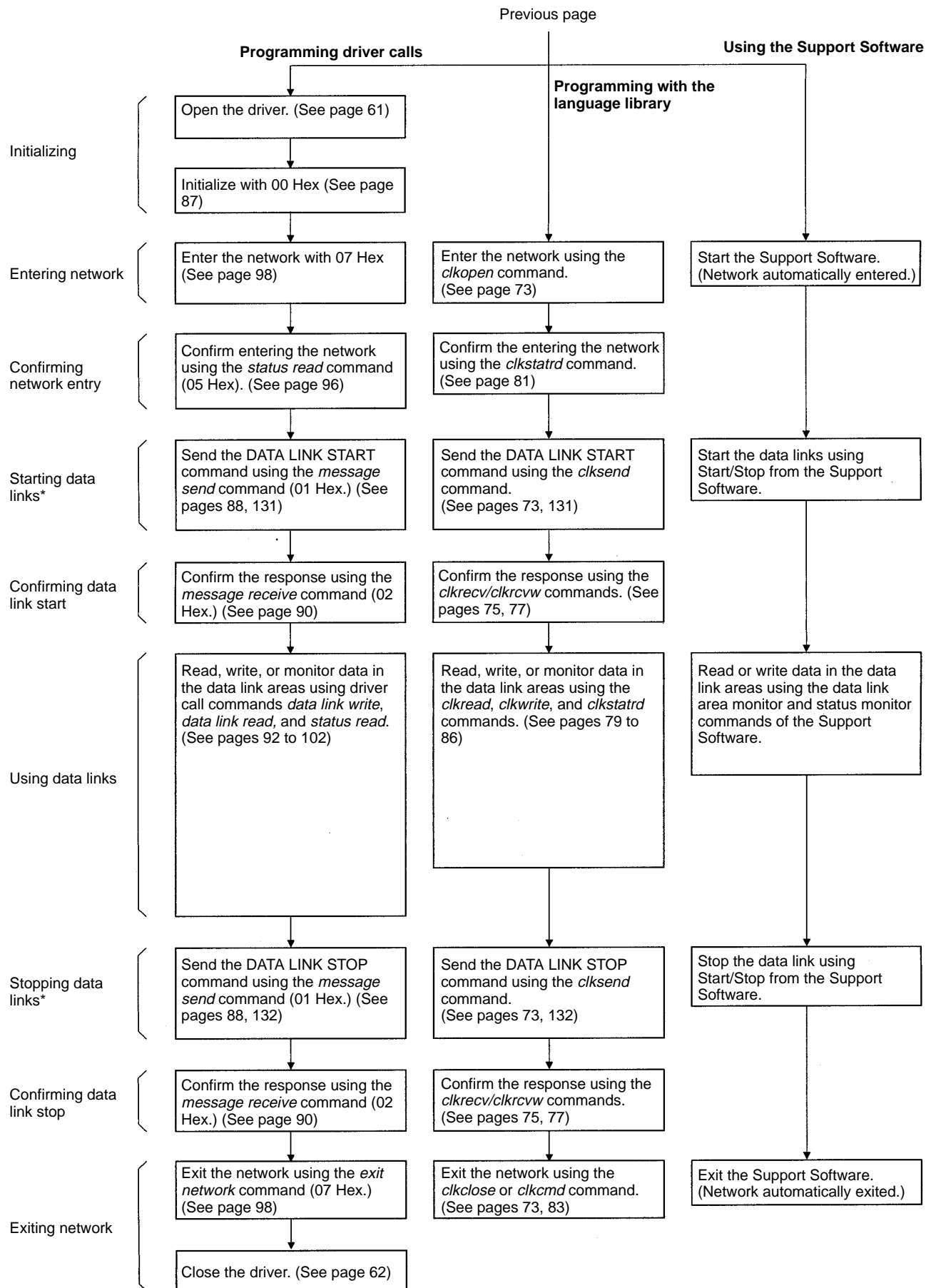



**Note** \*The data links can also be started or stopped from a Programming Device or by sending CV-mode commands (DATA LINK START and DATA LINK STOP) from other nodes.

For details on various methods for making programs, refer to the following resources.

- Using the Microsoft C library: *4-2 MS-C Library*
- Using driver calls: *4-3 Driver Calls*
- Details on library functions and driver calls: *Section 5 Commands and Driver Call Reference*
- Usage example: *4-4 Sample Program*
- Using the Support Software: *Controller Link Support Software Operation Manual (W308)*.

### 4-1-2 Message Service Procedure

The basic procedure for using the message service is outlined in the following flowchart.

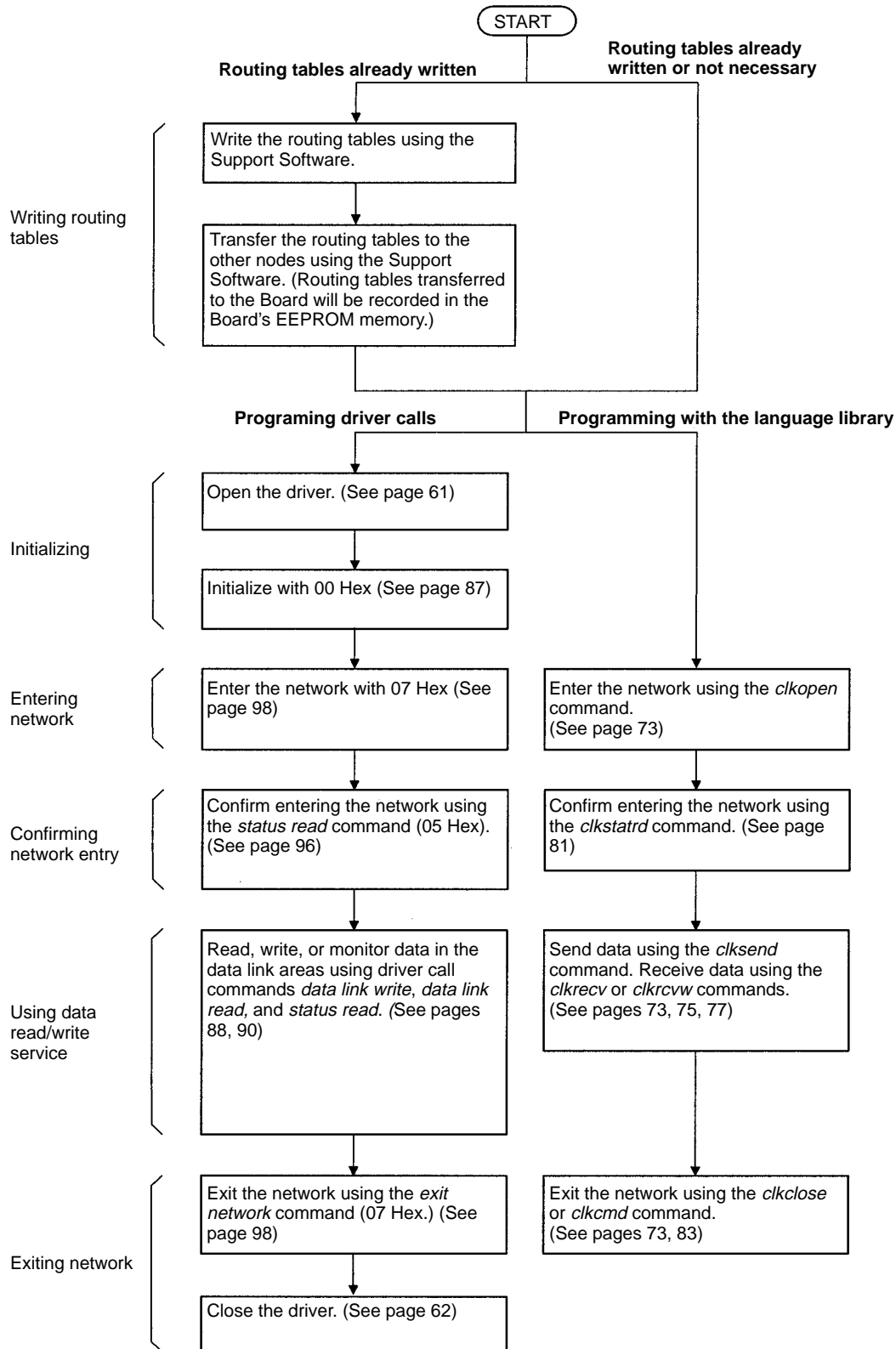

**Note** Routing tables are not needed if all communications take place with other nodes in the local network, but routing tables must be prepared if there are communications between nodes on different networks.

For details on various methods for making programs, refer to the following references.

- Using the Microsoft C library: *4-2 MS-C Library*
- Using driver calls: *4-3 Driver Calls*
- Details on library functions and driver calls: *Section 5 Commands and Driver Call Reference*
- Usage example: *4-4 Sample Program*
- Using the Support Software: *Controller Link Support Software Operation Manual (W308)*.

## 4-2 MS-C Library

The MS library functions for the Support Board are contained in the following file.

File name: CLKMSC.LIB  
 Contents: Library file for MS-C (Microsoft C) Ver 7.0.

### Commands

The commands in the C library are described in the following table.

Command	Function	Page
<i>clkopen</i>	Opens the Controller Link driver and adds the Support Board to the network.	73
<i>clkclose</i>	Closes the Controller Link driver and removes the Support Board from the network.	73
<i>clksend</i>	Transmits a message or FINS command.	73
<i>clkrecv</i>	Receives a message or FINS command.	75
<i>clkrcvw</i>	Receives a message or FINS command. The time that the Support Board waits for the message can be specified with this command.	77
<i>clkread</i>	Reads data from the data link area (with data link cache).	79
<i>clkwrite</i>	Writes data to the data link area (with data link cache).	80
<i>clkstatrd</i>	Checks the operational status of the Support Board.	81
<i>clkcmd</i>	Adds/removes the Support Board to/from the network.	83
<i>clkread2</i>	Reads data from the data link area (without data link cache).	83
<i>clkwrite2</i>	Writes data to the data link area (without data link cache).	85

### Using the MS-C Library

The MS-C library commands are used in the following ways.

#### Using the Commands

Use the commands listed in the above table in the user program and the functions will be executed.

#### Compiler

When using the compiler function, always set the program model to large. Enter the following command to compile the library:

```
cl /AL /Zp /c source_filename
```

#### Links

Enter the following command to link to the library with the object file output after compiling:

```
link object_filename,,,clkmsc.lib
```

## 4-3 Driver Calls

Calls can be made directly to the Controller Link driver and the port controlled without using the MS-C library. The services listed in the following table are available in the Controller Link driver.

Function	Function code	Page
Initializes the Support Board.	00 Hex	87
Transmits a message.	01 Hex	88
Receives a message.	02 Hex	90
Reads data from a data link area (with cache).	03 Hex	92
Writes data to a data link area (with cache).	04 Hex	94
Checks the operational status of the Support Board.	05 Hex	96
Adds/removes the Support Board to/from the network.	07 Hex	98
Reads data from a data link area (without cache).	20 Hex	98
Writes data to a data link area (without cache).	21 Hex	100

### Making Driver Calls

When calling the driver directly, first open the driver via DOS. This will enable recognition of file extensions called "file handles." Send I/O requests (to access the driver) using these file handles to use driver services. When finished using the driver, close the driver via DOS.

- 1, 2, 3...
1. Open the file.
  2. I/O request (driver access).
  3. Close the file.

Once the Controller Link driver is open, the driver services can be used repeatedly until the driver is closed. Accordingly, the driver should be opened when the program is initialized and closed when the program is finished.

### Opening Files

To open the Controller Link driver, set the AX, DS, and DX registers as follows and use the DOS INT21 Hex system call:

#### Call Method

AX ← 3D02 Hex

DS:DX ← The first address storing the "CLKDRV\$" text string (segment:offset.)

INT 21 Hex

The driver name "CLKDRV\$" is stored in ASCII with "00 Hex" (null) on the end.

#### Return Values

##### **Normal Completion**

Carry flag: Clear (0)

AX: File handle

##### **Error Completion**

Carry flag: Set (1)

AX: **Error Code**

02 Hex: File not found

03 Hex: Path not found

04 Hex: Too many files open

05 Hex: Access denied

0C Hex: Access code not valid (an error in the AX register command.)

See your DOS manual for further details.

If the driver files open normally, the Controller Link driver can be accessed by specifying the file handle returned in the AX register as the return value.

**I/O Requests (Accessing the Driver)**

After the Controller Link driver is open, Board control commands are written in "user command packets." Next, AX, BX, CX, DS, and DX registers are set and a DOS INT 21 Hex system call is made.

**Call Method**

User Command Packet = Board Control Command

AX ← 4403 Hex

BX ← File handle (the return value when a file is opened)

CX ← Total number of bytes in user command packet.

DS:DX ← The first address storing the command packet (segment:offset).

INT 21 Hex

The driver is normally accessed using the method described above. The user command packet consists of a single byte function code giving the control command and data indicating the control details. See *4-3 Driver Calls* for details.

**Example:** Initialize (Function code: 00Hex)

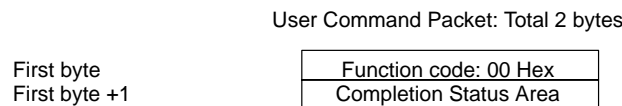
**Return Value****Normal Completion**

Carry flag: Clear (0)

AX: Number of bytes in user command packet (the number of bytes transmitted.)

**Error Completion**

Carry flag: Set (1)

AX: **Error Code**

01 Hex: Invalid function code

05 Hex: Access denied

06 Hex: File handle not valid

0D Hex: Data not valid

See your DOS manual for further details.

The completion status from the Controller Link driver is set in the completion status area for each control command. For details, refer to *4-3 Driver Calls*. The above I/O request can be used continuously on the same file handle while the Controller Link driver is open.

**Note** This I/O request is the DOS system call to send control data to a character device.

**Closing Files**

To close the Controller Link driver, set the AH and BX registers as follows and use the DOS INT 21 Hex system call:

**Call Method**

AX ← 3H Hex

BX ← File handle (the return value when a file is opened)

INT 21 Hex

**Return Value****Normal Completion**

Carry Flag: Clear (0)

**Error Completion**

Carry flag: Set (1)

AX: **Error Code**

06 Hex: File handle is not valid.

See your DOS manual for further details.

After closing the file the Controller Link Support Board cannot be controlled until the file is opened again.

## 4-4 Sample Program

The following sample program checks the basic functions of the main Board. Refer to this program when developing your own programs. This sample program is for use with the MS-C library only, but sample programs for other libraries and for driver calls are available in the directories.

**Sample Program**

This sample program reads 5 words of data beginning with DM 3000 from node address 1 of the local network.

```

/*****
/*      Controller Link MS-C Library Sample Program      */
/*      Compile -> cl /AL /Zp /c mscsmpl.c              */
/*      Link    -> link mscsmpl,,,clkmsc.lib;          */
*****/

#include <stdio.h>
#include <stdlib.h>
#include <conio.h>
#include <math.h>
#include "clkmsc.h"

void menu(void);
void t_open(void);
void t_close(void);
void t_snd(void);
void t_rcv(void);
void t_rcvw(void);
void t_read(void);
void t_writ(void);
void t_read2(void);
void t_writ2(void);
void t_stat(void);
void t_jcmd(void);

unsigned char tmp[64000]; /* Work area */
unsigned char buf[64000]; /* Work area */

void menu(void) /** Function menu **/
{
    int c;

    while(1) {
        printf("\n\nSample Program");
        printf("\n1.clkopen 2.clkclose 3.clksend 4.clkrcv 5.clkrcvw");
        printf("\n6.clkread 7.clkwrite 8.clkstatrd 9.clkcmd 0.Quit");
        printf("\na.clkread2 b.clkwrite2");
        printf("\nSelect number.");
    }
}

```

```
get_next_char:
    c = getch(); /* Key input */

    switch (c) {
    case '\n':
    case '\r':
        goto get_next_char;
        /* If only Enter key is pushed, goes up to 'get_next_char' */
    default:
        continue;
    case '0':
        return;
    case '1':
        t_open();
        break;
    case '2':
        t_close();
        break;
    case '3':
        t_send();
        break;
    case '4':
        t_rcv();
        break;
    case '5':
        t_rcvw();
        break;
    case '6':
        t_read();
        break;
    case '7':
        t_writ();
        break;
    case '8':
        t_stat();
        break;
    case '9':
        t_jcmd();
        break;
    case 'a':
    case 'A':
        t_read2();
        break;
    case 'b':
    case 'B':
        t_writ2();

    }
}

void t_open(void) /** DRIVER & NETWORK open **/
{
    int ret; /* Return value of this function */

    printf("\n\nl.clkopen");
    ret = clkopen();
    printf("\n\nReturn value: %d", ret); /* Display return value */
}

void t_close(void) /** DRIVER & NETWORK close **/
{
```

```

int ret; /* Return value of this function */

printf("\n\n2.clkclose");
ret = clkclose();
printf("\n\nReturn value: %d", ret); /* Display return value */
}

void t_send(void) /** Send a message **/
{
    struct clkio snd;
    int c; /* Variable of key input */
    int ret; /* Return value of this function */
    int n,i; /* Variable */
    unsigned int this_length; /* Message length */

    printf("\n\n3.clksend");

    printf("\n\nNet(0-127) : ");
    gets(tmp);
    snd.netadr = (unsigned int)atoi(tmp);

    printf("Node(0-126,255) : ");
    gets(tmp);
    snd.nodeadr = (unsigned int)atoi(tmp);

    printf("Unit(0-254) : ");
    gets(tmp);
    snd.unitadr = (unsigned int)atoi(tmp);

    printf("Type(0,1,2) : ");
    gets(tmp);
    snd.type = (unsigned int)atoi(tmp);

    printf("Sid(0-255) : ");
    gets(tmp);
    snd.sid = (unsigned int)atoi(tmp);

    printf("Length(2-2002byte) : ");
    gets(tmp);
    this_length = (unsigned int)atoi(tmp);

    printf("Data(0-9,a-f) : ");
    i = 0;
    do { /* Put the input character to character string(tmp) */
        if ('0' <= (c = getch()) && c <= '9' || 'a' <= c && c <= 'f') {
            putchar(c);
            tmp[i++] = (unsigned char)c;
        }
        else if (c == '\b' && 0 < i) {
            printf("\b\b");
            i--;
        }
    } while (i % 2 || c != 0x0d);
    n = i;
    for (i = 0; i < n; i++) { /* Convert from character string to numerical value
*/
        buf[i / 2] = buf[i / 2] << 4;
        if ('0' <= tmp[i] && tmp[i] <= '9') {
            buf[i / 2] = buf[i / 2] | (tmp[i] - '0');
        }
        else if ('a' <= tmp[i] && tmp[i] <= 'f') {
            buf[i / 2] = buf[i / 2] | (tmp[i] - 'a' + 10);
        }
    }
}

```



```

    }
}
snd.text = buf;
if (this_length == 0)
    this_length = n / 2;

ret = clksend(&snd, this_length);
printf("\n\nReturn value: %d", ret); /* Display return value */
}

void t_rcv(void) /** Receive a message**/
{
    struct clkio rcv;
    int ret;          /* Return value of this function */
    unsigned int len /* Message length                */
                , i; /* Variable                    */
    printf("\n\n4.clkrcv");

    printf("\n\nLength(2-2002byte) : ");
    gets(tmp);
    len = (unsigned int)atoi(tmp);

    rcv.text = buf;

    ret = clkrcv(&rcv, len);
    printf("\nReturn value: %d", ret); /* Display return value */

    if (ret > 0) {
        printf("\n\nNet  :%3d Node:%3d Unit:%3d Type:%3d Sid  :%3d", rcv.netadr,
rcv.nodeadr, rcv.unitadr, rcv.type, rcv.sid);

        for (i = 0; i < len && i < (unsigned int)ret; i++) {
            if (i % 10 == 0) /* Insert 'Space' every 10 characters */
                printf (" ");
            if (i % 30 == 0) /* Insert 'CR' every 30 characters      */
                printf("\n");
            printf("%02x", rcv.text[i]);
        }
    }
}

void t_rcvw(void) /** Receive a message(Set waiting time)**/
{
    struct clkio rcv;
    int ret;          /* Return value of this function */
    unsigned int len /* Message length                */
                , tim /* waiting time                */
                , i; /* Variable                    */
    printf("\n\n5.clkrcvw");

    printf("\n\nLength(2-2002byte) : ");
    gets(tmp);
    len = (unsigned int)atoi(tmp);

    printf("time(0-255) : ");
    gets(tmp);
    tim = (unsigned int)atoi(tmp);

    rcv.text = buf;

```

```

ret = clkrcvw(&rcv, len, tim);
printf("\nReturn value: %d", ret); /* Display return value */

if (ret > 0) {
    printf("\n\nNet  :%3d Node:%3d Unit:%3d Type:%3d Sid  :%3d", rcv.netadr,
rcv.nodeadr, rcv.unitadr, rcv.type, rcv.sid);

    for (i = 0; i < len && i < (unsigned int)ret; i++) {
        if (i % 10 == 0) /* Insert 'Space' every 10 characters */
            printf (" ");
        if (i % 30 == 0) /* Insert 'CR' every 30 characters */
            printf("\n");
        printf("%02x", rcv.text[i]);
    }
}

}

void t_read(void) /** DataLink data read(with cache) **/
{
    unsigned int siz /* Read data length */
                ,off /* Offset address */
                ,i; /* Variable */
    int ret; /* Return value of this function */
    printf("\n\n6.clkread");

    printf("\n\nSize(2-64000byte) : ");
    gets(tmp);
    siz = (unsigned int)atol(tmp);

    printf("Offset(0-63998byte) : ");
    gets(tmp);
    off = (unsigned int)atol(tmp);

    ret = clkread(buf, siz, off);
    printf("\nReturn value: %d", ret); /* Display return value */

    if (!ret) {
        printf("\n");
        for (i = 0; i < siz; i++) {
            if (i % 10 == 0) /* Insert 'Space' every 10 characters */
                printf (" ");
            if (i % 30 == 0) /* Insert 'CR' every 30 characters */
                printf("\n");
            printf("%02x", buf[i]);
        }
    }
}

void t_writ(void) /* DataLink data write(with cache) */
{
    unsigned int siz /* Write data length */
                ,off /* Offset address */
                ,n,i; /* Variable */
    int ret; /* Return value of this function */
    int c; /* Variable of key input */

    printf("\n\n7.clkwrite");

    printf("\n\nData(0-9,a-f) : ");

    i = 0;

```

```

do { /* Put the input character to character string(tmp) */
    if ('0' <= (c = getch()) && c <= '9' || 'a' <= c && c <= 'f') {
        putchar(c);
        tmp[i++] = (unsigned char)c;
    }
    else if (c == '\b' && 0 < i) {
        printf("\b \b");
        i--;
    }
} while (i % 2 || c != 0x0d);
printf("\n");

n = i;

for (i = 0; i < n; i++) {
    /* Convert from character string to numerical value */
    buf[i / 2] = buf[i / 2] << 4;
    if ('0' <= tmp[i] && tmp[i] <= '9') {
        buf[i / 2] = buf[i / 2] | (tmp[i] - '0');
    }
    else if ('a' <= tmp[i] && tmp[i] <= 'f') {
        buf[i / 2] = buf[i / 2] | (tmp[i] - 'a' + 10);
    }
}
siz = n / 2;

printf("Offset(0-63998byte) : ");
gets(tmp);
off = (unsigned int)atol(tmp);

ret = clkwrite(buf, siz, off);
printf("\n\nReturn value: %d", ret); /* Display return value */
}

void t_read2(void) /** DataLink data read(no cache) **/
{
    unsigned int siz      /* Read data length          */
        ,off            /* Offset address          */
        ,i;             /* Variable                */
    int ret;             /* Return value of this function */
    unsigned char node; /* Node address            */

    printf("\n\na.clkread2");

    printf("\n\nSize(2-2000byte) : ");
    gets(tmp);
    siz = (unsigned int)atoi(tmp);

    printf("Offset(0-1998byte) : ");
    gets(tmp);
    off = (unsigned int)atoi(tmp);

    printf("Node(1-32) : ");
    gets(tmp);
    node = (unsigned char)atoi(tmp);

    ret = clkread2(buf, siz, off,node);
    printf("\n\nReturn value: %d", ret); /* Display return value */

    if (!ret) {
        printf("\n\n");
        for (i = 0; i < siz; i++) {

```

```

        if (i % 10 == 0) /* Insert 'Space' every 10 characters */
            printf (" ");
        if (i % 30 == 0) /* Insert 'CR' every 30 characters */
            printf("\n");
        printf("%02x", buf[i]);
    }
}

void t_writ2(void) /** DataLink data write(no cache) **/
{
    unsigned int siz    /* Write data length */
        ,off          /* Offset address */
        ,n,i;        /* Variable */
    int ret;          /* Return value of this function */
    int c;            /* Variable of key input */
    unsigned char node; /* Node address */

    printf("\n\nb.clkwrite2");

    printf("\n\nData(0-9,a-f) : ");

    i = 0;
    do { /* Put the input character to character string(tmp) */
        if ('0' <= (c = getch()) && c <= '9' || 'a' <= c && c <= 'f') {
            putchar(c);
            tmp[i++] = (unsigned char)c;
        }
        else if (c == 'b' && 0 < i) {
            printf("\b \b");
            i--;
        }
    } while (i % 2 || c != 0x0d);
    printf("\n");

    n = i;

    for (i = 0; i < n; i++) {
        /* Convert from character string to numerical value */
        buf[i / 2] = buf[i / 2] << 4;
        if ('0' <= tmp[i] && tmp[i] <= '9') {
            buf[i / 2] = buf[i / 2] | (tmp[i] - '0');
        }
        else if ('a' <= tmp[i] && tmp[i] <= 'f') {
            buf[i / 2] = buf[i / 2] | (tmp[i] - 'a' + 10);
        }
    }

    siz = n / 2;

    printf("Offset(0-1998byte) : ");
    gets(tmp);
    off = (unsigned int)atoi(tmp);

    printf("Node(1-32);");
    gets(tmp);
    node = (unsigned char)atoi(tmp);

    ret = clkwrite2(buf, siz, off, node);
    printf("\n\nReturn value: %d", ret); /* Display return value */
}

```

```
void t_stat(void) /** Status read **/
{
    unsigned int len /* Data length */
                ,i; /* Variable */
    int ret; /* Return value of this function */

    printf("\n\n8.clkstatrd");

    printf("\n\nLeng(1-68) : ");
    gets(tmp);
    len = (unsigned int)atoi(tmp);

    ret = clkstatrd(buf, len);
    printf("\nReturn value: %d", ret); /* Display return value */

    if (!ret) {
        printf("\n");
        for (i = 0; i < len; i++) {
            if (i % 10 == 0) /* Insert 'Space' every 10 characters */
                printf (" ");
            if (i % 30 == 0) /* Insert 'CR' every 30 characters */
                printf("\n");
            printf("%02x", buf[i]);
        }
    }
}

void t_jcmd(void) /** Command **/
{
    int cmd; /* Variable of command */
    int ret; /* Return value of this function */

    printf("\n\n9.clkcmd");

    printf("\n\nCmd(0,1) : ");
    gets(tmp);
    cmd = atoi(tmp);

    ret = clkcmd(cmd);
    printf("\nReturn value: %d", ret); /* Display return value */
}

void main() /* Main function */
{
    menu();
}
```

# SECTION 5

## Commands and Driver Call Reference

This section gives details on the C-language library commands and the driver calls supported by the Controller Link Support Board.

5-1	Library Commands and Driver Call List .....
5-2	C Commands .....
5-2-1	DRIVER OPEN — clkopen .....
5-2-2	DRIVER CLOSE — clkclose .....
5-2-3	MESSAGE SEND — clksend .....
5-2-4	MESSAGE RECEIVE — clkrecv .....
5-2-5	MESSAGE RECEIVE WAIT — clkrcvw .....
5-2-6	DATA LINK READ — clkread .....
5-2-7	DATA LINK WRITE — clkwrite .....
5-2-8	STATUS READ — clkstatrd .....
5-2-9	NETWORK ADD/REMOVE — clkcmd .....
5-2-10	DATA LINK READ 2 — clkread2 .....
5-2-11	DATA LINK WRITE 2 — clkwrite2 .....
5-3	Driver Calls .....
5-3-1	INITIALIZE — 00 Hex .....
5-3-2	MESSAGE SEND — 01 Hex .....
5-3-3	MESSAGE RECEIVE — 02 Hex .....
5-3-4	DATA LINK READ — 03 Hex .....
5-3-5	DATA LINK WRITE — 04 Hex .....
5-3-6	STATUS READ — 05 Hex .....
5-3-7	NETWORK ADD/REMOVE — 07 Hex .....
5-3-8	DATA LINK READ 2 — 20 Hex .....
5-3-9	DATA LINK WRITE 2 — 21 Hex .....

## 5-1 Library Commands and Driver Call List

Function	C-library commands	Driver call codes
Initialize	---	00 Hex
Opens the Controller Link driver and adds the Support Board to the network.	<i>clkopen</i>	---
Closes the Controller Link driver and removes the Support Board from the network.	<i>clkclose</i>	---
Transmits a message or FINS command.	<i>clksend</i>	01 Hex
Receives a message or FINS command.	<i>clkrecv</i>	02 Hex
Receives a message or FINS command. The time that the Support Board waits for the message can be specified with this command.	<i>clkrcvw</i>	
Reads data from the data link area (with data link cache).	<i>clkread</i>	03 Hex
Writes data to the data link area (with data link cache).	<i>clkwrite</i>	04 Hex
Checks the operational status of the Support Board.	<i>clkstatrd</i>	05 Hex
Adds/removes the Support Board to/from the network.	<i>clkcmd</i>	07 Hex
Reads data from the data link area (without data link cache).	<i>clkread2</i>	20 Hex
Writes data to the data link area (without data link cache).	<i>clkwrite2</i>	21 Hex

## 5-2 C Commands

The following table shows the commands in the C library. Refer to *Section 4 Creating Applications* for details on using the C library.

Command	Function	Page
<i>clkopen</i>	Opens the Controller Link driver and adds the Support Board to the network.	73
<i>clkclose</i>	Closes the Controller Link driver and removes the Support Board from the network.	73
<i>clksend</i>	Transmits a message or FINS command.	73
<i>clkrecv</i>	Receives a message or FINS command.	75
<i>clkrcvw</i>	Receives a message or FINS command. The time that the Support Board waits for the message can be specified with this command.	77
<i>clkread</i>	Reads data from the data link area (with data link cache).	79
<i>clkwrite</i>	Writes data to the data link area (with data link cache).	80
<i>clkstatrd</i>	Checks the operational status of the Support Board.	81
<i>clkcmd</i>	Adds/removes the Support Board to/from the network.	83
<i>clkread2</i>	Reads data from the data link area (without data link cache).	83
<i>clkwrite2</i>	Writes data to the data link area (without data link cache).	85

### 5-2-1 DRIVER OPEN — *clkopen*

The *clkopen* command opens the Controller Link driver and adds the Support Board to the network. Other C commands in the library can be executed after the *clkopen* command has been executed.

Use the *clkclose* command to close the device driver and remove the Support Board from the network.

The *clkcmd* command can also be used to add/remove the Support Board to/from the network. Other C commands can still be executed when the *clkcmd* command has been used to remove the Support Board from the network.

**Note** It is necessary to open the Controller Link driver even if communications will not be conducted with other nodes in the network.

#### Command Syntax

```
int clkopen()
```

#### Parameters

None

#### Responses

The following table shows the possible responses when *clkopen* is executed.

Response	Meaning
0	The command was executed normally.
-3	The Support Board's driver was already open.
-10	A system call error occurred.
-16	A Support Board error occurred.

#### Related Commands

*clkclose()*, *clkcmd()*

### 5-2-2 DRIVER CLOSE — *clkclose*

The *clkclose* command closes the Controller Link driver and removes the Support Board from the network. Other C commands cannot be executed when the Support Board has been removed from the network by the *clkclose* command. Use the *clkcmd* command to remove the Support Board from the network but still allow other C commands to be executed.

Use the *clkopen* command to open the Support Board's device driver and add it to the network.

If the Controller Link driver is closed while data links are active, the Controller Link Support Board data links will stop automatically.

**Note**

1. Close the Controller Link driver before exiting application programs.
2. When the Controller Link Support Board is acting as the polling node and data links are active, wait 3 seconds after closing the driver using the *clkclose* command before opening it with the *clkopen* command.

#### Command Syntax

```
int clkclose()
```

#### Parameters

None

#### Responses

The following table shows the possible responses when *clkclose* is executed.

Response	Meaning
0	The command was executed normally.
-2	The Support Board's driver was not open.
-16	A Support Board error has occurred.

#### Related Commands

*clkopen()*, *clkcmd()*

### 5-2-3 MESSAGE SEND — *clksend*

The *clksend* command is used to send FINS commands and responses. A response is automatically returned to commands addressed to the Support Board, but not to commands addressed to the computer.

When returning responses to FINS commands received by the host computer's program through the Support Board, set the *type* parameter to 1 to indicate a



response. Refer to *Section 7 Message Service* for details on FINS commands and responses.

The destination information and command/response data are specified in the structure of *clkio*.

**Note** The FINS command or response will not be sent when the command is executed in the program, but when the Support Board receives the token, giving it the right to send.

### Command Syntax

```
int clksend(sndbuf, nbyte)
```

```
struct      clkio *sndbuf;
unsigned int nbyte;

struct  clkio{
    unsigned int  type;
    unsigned int  sid;
    unsigned int  netadr;
    unsigned int  nodeadr;
    unsigned int  unitadr;
    unsigned char *text;
};
```

### Parameters

The parameters for the *clksend* command are described in the following table.

Parameter	Type	IN/OUT	Function
sndbuf	Structure	IN	Pointer to structure of <i>clkio</i>
nbyte	Integer (2 to 2,002)	IN	Indicates the number of bytes of data (from the FINS command or response code to the end code) being transmitted. Up to 2,002 bytes can be transmitted.
type	Integer (0, 1, or 2)	IN	Indicates the type of transmission, as shown below: 0: Command, response required 1: Response 2: Command, response not required
sid	Integer (0 to 255)	IN	The "service ID number;" can be used to identify the process which is the source of the transmission.
netadr	Integer (0 to 127)	IN	Specifies the destination network address. 0: Local network
nodeadr	Integer (0 to 126, or 255)	IN	Specifies the destination node address. 0: Local Controller Link Support Board 1 to 32: Node on a Controller Link Network 1 to 62: Node on a SYSMAC LINK Network 1 to 126: Node on a SYSMAC NET Network 255: Broadcast transmission
unitadr	Integer	IN	Indicates the destination unit address. 16 to 31: Controller Link Support Board (16 to 31: Board with unit numbers 0 to 15) or CPU Bus Unit. 254: The Board or Unit connected to the network. 1: Computer's user program 0: PC's CPU Unit
text	Character string	IN	The data to be transmitted (from the FINS command or response code to the end code). Each byte can be from 0 to 255 (00 to FF in hexadecimal). One byte of FINS command/response data corresponds to one character.

**Note** 1. When a command requiring a response is sent and the *type* parameter is set to 0, either the *clkrcv* or *clkrcvw* command must be used to receive the response.

2. This command can be used not only to send FINS commands but also to send responses when FINS commands are received by the user program (set the *type* parameter to 1.)
3. When sending a response, be sure to attach the end code and a service ID (*sid*) that is the same as the command service ID (*sid*.)

## Responses

The following table shows the possible responses when *clksend* is executed.

Response	Meaning
0	The command was executed normally.
-1	Parameter error.
-4	The Support Board is not in the network.
-7	Transmission timeout.
-8	The Support Board is busy. (One of the communication buffers is full.)
-10	A system call error occurred.
-16	A Support Board error has occurred.

## Related Commands

*clkrecv()*, *clkrcvw()*

### 5-2-4 MESSAGE RECEIVE — *clkrecv*

The *clkrecv* command is used to read FINS commands and responses received in the reception buffer of the Controller Link Support Board or driver and store the data according to the parameters. If the reception buffer is empty, the Support Board waits until data is received and all other processes will be stopped while waiting. The command can be cancelled by pressing the Escape Key (Esc).

```
int clkrecv(rcvbuf, nbyte)
```

```

struct      clkio *rcvbuf;
unsigned int  nbyte;

struct  clkio{
    unsigned int  type;
    unsigned int  sid;
    unsigned int  netadr;
    unsigned int  nodeadr;
    unsigned int  unitadr;
    unsigned char *text;
};

```

## Command Syntax

### Parameters

The parameters for the *clkrecv* command are described in the following table.

Parameter	Type	IN/OUT	Function
<i>rcvbuf</i>	Structure	IN	Pointer to structure of <i>clkio</i>
<i>nbyte</i>	Integer (2 to 2,002)	IN	Indicates the number of bytes of data that will be read from the reception buffer to text. Up to 2,002 bytes can be read.
<i>type</i>	Integer (0, 1, or 2)	OUT	Indicates the type of transmission, as shown below: 0: Command, response required 1: Response 2: Command, response not required
<i>sid</i>	Integer (0 to 255)	OUT	The "service ID number;" can be used to identify the process which is the source of the transmission.
<i>netadr</i>	Integer (0 to 127)	OUT	Specifies the source network address. 0: Local network

Parameter	Type	IN/OUT	Function
nodeadr	Integer (0 to 126)	OUT	Specifies the source node address. 0: Local Controller Link Support Board 1 to 32: Node on a Controller Link Network 1 to 62: Node on a SYSMAC LINK Network 1 to 126: Node on a SYSMAC NET Network
unitadr	Integer	OUT	Indicates the source unit address. 16 to 31: Controller Link Support Board (16 to 31: Board with unit numbers 0 to 15) or CPU Bus Unit. 254: The Board or Unit connected to the network. 1: Computer program 0: PC's CPU Unit
text	Character string	OUT	The data read from the Support Board's reception buffer. The buffer contains the data from the FINS command/response code to the end code. Each byte can be from 0 to 255 (00 to FF in hexadecimal). One byte of FINS command/response data corresponds to one character.

### Description

Two commands are provided to read data from the reception buffer, *clkrecv* and *clkrcvw*. The commands operate differently if the reception buffer is empty.

- 1, 2, 3...**
1. If the reception buffer is empty when *clkrecv* is executed, the computer will be put on standby until data is received or the Esc Key is pressed. No other processes will be executed while the computer is on standby.
  2. If the reception buffer is empty when *clkrcvw* is executed, the computer will be put on standby until data is received or a specified time elapses. No other processes will be executed while the computer is on standby.

When the *clkrecv* command is executed, the number of bytes of data specified by the *nbyte* parameter will be read from the reception buffer and stored in *text*. The source information and command/response data are stored in the structure of *clkio*.

If the number of bytes specified by *nbyte* is greater than the number of bytes of data in the buffer, all of the data in the buffer will be read. If the number of bytes of data in the buffer is greater than *nbyte*, only *nbyte* bytes of data will be read from the buffer; the remaining data will be lost. When *clkrecv* is completed normally, the response will indicate the actual number of bytes received in the buffer, regardless of the value of *nbyte*.

- Note**
1. Before using the *clkrecv* command, be sure to allocate *nbyte* bytes of memory to *text*.
  2. Use the *clkrecv* or *clkrcvw* commands as often as possible to read data from the reception buffer. If the reception buffer fills up, more data cannot be received.
  3. Refer to *Section 7 Message Service* for details on FINS commands and responses.
  4. The size of the reception buffer is specified using the /B option when installing the Controller Link driver. The default reception buffer size is 2,014 × 2 bytes.

## Responses

The following table shows the possible responses when *clkrcv* is executed.

Response	Meaning
Positive number	The number of bytes of data received in the reception buffer. (The command was executed normally.)
-1	Parameter error.
-10	A system call error occurred.
-16	A Support Board error has occurred.
-27	The command was cancelled by pressing the Esc Key.

## Related Commands

*clksend()*, *clkrcvw()*

### 5-2-5 MESSAGE RECEIVE WAIT — *clkrcvw*

The *clkrcvw* command is used to read FINS commands and responses received in the reception buffer of the Controller Link Support Board or driver and store the data according to the parameters. If the reception buffer is empty, the Support Board waits until data is received or the specified time elapses. All other processes will be stopped while waiting.

## Command Syntax

```
int clkrcvw(rcvbuf, nbyte, time)
```

```

struct      clkio *rcvbuf;
unsigned int nbyte;
int         time;

struct  clkio{
    unsigned int  type;
    unsigned int  sid;
    unsigned int  netadr;
    unsigned int  nodeadr;
    unsigned int  unitadr;
    unsigned char *text;
};

```

## Parameters

The parameters for the *clkrcvw* command are described in the following table.

Parameter	Type	IN/OUT	Function
rcvbuf	Structure	IN	Pointer to structure of <i>clkio</i>
nbyte	Integer (2 to 2002)	IN	Indicates the number of bytes of data that will be read from the reception buffer to text. Up to 2002 bytes can be read.
time	Integer (0 to 255)	IN	Specifies the time that the computer will standby when the reception buffer is empty. The time is set in 0.1 s units (0 to 25.5 s).
type	Integer (0, 1, or 2)	OUT	Indicates the type of transmission, as shown below: 0: Command, response required 1: Response 2: Command, response not required
sid	Integer (0 to 255)	OUT	The "service ID number;" can be used to identify the process which is the source of the transmission.
netadr	Integer (0 to 127)	OUT	Specifies the source network address. 0: Local network
nodeadr	Integer (0 to 126)	OUT	Specifies the source node address. 0: Local Controller Link Support Board 1 to 32: Node on a Controller Link Network 1 to 62: Node on a SYSMAC LINK Network 1 to 126: Node on a SYSMAC NET Network

Parameter	Type	IN/OUT	Function
unitadr	Integer	OUT	Indicates the source unit address. 16 to 31: Controller Link Support Board (16 to 31: Board with unit numbers 0 to 15) or CPU Bus Unit. 254: The Board or Unit connected to the network. 1: Computer 's user program 0: PC's CPU Unit
text	Character string	OUT	The data read from the Support Board's reception buffer. The buffer contains the data from the FINS command/response code to the end code. Each byte can be from 0 to 255 (00 to FF in hexadecimal). One byte of FINS command/response data corresponds to one character.

**Description**

Two commands are provided to read data from the reception buffer, *clkrecv* and *clkrcvw*. The commands operate differently if the reception buffer is empty.

- 1, 2, 3...**
1. If the reception buffer is empty when *clkrecv* is executed, the computer will be put on standby until data is received or the Esc Key is pressed. No other processes will be executed while the computer is on standby.
  2. If the reception buffer is empty when *clkrcvw* is executed, the computer will be put on standby until data is received or a specified time elapses. No other processes will be executed while the computer is on standby.

When the *clkrcvw* command is executed, the number of bytes of data specified by the *nbyte* parameter will be read from the reception buffer and stored in *text*. The source information and command/response data are stored in the structure of *clkio*.

If the number of bytes specified by *nbyte* is greater than the number of bytes of data in the buffer, all of the data in the buffer will be read. If the number of bytes of data in the buffer is greater than *nbyte*, only *nbyte* bytes of data will be read from the buffer; the remaining data will be lost. When *clkrcvw* is completed normally, the response will indicate the actual number of bytes received in the buffer, regardless of the value of *nbyte*.

- Note**
1. Before using the *clkrcvw* command, be sure to allocate *nbyte* bytes of memory to *text*.
  2. Use the *clkrecv* or *clkrcvw* commands as often as possible to read data from the reception buffer. If the reception buffer fills up, more data cannot be received.
  3. Refer to *Section 7 Message Service* for details on FINS commands and responses.
  4. The size of the reception buffer is specified using the /B option when installing the Controller Link driver. The default reception buffer size is 2,014 × 2 bytes.

**Responses**

The following table shows the possible responses when *clkrcvw* is executed.

Response	Meaning
Positive number	The number of bytes of data received in the reception buffer. (The command was executed normally.)
-1	Parameter error.
-10	A system call error occurred.
-16	A Support Board error has occurred.
-25	The command was cancelled when the specified time elapsed.
-26	The command was cancelled because the reception buffer was empty. (This response is returned only when the <i>time</i> parameter is set to 0.)

**Related Commands**

*clksend()*, *clkrecv()*

### 5-2-6 DATA LINK READ — *clkread*

The *clkread* command is used to read data from a data link area. This command can be used only when a data link cache has been set using the Controller Link BIOS option.

**Command Syntax**                    `int clkread(linkbuf, size, offset)`

```

        unsigned char *linkbuf;
        unsigned int  size;
        unsigned int  offset;
    
```

**Parameters**                        The parameters for the *clkread* command are described in the following table.

Parameter	Type	IN/OUT	Function
linkbuf	Character string	OUT	Indicates the area where the data link data is stored. Data can be from 0 to 255; two bytes equal one word.
size	Integer (2 to 64,000)	IN	Indicates the number of bytes of data that will be read. Even numbered bytes from 2 to 64,000 Maximum No. of link words: 32,000
offset	Integer (0 to 63,998)	IN	Indicates the offset from the beginning of the data link area. This parameter specifies the beginning address from which data will be read.

**Description**                        When the *clkread* command is executed, the number of bytes of data specified by the *size* parameter will be read from the data link area beginning at the address specified by the *offset* parameter and stored in the memory area specified by the *linkbuf* parameter.

In the example below, the *m* words of the data link area allocated to node 3 are read. There are *n* words allocated to nodes 1 and 2, so the *offset* parameter is set to  $2 \times n$  bytes. All *m* words will be read, so the *size* parameter is set to  $2 \times m$  bytes.

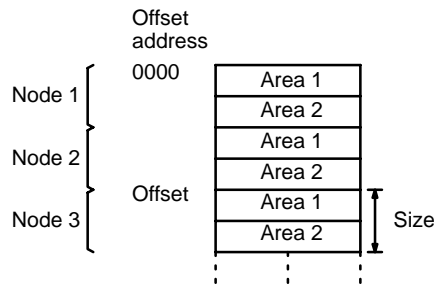

Even-numbered bytes correspond to the leftmost byte of words, and odd-numbered bytes correspond to the rightmost byte of words, as shown below.

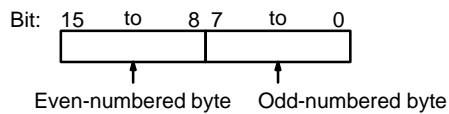

- Note**
1. Before using the *clkread* command, be sure to allocate the number of bytes of memory specified by the *size* parameter to *linkbuf*.
  2. If a data link cache has not been specified using the Controller Link BIOS option in the CONFIG.SYS file, an error will occur (command cannot be executed.)
  3. The concurrence of the data link data from one node is guaranteed (all the data for that node will have been read at the same time). Concurrence cannot be guaranteed for data link data between different nodes.

Responses

The following table shows the possible responses when *clkread* is executed.

Response	Meaning
0	The command was executed normally.
-1	Parameter error.
-10	A system call error occurred.
-11	Command could not be executed.
-16	A Support Board error has occurred.

Related Commands

*clkwrite()*

### 5-2-7 DATA LINK WRITE — *clkwrite*

The *clkwrite* command is used to write data to a data link area. This command can be used only when a data link cache has been set using the Controller Link BIOS option.

Command Syntax

```
int clkwrite(wlinkbuf, size, offset)
```

```
    unsigned char *wlinkbuf;
    unsigned int  size;
    unsigned int  offset;
```

Parameters

The parameters for the *clkwrite* command are described in the following table.

Parameter	Type	IN/OUT	Function
wlinkbuf	Character string	IN	Indicates the area where the data link data is stored. Data can be from 0 to 255; two bytes equal one word.
size	Integer (2 to 64,000)	IN	Indicates the number of bytes of data that will be written. Up to 64,000 bytes (32,000 words) can be written.
offset	Integer (0 to 63,998)	IN	Indicates the offset from the beginning of the data link area. This parameter specifies the beginning address to which data will be written.

Description

When the *clkwrite* command is executed, the number of bytes of data specified by the *size* parameter will be read from the memory area specified by the *wlinkbuf* parameter and written to the data link area beginning at the address specified by the *offset* parameter.

In the example below, data from the *wlinkbuf* area is written to the *m* words of the data link area allocated to the Support Board (node 3). There are *n* words allocated to nodes 1 and 2, so the *offset* parameter is set to  $2 \times n$  bytes. All *m* words will be written, so the *size* parameter is set to  $2 \times m$  bytes.

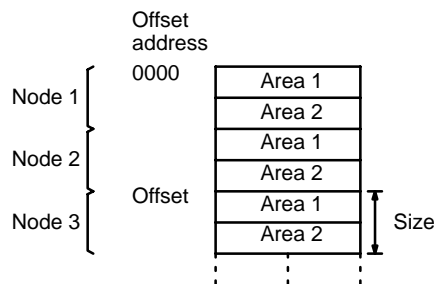

Even-numbered bytes correspond to the leftmost byte of words, and odd-numbered bytes correspond to the rightmost byte of words, as shown below.

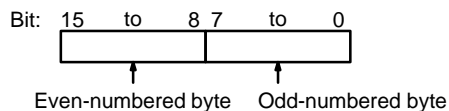

- Note**
1. Data should be written only to the send area of the data link area allocated to the Support Board.
  2. If a data link cache has not been set using the Controller Link BIOS option in the CONFIG.SYS file, an error will occur (command cannot be executed.)
  3. The concurrence of the data link data from one node is guaranteed (all the data for that node will be written at the same time).

**Responses**

The following table shows the possible responses when *clkwrite* is executed.

Response	Meaning
0	The command was executed normally.
-1	Parameter error.
-10	A system call error occurred.
-11	Command could not be executed.
-16	A Support Board error has occurred.

**Related Commands**

*clkread()*

**5-2-8 STATUS READ — *clkstatrd***

The *clkstatrd* command is used to read the operational status of the Controller Link Support Board.

**Command Syntax**

```
int clkstatrd(rcvbuf, nbyte)
```

```
    unsigned char *rcvbuf;
    unsigned int  nbyte;
```

**Parameters**

The parameters for the *clkstatrd* command are described in the following table.

Parameter	Type	IN/OUT	Function
rcvbuf	Character string	OUT	Indicates the area where the operational status data is stored. Data can be from 0 to FF Hex.
nbyte	Integer (1 to 68)	IN	Indicates the number of bytes of data read. Up to 68 bytes can be read.

When the *clkstatrd* command is executed, the number of bytes of status data specified by the *nbyte* parameter will be written to the memory area specified by



the *rcvbuf* parameter. The structure of the operational status data is shown below.

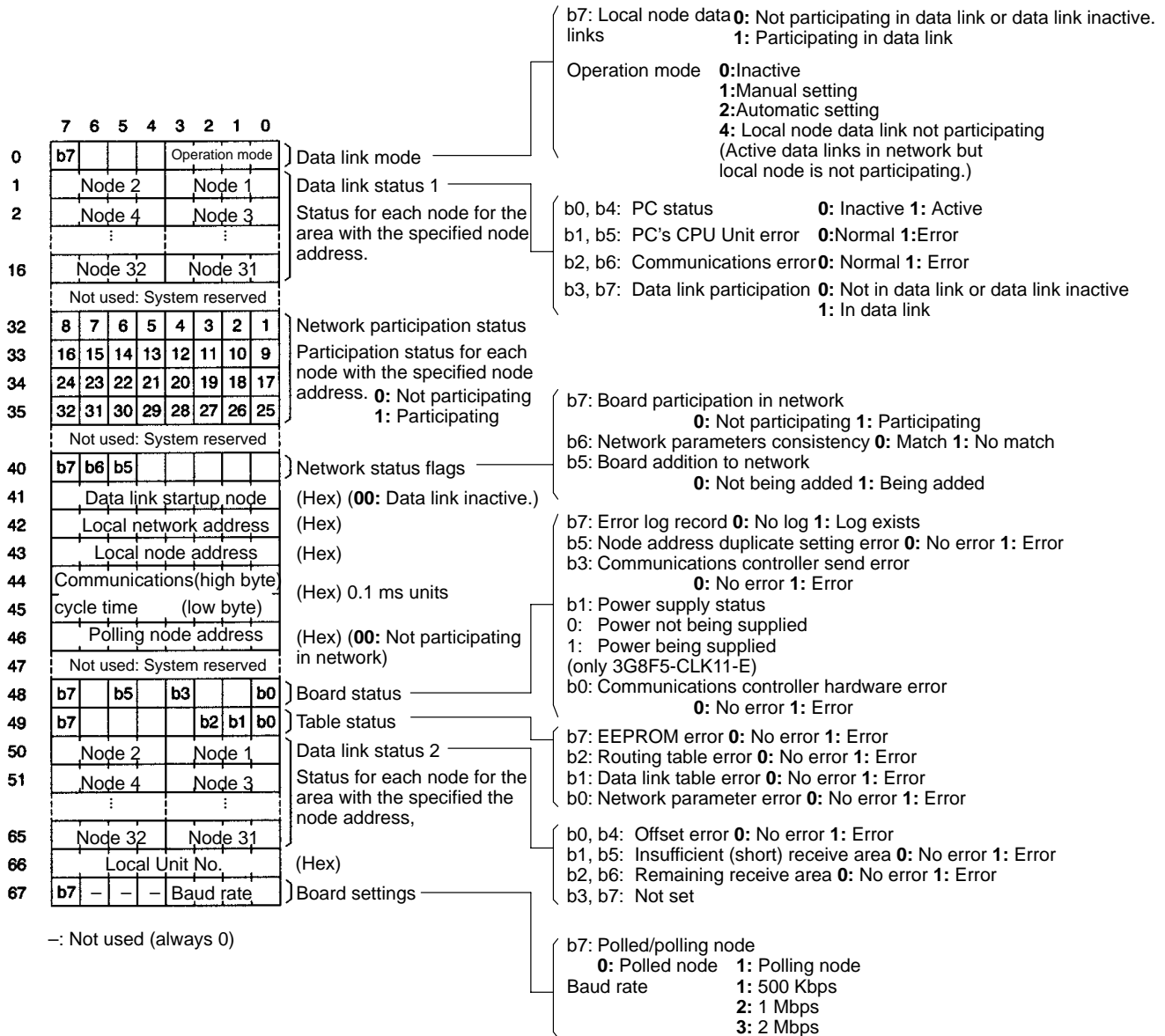

- Note**
1. Before using the *clkstatrd* command, be sure to allocate *nbyte* bytes of memory to *rcvbuf*.
  2. Data link status 1 and data link status 2 are valid only when the local node is participating in the data links.
  3. For all Controller Link Support Board nodes, the following status will always exist in data link status 1.  
PC operation: 1 (active) and PC error: 0 (normal).

Response	Meaning
0	The command was executed normally.
-1	Parameter error.
-10	A system call error occurred.
-16	A Support Board error has occurred.

## 5-2-9 NETWORK ADD/REMOVE — *clkcmd*

The *clkcmd* command is used to add the Support Board to the Network or remove it from the Network. Unlike the *clkopen* and *clkclose* commands, *clkcmd* does not open or close the Controller Link driver, it operates only when the Controller Link driver is already open.

When the Support Board is removed from the network with the *clkclose* command, the driver is closed and other commands from the C library cannot be used. When the Support Board is removed from the network with the *clkcmd* command, however, the driver remains open and other commands from the C library can still be used.

If the Support Board is removed while data links are active, the Controller Link Support Board's data links will stop.

- Note**
1. The *clkcmd* command cannot open the Controller Link driver, the driver must be opened with the *clkopen* command beforehand.
  2. When the Controller Link Support Board is acting as the polling node and data links are active, wait 3 seconds after leaving the network before adding the Board to the network again.

### Command Syntax

```
int clkcmd(cmd)
```

```
int cmd;
```

### Parameters

The parameter for the *clkcmd* command is described in the following table.

Parameter	Type	IN/OUT	Function
cmd	Integer (0 or 1)	IN	Indicates whether to add the Support Board to the network or remove it from the network. 0: Add Support Board to network. 1: Remove Support Board from network.

### Responses

The following table shows the possible responses when *clkcmd* is executed.

Response	Meaning
0	The command was executed normally.
-1	Parameter error.
-10	A system call error occurred.
-16	A Support Board error has occurred.

### Related Commands

*clkopen()*, *clkclose()*

## 5-2-10 DATA LINK READ 2 — *clkread2*

The *clkread2* command is used to read data from a data link area at the specified node address. The *clkread2* command can be used only when a data link cache has **not** been set using the Controller Link BIOS option.

### Command Syntax

```
int clkread2(linkbuf, size, offset)
```

```
unsigned char *linkbuf;
unsigned int size;
unsigned int offset;
unsigned int node;
```

Parameters

The parameters for the *clkread* command are described in the following table.

Parameter	Type	IN/OUT	Function
linkbuf	Character string	OUT	Indicates the area where the data link data is stored. Data can be from 0 to FF Hex; two bytes equal one word.
size	Integer (2 to 2,000)	IN	Indicates the number of bytes of data that will be read. Even numbered bytes from 2 to 2,000 Maximum No. of link words: 1,000
offset	Integer (0 to 1,998)	IN	Indicates the offset from the beginning of the data link area. This parameter specifies the beginning address from which data will be read.
node	Integer (1 to 32)	IN	Indicates the read node address.

Description

When the *clkread* command is executed, the number of bytes of data specified by the *size* parameter will be read from the data link area beginning at the address specified by the *offset* parameter and stored in the memory area specified by the *linkbuf* parameter.

In the example below, the *m* words of the data link area allocated to node 3 are read. There are *n* words allocated to nodes 1 and 2, so the *offset* parameter is set to  $2 \times n$  bytes. All *m* words will be read, so the *size* parameter is set to  $2 \times m$  bytes.

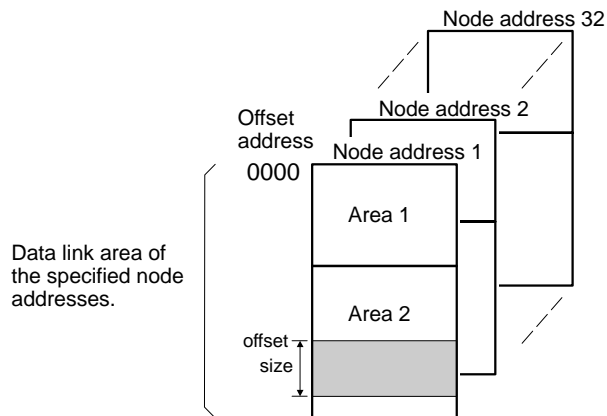

Even-numbered bytes correspond to the leftmost byte of words, and odd-numbered bytes correspond to the rightmost byte of words, as shown below.

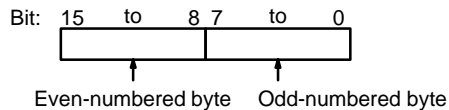

- Note**
1. Before using the *clkread* command, be sure to allocate the number of bytes of memory specified by the *size* parameter to *linkbuf*.
  2. If a data link cache has been set using the Controller Link BIOS option in the CONFIG.SYS file, an error will occur (command cannot be executed.)
  3. You cannot read only part of receive data using this command in one reception and then read the rest of the receive data in the next reception. You must read all the desired data at the same time.
  4. The concurrence of the data link data from one node is guaranteed (all the data for that node will have been read at the same time). Concurrence cannot be guaranteed for data link data between different nodes.

## Responses

The following table shows the possible responses when *clkread* is executed.

Response	Meaning
0	The command was executed normally.
-1	Parameter error.
-10	A system call error occurred.
-11	Command could not be executed.
-16	A Support Board error has occurred.
-26	No receive data

## Related Commands

*clkwrite2()*

### 5-2-11 DATA LINK WRITE 2 — *clkwrite2*

The *clkwrite2* command is used to write data to a data link area. This command can be used only when a data link cache has **not** been set using the Controller Link BIOS option.

## Command Syntax

```
int clkwrite2(wlinkbuf, size, offset)
```

```
    unsigned char *wlinkbuf;
    unsigned int  size;
    unsigned int  offset;
    unsigned int  node;
```

## Parameters

The parameters for the *clkwrite* command are described in the following table.

Parameter	Type	IN/OUT	Function
wlinkbuf	Character string	IN	Indicates the area where the data link data is stored. Data can be from 0 to FF Hex; two bytes equal one word.
size	Integer (2 to 2,000)	IN	Indicates the number of bytes of data that will be written. Even numbered bytes from 2 to 2,000 Maximum No. of send words per node :1,000
offset	Integer (0 to 1,998)	IN	Indicates the offset from the beginning of the data link area. This parameter specifies the beginning address from which data will be written.
node	Integer (1 to 32)	IN	Indicates the read node address.

## Description

When the *clkwrite* command is executed, the number of bytes of data specified by the *size* parameter will be read from the memory area specified by the *wlinkbuf* parameter and written to the data link area beginning at the address specified by the *offset* parameter.

In the example below, data from the *wlinkbuf* area is written to the m words of the data link area allocated to the Support Board (node 3). There are n words allo-

cated to nodes 1 and 2, so the *offset* parameter is set to  $2 \times n$  bytes. All *m* words will be written, so the *size* parameter is set to  $2 \times m$  bytes.

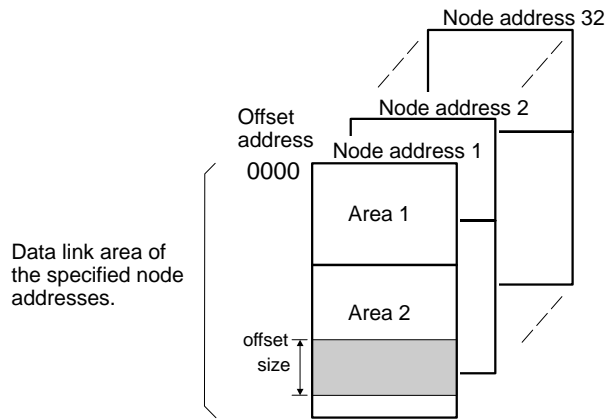

Even-numbered bytes correspond to the leftmost byte of words, and odd-numbered bytes correspond to the rightmost byte of words, as shown below.

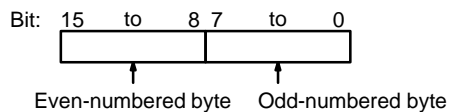

- Note**
1. Data should be written only to the send area allocated to the Support Board.
  2. If a data link cache has been set using the Controller Link BIOS option in the CONFIG.SYS file, an error will occur (command cannot be executed.)
  3. The maximum data link area (send area) for each node is 2,000 bytes. Do not exceed this limit when writing data.
  4. The concurrence of the data link data from one node is guaranteed (all the data for that node will have been read at the same time).

**Responses**

The following table shows the possible responses when *clkwrite* is executed.

Response	Meaning
0	The command was executed normally.
-1	Parameter error.
-10	A system call error occurred.
-11	The command could not be executed.
-16	A Support Board error has occurred.

**Related Commands**

*clkread2()*

## 5-3 Driver Calls

This section describes driver calls which don't use library files.

The following table shows the driver calls that can be made for the Controller Link Support Board. Refer to *Section 4 Creating Applications* for details on driver calls

Driver call	Function code	Page
Initializes the Support Board.	00 Hex	87
Transmits a message.	01 Hex	88
Receives a message.	02 Hex	90
Reads data from a data link area (with cache).	03 Hex	92
Writes data to a data link area (with cache).	04 Hex	94
Checks the operational status of the Support Board.	05 Hex	96
Adds/removes the Support Board to/from the network.	07 Hex	98
Reads data from a data link area (without cache).	20 Hex	98
Writes data to a data link area (without cache).	21 Hex	100

### 5-3-1 INITIALIZE — 00 Hex

The INITIALIZE (00 Hex) driver call prepares the Support Board so that it is able to receive FINS commands and responses. The call needs to be made only once when starting up the Controller Link Support Board.

**Note** When using driver calls for the Controller Link Support Board, initialize the Board with this function before using other functions.

#### Call Procedure

AX ← 4403 Hex

BX ← File handle (the return value when a file is opened)

CX ← 0002 Hex (Total number of bytes in user command packet)

DS:DX ← The first address storing the command packet (segment:offset)

INT 21 Hex

#### User Command Packet

Offset: Bytes	Content	
+0	00 Hex (function code)	IN
+1	Response	OUT

#### Parameters

Parameter	Meaning
Function code	00 Hex (fixed)

#### Responses

The following table shows the possible responses when 20 Hex is executed.

Response	Meaning
00 Hex	The command was executed normally.
31 Hex	A Support Board error has occurred.

## 5-3-2 MESSAGE SEND — 01 Hex

The MESSAGE SEND (01 Hex) driver call is used to send FINS commands and responses. A response is automatically returned to commands addressed to the Support Board, but not to commands addressed to the computer. For further details on FINS commands and responses refer to *Section 7 Message Service*.

### Call Procedure

AX ← 4403 Hex  
 BX ← File handle (the return value when a file is opened)  
 CX ← 000E Hex (Total number of bytes in user command packet)  
 DS:DX ← The first address storing the command packet (segment:offset)  
 INT 21 Hex

### User Command Packet

Offset: Bytes	Content	
+0	00 Hex (function code)	IN
+1	Send area start address    Offset	(Low) IN
+2		(High) IN
+3	Send area start address    Segment	(Low) IN
+4		(High) IN
+5	Send area total No. of bytes	(Low) IN
+6		(High) IN
+7	Data type	IN
+8	Service ID	IN
+9	Destination network address	IN
+10	Destination node address	IN
+11	Destination unit address	IN
+12	00 Hex (System use only)	–
+13	Response	OUT

### Send Area

The send area contains all data (send area total No. of bytes) from the send area start address.

Offset: Bytes	Content	
+0	Send data	IN
+1	(FINS command/response command codes to the last data.)	IN
:		:
+n-1		IN

n: Send area total No. of bytes

### Parameters

The parameters for MESSAGE SEND (01 Hex) are described in the following table.

Parameter	Function
Function code	01 Hex (fixed)
Send area start address	Designate the send area start address as an offset.
Send area total No. of bytes	The data to be transmitted (from the FINS command/response code to the end code). Data must be from 0002 to 07D2 Hex (2 to 2002.)
Data type	Indicates the type of transmission, as shown below: 00 Hex: Command, response required 01 Hex: Command, response not required 40 Hex: Response

Parameter	Function
Service ID	The "service ID number;" can be used to identify the process which is the source of the transmission. 00 to FF Hex When sending a response, use the same service ID as for the command.
Destination network address	00 to 7F Hex (00 Hex: Local network)
Destination node address	00 Hex: Local Controller Link Support Board 01 to 20 Hex: Node on a Controller Link Network 01 to 3E Hex: Node on a SYSMAC LINK Network 01 to 7E Hex: Node on a SYSMAC NET Network FF Hex: Broadcast transmission
Destination unit address	Indicates the destination of the message. 00 Hex: CPU Unit 01 Hex : Computer (user program) 10 to 1F Hex: Controller Link Support Board (Board with Unit numbers 0 to 15.) CPU Bus Unit FE Hex: All Support Boards and Units on the network.
Send data	All data from the FINS command/response command code to the end code. 00 to FF Hex

**Description**

MESSAGE SEND (01 Hex) is used to send FINS commands and responses. The parameters contain the command/response data and indicate the destination node.

- Note**
1. When the data type is set to 00 Hex to require a response, be sure to use the MESSAGE RECEIVE (02 Hex) driver call to receive the response.
  2. This driver call is also used to return responses to FINS commands received by the user program through the Support Board (data type should be set to 40 Hex.).
  3. When sending responses, always attach an end code and the same service ID as the command service ID.
  4. This driver call is stored in the transmission buffer of the Controller Link Support Board and is not sent until the Support Board receives the token, giving it the right to transmit. For this reason, the send data is not sent until the driver call is executed and the Board has received the token.

**Responses**

The following table shows the possible responses when the MESSAGE SEND (01 Hex) driver call is executed.

Response	Meaning
00 Hex	The command was executed normally.
01 Hex	The Support Board is not in the network.
02 Hex	Transmission processing.
04 Hex	The Support Board is busy. (The buffer is full.)
11 Hex	Transmission timeout.
31 Hex	A Support Board error has occurred.
41 Hex	Parameter error.

**Related Commands**

MESSAGE RECEIVE (02 Hex)



### 5-3-3 MESSAGE RECEIVE — 02 Hex

The MESSAGE RECEIVE (02 Hex) driver call is used to read FINS commands and responses received in the reception buffer and store the data according to the parameters. You can specify whether or not to wait when there is no receive data to read. If waiting is specified, receive data will be waited for until received or until the specified receive waiting time has passed. If waiting is not specified, the call will end immediately when there is no receive data.

#### Call Procedure

AX ← 4403 Hex  
 BX ← File handle (the return value when a file is opened)  
 CX ← 0011 Hex (Total number of bytes in user command packet)  
 DS:DX ← The first address storing the command packet (segment:offset)  
 INT 21 Hex

#### User Command Packet

Offset: Bytes	Content	
+0	02 Hex (function code)	IN
+1	Receive waiting mode	IN
+2	Receive area start addressOffset	(Low) IN
+3		(High) IN
+4	Receive area start addressSegment	(Low) IN
+5		(High) IN
+6	Receive area total No. of bytes	(Low) IN
+7		(High) IN
+8	Receive waiting time	IN
+9	Response	OUT
+10	Data type	OUT
+11	Service ID	OUT
+12	Source network address	OUT
+13	Source node address	OUT
+14	Source unit address	OUT
+15	No. of bytes received	(Low) OUT
+16		(High) OUT

#### Receive Area

The receive area contains all data (send area total No. of bytes) from the receive area start address.

Offset: Bytes	Content	
+0	Receive data	OUT
+1	(FINS command/response command codes to the last data.)	OUT
:		OUT
+n-1		OUT

n: Receive area total No. of bytes

## Parameters

The parameters for MESSAGE RECEIVE (02 Hex) are described in the following table.

Parameter	Function
Function code	02 Hex (fixed)
Receive waiting mode	Designates whether or not to wait to receive data. 00 Hex: No waiting (Completes operations without waiting to receive data.) 01 Hex: Waiting (Receives data for the "receive waiting time.")
Receive area start address	Designates the receive area start address as an offset.
Receive area total No. of bytes	The data to be transmitted (from the FINS command or response code to the end code). Data must be from 0002 to 07D2 Hex (2 to 2002.)
Receive waiting time	00 to FF Hex (0.1 s units, 0 to 25.5 seconds.)
Data type	Indicates the type of receive data, as shown below: 00 Hex: Command, response required 01 Hex: Command, response not required 40 Hex: Response
Service ID	The "service ID number;" can be used to identify the process which is the source of the transmission. 00 to FF Hex When sending a response, use the same service ID as the command.
Source network address	00 to 7F Hex (00 Hex: Local network)
Source node address	01 to 20 Hex: Node on the Controller Link Network 01 to 3E Hex: Node on the SYSMAC LINK Network 01 to 7E Hex: Node on the SYSMAC NET Network FF Hex: Broadcast transmission
Source unit address	00 Hex: CPU Unit 01 Hex: Computer (user program) 10 to 1F Hex: Controller Link Support Board (Board with Unit numbers 0 to 15.) CPU Bus Unit FE Hex: All Support Boards and Units in network
Receive data No. of bytes	All actual data received by the Controller Link Support Board. 0002 to 07D2 Hex (2 to 2002)
Receive data	All data from the FINS command/response command code to the end code. 00 to FF Hex

## Description

When MESSAGE RECEIVE (02 Hex) is executed, data is read from the reception buffer and stored in the receive area and information on the source node is stored in the other parameters. Data is cleared from the buffer as it is stored in the receive area. The receive data No. of bytes parameter indicates the actual number of bytes of data (in binary) read from the buffer (regardless of the value of the receive area total No. of bytes).

If the actual number of bytes received is smaller than the receive area total No. of bytes, the number of bytes of data actually received will be stored in the receive area. If the actual number of bytes received is larger than the receive area total No. of bytes, the number of bytes specified in the receive area total No. of bytes will be stored in the receive area and all other bytes of data will be discarded. In either case the "receive data No. of bytes" shows the actual number of bytes of data received by the Controller Link Support Board.

- Note** 1. Before using MESSAGE RECEIVE (02 Hex), be sure to allocate enough memory for the "receive area No. of bytes."

2. Use MESSAGE RECEIVE (02 Hex) as often as possible to read data from the reception buffer. If the reception buffer fills up, more data cannot be received.
3. The size of the reception buffer is specified using the /B option when installing the Controller Link driver. The default reception buffer size is 2,014 × 2 bytes (including 12 × 2 bytes for headers).

### Responses

The following table shows the possible responses when MESSAGE RECEIVE (02 Hex) is executed.

Response	Meaning
00 Hex	The command was executed normally.
11 Hex	Command executed after the receive waiting time.
12 Hex	No receive data (No waiting time.)
31 Hex	A Support Board error has occurred.
41 Hex	Parameter error.

### Related Commands

MESSAGE RECEIVE (01 Hex)

## 5-3-4 DATA LINK READ — 03 Hex

The DATA LINK READ (03 Hex) driver call is used to read data from the data link area. DATA LINK READ (03 Hex) can be used only when a data link cache has been set using the Control Link BIOS option.

### Call Procedure

AX ← 4403 Hex

BX ← File handle (the return value when a file is opened)

CX ← 000A Hex (Total number of bytes in user command packet)

DS:DX ← The first address storing the command packet (segment:offset)

INT 21 Hex

### User Command Packet

Offset: Bytes	Content	
+0	03 Hex (function code)	IN
+1	Read start address (Low)	IN
+2	(High)	IN
+3	Read data storage address Offset (Low)	IN
+4	(High)	IN
+5	Read data storage address Segment (Low)	IN
+6	(High)	IN
+7	No. of bytes of data read (Low)	IN
+8	(High)	IN
+9	Response	OUT

**Read Data Storage Area**

The read data storage area contains all data (No. of bytes of data read) from the read data storage address.

Offset: Bytes	Content		
+0	Read data	Word data (bits 15 to 8)	OUT
+1		Word data (bits 7 to 0)	OUT
:			:
:			:
+n-2			OUT
+n-1			OUT

n: Total No. of bytes read.

**Parameters**

The parameters for 03 Hex are described in the following table.

Parameter	Function
Function code	03 Hex (fixed)
Read start address	Indicates the offset from the beginning of the data link area. This parameter specifies the beginning address from which data will be read.  Even numbered bytes 0000 to F9FE Hex (0 to 63998) If odd numbered bytes are specified, a parameter error will occur.
Read data storage address	Specifies the start address of the "read data storage address" using segment offset.
No. of bytes read	Even numbered bytes from 0002 to FA00 Hex (2 to 64,000.)  Maximum No. of link words: 32,000 words, 1 word of data per 2 bytes If an odd number of bytes is specified, a parameter error will occur.

**Description**

When DATA LINK READ (03 Hex) is executed, the number of bytes of data link data specified by the "No. of bytes read" parameter will be read from the data link area beginning at the address specified by the "read start address" parameter and stored in the read data storage area. If the data links are active, the data in the data link areas of other nodes will be present in the area.

In the example below, the m words of the data link area allocated to node 3 are read. There are n words allocated to nodes 1 and 2, so the "read start address" parameter is set to 2 × n bytes. All m words will be read, so the "read data storage" parameter is set to 2 × m bytes.

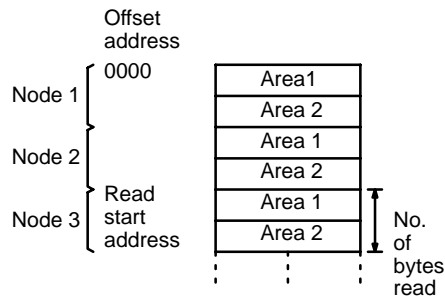

Even-numbered bytes correspond to the leftmost byte of words, and odd-numbered bytes correspond to the rightmost byte of words, as shown below.

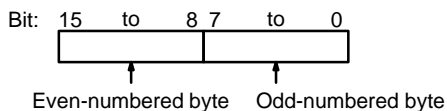

- Note**
1. Before using DATA LINK READ (03 Hex), be sure to allocate enough memory to the read data storage area.
  2. If a data link cache has not been set using the Controller Link BIOS option in the CONFIG.SYS file, an error will occur (command cannot be executed.)
  3. The concurrence of the data link data from one node is guaranteed (all the data for that node will have been read at the same time). Concurrence cannot be guaranteed for data link data between different nodes.

**Responses**

The following table shows the possible responses when CLKREAD is executed.

Response	Meaning
00 Hex	The command was executed normally.
31 Hex	A Support Board error has occurred.
32 Hex	Command cannot be executed.
41 Hex	Parameter error.

**Related Commands**

DATA LINK WRITE (04 Hex)

**5-3-5 DATA LINK WRITE — 04 Hex**

The DATA LINK WRITE (04 Hex) driver call is used to write data to the data link area. DATA LINK WRITE (04 Hex) can be used only when a data link cache has been set using the Controller Link BIOS option.

**Call Procedure**

- AX ← 4403 Hex
- BX ← File handle (the return value when a file is opened)
- CX ← 000A Hex (Total number of bytes in user command packet)
- DS:DX ← The first address storing the command packet (segment:offset)
- INT 21 Hex

**User Command Packet**

Offset: Bytes	Content	
+0	04 Hex (function code)	IN
+1	Write start address (Low)	IN
+2	(High)	IN
+3	Write data storage address Offset (Low)	IN
+4	(High)	IN
+5	Write data storage address Segment (Low)	IN
+6	(High)	IN
+7	No. of bytes of write data (Low)	IN
+8	(High)	IN
+9	Response	OUT

**Write Data Storage Area**

The write data storage area contains all data (No. of bytes of write data) from the write data storage address.

Offset: Bytes	Content	
+0	Write data Word data (bits 15 to 8)	OUT
+1	Word data (bits 7 to 0)	OUT
:		:
:		:
+n-2	Word data (bits 15 to 8)	OUT
+n-1	Word data (bits 7 to 0)	OUT

n: Total No. of bytes written.

**Parameters**

The parameters for DATA LINK WRITE (04 Hex) are described in the following table.

Parameter	Function
Function code	04 Hex (fixed)
Write start address	Indicates the offset from the beginning of the data link area. This parameter specifies the beginning address from which data will be written.  Even numbered bytes 0000 to F9FE Hex (0 to 63998)  If odd numbered bytes are specified, a parameter error will occur.
Write data storage address	Specifies the start address of the "write data storage address" as a segment offset.
No. of bytes written	Even numbered bytes from 0002 to FA00 Hex (2 to 64,000.)  Maximum No. of link words: 32,000 words, 1 word of data per 2 bytes.  If an odd number of bytes is specified, a parameter error will occur.

**Description**

When DATA LINK WRITE (04 Hex) is executed, the data in the write data storage area will be written to the data link area beginning at the address specified by the write start address parameter. If the data links are active, this data will be reflected in the data link areas of other nodes.

In the example below, data from the write data storage area is written to the m words of the data link area allocated to the Support Board (node 3). There are n words allocated to nodes 1 and 2, so the write start address parameter is set to 2 × n bytes. All m words will be written, so the No. of bytes written parameter is set to 2 × m bytes.

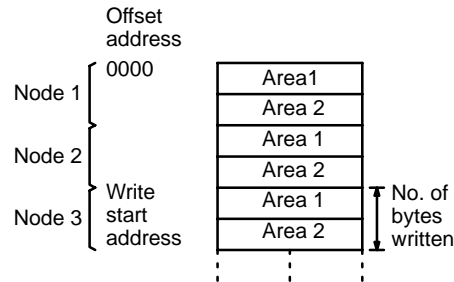

Even-numbered bytes correspond to the leftmost byte of words, and odd-numbered bytes correspond to the rightmost byte of words, as shown below.

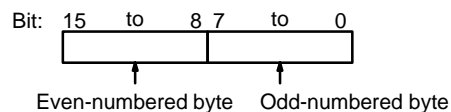

- Note**
1. Data should be written only to the send area of the data link area allocated to the Support Board.
  2. If a data link cache has not been set using the Controller Link BIOS option in the CONFIG.SYS file, an error will occur (command cannot be executed.)

**Responses**

The following table shows the possible responses when DATA LINK WRITE (04 Hex) is executed.

Response	Meaning
00 Hex	The command was executed normally.
31 Hex	A Support Board error has occurred.
32 Hex	Command cannot be executed.
41 Hex	Parameter error.

**Related Commands**

DATA LINK READ (03 Hex)

**5-3-6 STATUS READ — 05 Hex**

The STATUS READ (05 Hex) driver call is used to READ the operational status of the Support Board.

**Call Procedure**

AX ← 4403 Hex  
 BX ← File handle (the return value when a file is opened)  
 CX ← 0008 Hex (Total number of bytes in user command packet)  
 DS:DX ← The first address storing the command packet (segment:offset)  
 INT 21 Hex

**User Command Packet**

Offset: Bytes	Content	
+0	05 Hex (function code)	IN
+1	Status start address      Offset      (Low)	IN
+2		(High) IN
+3	Status start address      Segment      (Low)	IN
+4		(High) IN
+5	No. of bytes to read      (Low)	IN
+6		(High) IN
+7	Response	OUT

**Status Area**

The status area contains all data (No. of bytes of data read) from the status start address.

Offset: Bytes	Content	
+0	Status	IN
+1		IN
:		:
+n-1		IN

n: Total No. of bytes read.

**Parameters**

The parameters for STATUS READ (05 Hex) are described in the following table.

Parameter	Function
Function code	05 Hex (fixed)
Status start address	Specifies the start address of the "status address" using segment offset.
No. of bytes to read	0001 to 0044 Hex (1 to 68)

**Description**

When STATUS READ (05 Hex) is executed, the "No. of bytes to read" will be stored in the operational status area beginning from the status start address.

The structure of the operational status data is shown below.

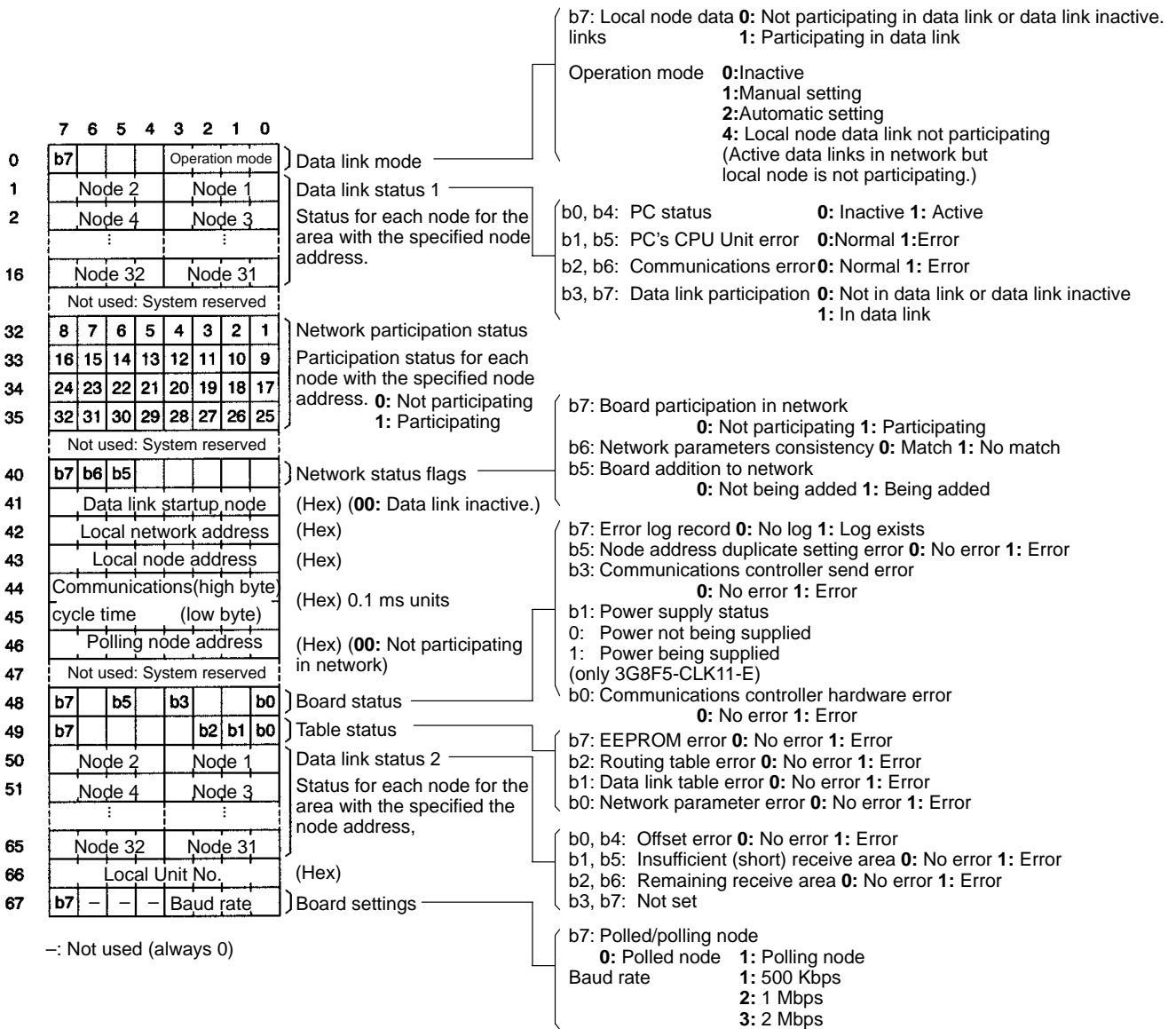

- Note**
1. Before using STATUS READ (05 Hex), be sure to allocate memory to the status area.
  2. Data link status 1 and data link status 2 are valid only when the local node is participating in the data links.
  3. For all Controller Link Support Board nodes, the following status will always exist in data link status 1.  
 PC operation: 1 (active) and PC error: 0 (normal).

**Responses**

The following table shows the possible responses when STATUS READ (05 Hex) is executed.

Response	Meaning
00 Hex	The command was executed normally.
31 Hex	A Support Board error has occurred.
41 Hex	Parameter error.



### 5-3-7 NETWORK ADD/REMOVE — 07 Hex

The NETWORK ADD/REMOVE (07 Hex) driver call is used to add the Support Board to the network or remove it from the network.

#### Call Procedure

AX ← 4403 Hex  
 BX ← File handle (the return value when a file is opened)  
 CX ← 0003 Hex (Total number of bytes in user command packet)  
 DS:DX ← The first address storing the command packet (segment:offset)  
 INT 21 Hex

#### User Command Packet

Offset: Bytes	Content	
+0	04 Hex (function code)	IN
+1	Add/remove command	IN
+2	Response	OUT

#### Parameters

The parameters for NETWORK ADD/REMOVE (07 Hex) are described in the following table.

Parameter	Function
Function code	07 Hex (fixed)
Add/remove command	00 Hex: Add 01 Hex: Remove

#### Description

When NETWORK ADD/REMOVE (07 Hex) is executed, network communications are either started or stopped.

If the Network is left while data links are active, the Controller Link Support Board's data links will stop.

**Note** When the Controller Link Support Board is acting as the polling node and data links are active, wait 3 seconds after leaving the network before adding the Board to the network again.

#### Responses

The following table shows the possible responses when NETWORK ADD/REMOVE (07 Hex) is executed.

Response	Meaning
00 Hex	The command was executed normally.
31 Hex	A Support Board error has occurred.
41 Hex	Parameter error.

### 5-3-8 DATA LINK READ 2 — 20 Hex

The DATA LINK READ 2 (20 Hex) driver call is used to read data from the data link area. DATA LINK READ 2 (20 Hex) can be used only when a data link cache has **not** been set in the Controller Link BIOS option.

#### Call Procedure

AX ← 4403 Hex  
 BX ← File handle (the return value when a file is opened)  
 CX ← 000B Hex (Total number of bytes in user command packet)  
 DS:DX ← The first address storing the command packet (segment:offset)  
 INT 21 Hex

User Command Packet

Offset: Bytes	Content		
+0	20 Hex (function code)		IN
+1	Read start address	(Low)	IN
+2		(High)	IN
+3	Read data storage address Offset	(Low)	IN
+4		(High)	IN
+5	Read data storage address Segment	(Low)	IN
+6		(High)	IN
+7	No. of bytes of data read	(Low)	IN
+8		(High)	IN
+9	Read node address		IN
+A	Response		OUT

Read Data Storage Area

The read data storage area contains all data (No. of bytes of data read) from the read data storage start address.

Offset: Bytes	Content		
+0	Read data	Word data (bits 15 to 8)	OUT
+1		Word data (bits 7 to 0)	OUT
:			:
:			:
+n-2	Read data	Word data (bits 15 to 8)	OUT
+n-1		Word data (bits 7 to 0)	OUT

n: Total No. of bytes read.

Parameters

The parameters for DATA LINK READ 2 (20 Hex) are described in the following table.

Parameter	Function
Function code	20 Hex (fixed)
Read start address	Indicates the offset from the beginning of the data link area for each node. Even numbered bytes 0000 to 07CE Hex (0 to 1998) If odd numbered bytes are specified, a parameter error will occur.
No. of bytes read	Even numbered bytes from 0002 to 07D0 Hex (2 to 2,000.) Maximum No. of send words: 1,000 words, 1 word of data per 2 bytes. If an odd number of bytes is specified, a parameter error will occur.
Read data storage address	Specifies the start address of the "read data storage address" as a segment offset.
Read node address	01 to 20 Hex (1 to 32)

Description

When DATA LINK READ 2 (20 Hex) is executed, the number of bytes of data specified by the No. of bytes read parameter will be read from the data link area beginning at the address specified by the read start address parameter and stored in an internal buffer. If the data links are active, this data will be reflected in the data link areas of other nodes.

When data is read using this driver call, receive data cannot be read again once it has been read until new data has been received (new data is usually received

after one transmission cycle.) If attempts are made to read the same data continuously, an error (no receive data) will result.

In the example below, the m words of the data link area allocated to node 3 are read. There are n words allocated to nodes 1 and 2, so the read start address parameter is set to 2 × n bytes. All m words will be read, so the No. of bytes read parameter is set to 2 × m bytes.

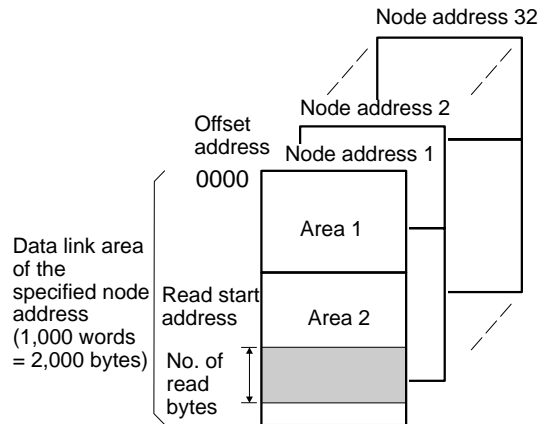

Even-numbered bytes correspond to the leftmost byte of words, and odd-numbered bytes correspond to the rightmost byte of words, as shown below.

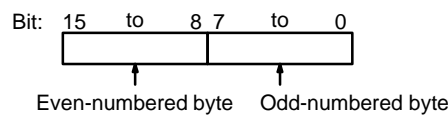

- Note**
1. Before using DATA LINK READ 2 (20 Hex), be sure to allocate enough memory for the read data storage area.
  2. If a data link cache has not been set using the Controller Link BIOS option for in the CONFIG.SYS file, an error will occur (command cannot be executed.)
  3. When DATA LINK READ 2 (20 Hex) is used to read part of the receive data, the remaining unread data cannot be read until new data has been received. Always be sure to read all necessary data at one time.

**Responses**

The following table shows the possible responses when DATA LINK READ 2 (20 Hex) is executed.

Response	Meaning
00 Hex	The command was executed normally.
12 Hex	No receive data
31 Hex	A Support Board error has occurred.
32 Hex	Command cannot be executed.
41 Hex	Parameter error.

**Related Commands**

DATA LINK WRITE 2 (21 Hex)

**5-3-9 DATA LINK WRITE 2 — 21 Hex**

The DATA LINK WRITE 2 (21 Hex) driver call is used to write data to the data link area. DATA LINK WRITE 2 (21 Hex) can be used only when a data link cache has **not** been set using the Controller Link BIOS option.

**Call Procedure**

- AX ← 4403 Hex
- BX ← File handle (the return value when a file is opened)
- CX ← 000B Hex (Total number of bytes in user command packet)
- DS:DX ← The first address storing the command packet (segment:offset)
- INT 21 Hex

**User Command Packet**

Offset: Bytes	Content	
+0	21 Hex (function code)	IN
+1	Write start address (Low)	IN
+2	(High)	IN
+3	Write data storage address Offset (Low)	IN
+4	(High)	IN
+5	Write data storage address Segment (Low)	IN
+6	(High)	IN
+7	No. of bytes of write data (Low)	IN
+8	(High)	IN
+9	Write node address	IN
+A	Response	OUT

**Write Data Storage Area**

The write data storage area contains all data (No. of bytes of write data) from the write data storage address.

Offset: Bytes	Content	
+0	Write data Word data (bits 15 to 8)	OUT
+1	Word data (bits 7 to 0)	OUT
:		:
:		:
+n-2	Word data (bits 15 to 8)	OUT
+n-1	Word data (bits 7 to 0)	OUT

n: Total No. of bytes written.

**Parameters**

The parameters for DATA LINK WRITE 2 (21 Hex) are described in the following table.

Parameter	Function
Function code	21 Hex
Write start address	Indicates the offset from the beginning of the data link area for each node. Even numbered bytes 0000 to 07CE Hex (0 to 1998) If odd numbered bytes are specified, a parameter error will occur.
No. of write bytes	Even numbered bytes from 0002 to 07D0 Hex (2 to 2,000.) Maximum No. of send words: 1,000 words, 1 word of data per 2 bytes.) If an odd number or bytes is specified, a parameter error will occur.
Write data storage address	Specifies the start address of the "write data storage address" using a segment offset.
Write node address	01 to 20 Hex (1 to 32)

**Description**

When DATA LINK WRITE 2 (21 Hex) is executed, the data in the write data storage area will be written to the data link area beginning at the address specified by the write start address parameter. If the data links are active this data will be reflected in the data link areas of other nodes.

In the example below, data from the winkbuf area is written to the m words of the data link area allocated to the Support Board (node 3). There are n words allocated to nodes 1 and 2, so the write start parameter is set to  $2 \times n$  bytes. All m words will be written, so the No. of write bytes parameter is set to  $2 \times m$  bytes.

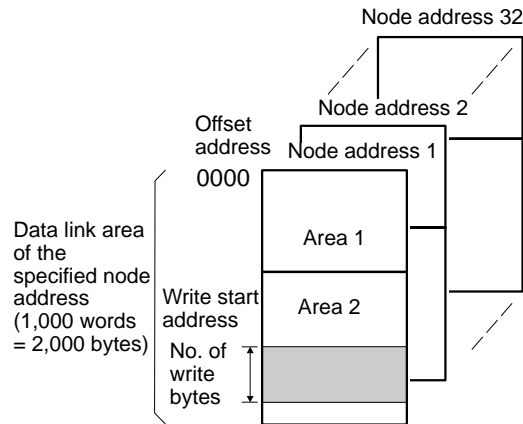

Even-numbered bytes correspond to the leftmost byte of words, and odd-numbered bytes correspond to the rightmost byte of words, as shown below.

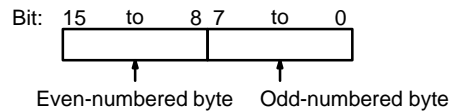

- Note**
1. Data should be written only to the send area of the data link area allocated to the Support Board.
  2. If a data link cache has not been set using the Controller Link BIOS option in the CONFIG.SYS file, an error will occur (command cannot be executed.)
  3. The maximum data link area size per node is 2,000 bytes (1,000 words.) Do not exceed this limit when writing data.

**Responses**

The following table shows the possible responses when DATA LINK WRITE 2 (21 Hex) is executed.

Response	Meaning
00 Hex	The command was executed normally.
31 Hex	A Support Board error has occurred.
32 Hex	Command cannot be executed.
41 Hex	Parameter error.

**Related Commands**

DATA LINK READ 2 (20 Hex)

# SECTION 6

## Data Links

This section describes how to use data links in a Controller Link Network.

- 6-1 What Are Data Links? .....
- 6-1-1 Data Link Specifications .....
- 6-1-2 Differences Between Manual and Automatic Setting .....
- 6-2 Setting Data Links .....
- 6-2-1 Selecting Manual or Automatic Setting .....
- 6-2-2 Manual Setting .....
- 6-2-3 Manual Setting Examples .....
- 6-2-4 Automatic Setting: “Select All” .....
- 6-2-5 Automatic Setting Example .....
- 6-3 Starting and Stopping Data Links .....
- 6-3-1 Using a Programming Device or a Ladder Program .....
- 6-3-2 Using the Controller Link Support Software .....
- 6-3-3 Using FINS Commands .....
- 6-4 Checking Data Link Status .....
- 6-4-1 LED Indicators .....
- 6-4-2 Data Link Status Area .....
- 6-4-3 Checking by Manipulating Bit/Word Status .....

## 6-1 What Are Data Links?

Data links automatically exchange data in the preset areas between nodes (PCs and/or computers) on one network. Data links can be freely created for C200HX/HG/HE PCs, CV-series PCs, CS1-series PCs, and IBM PC/AT or compatible computers.

Two data link areas, area 1 and area 2, can be set for each node. Data links can be set in either of the following ways.

- Data link areas can be manually set by inputting data link tables through Controller Link Support Software. Data link tables are created to define the data links. These tables enable free allocation of data link areas.
- Data links can be set automatically from a Programming Device. With automatically set data links, all link areas are the same size.

Both automatic setting and manual setting cannot be used together in the same network. The following rules apply to these two methods of setting data links.

- Data links are enabled concurrently for area 1 and area 2.
- Separate settings (first link words and send area size) are made in area 1 and area 2. The sequences of send and receive words are the same in area 1 and area 2.
- Not all nodes must participate in the data links.

### Manually Setting Data Links

Example 1: The order of send and receive nodes is free.

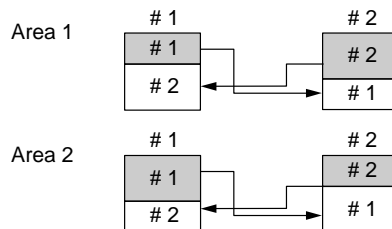

Example 2: Some nodes can send data without receiving data.

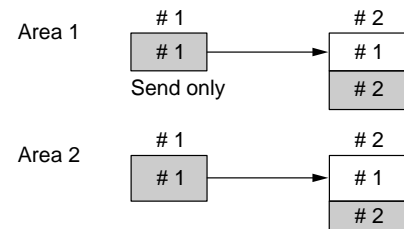

Example 3: Some nodes can receive data without sending data.

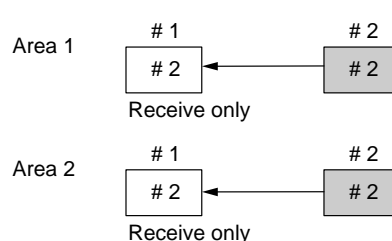

Example 4: A node can receive only a specified number of words from the beginning of an area.

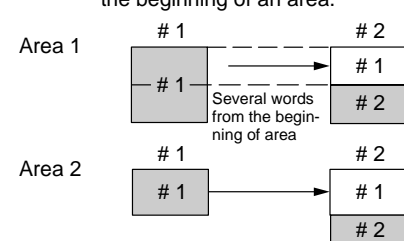

Manually set data links are used to create flexible data links that meet the needs of the individual system.

- Data links are set in the Controller Link Unit or Board of each node using the Controller Link Support Software or CX-Programmer.
- At PCs, area 1 and area 2 can be selected from memory areas, including the DM Area and EM Area.
- A send area and its size can be allocated freely for each node.
- The sequence of receive nodes can be changed.
- Nodes can be set that only send or only receive data.
- Only part of send data can be received and an offset can be used to specify the beginning of the desired part.

**Manual Setting Options**

The following options can be set when manually setting data links.

**Offsets**

Data of only the specified number of words can be received starting from the specified word position. The starting word is set as an offset from the beginning of the send data. The following is an example.

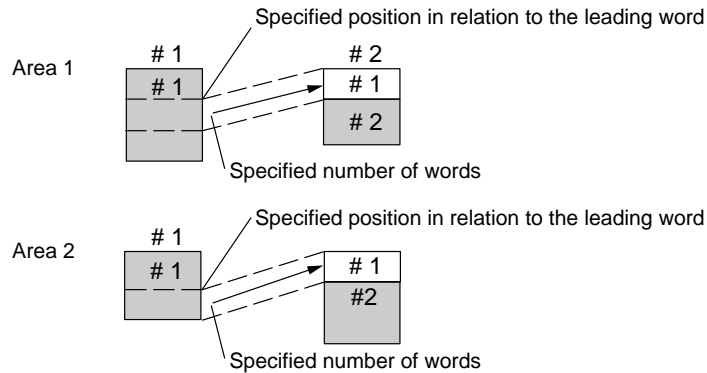

**Easy Setting: “Set All”**

The send data areas of all nodes can be set to the same size (same as for automatic setting described next).

**Note** Easy Setting appears as “Set All” on the Controller Link Support Board screen.

**Automatically Setting Data Links**

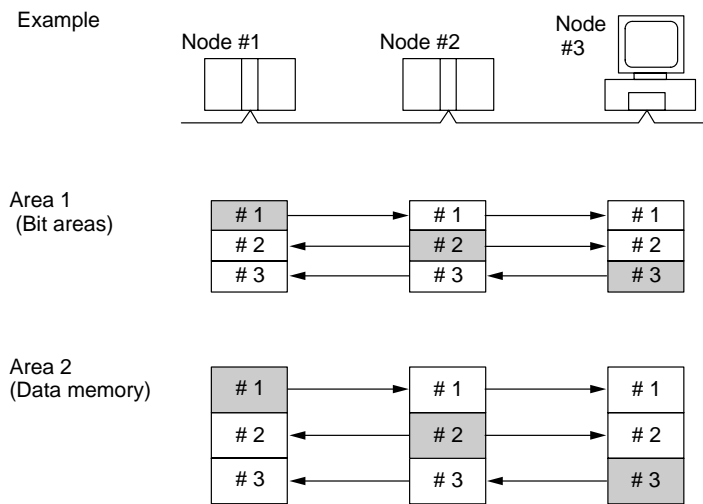

Automatic setting can be used to create simple data links.

- Using a Programming Device (such as a Programming Console), set the automatic data link mode in the DM parameter area of the startup node.
- Area 1 can be selected from bit areas (i.e., IR, CIO, and LR areas) and area 2 can be selected from Data Memory.
- A computer cannot be used as the startup node if data links are being automatically set. When automatically setting data links, computers can only participate in the data links.
- The maximum number of send/receive words is 8,000 when data links are automatically set, even for computers. This is because computers rely on the Controller Link Unit settings in the startup node.
- In areas 1 and 2 send areas for each node are of the same size.
- Send nodes are in the same ascending order as node numbers.
- It is not possible to receive only a part of send data.



- All nodes can be specified to either participate or not participate in the data link.
- The data link areas are exactly the same and common to all nodes participating in the data links.

**Note** The Controller Link Support Software contains a function called “Easy Setting” that can be used within the manual data link mode to register the same data links as automatic setting. This Easy Setting can be used first, and then the send size of each node and other settings can be changed as required.

### Using Offsets

For automatically set data links, all of the send words transmitted by a node are received by other nodes with no change in size. For manually set data links, the size of a receive area can be restricted by specifying a number of words from the beginning word of the words sent by another node.

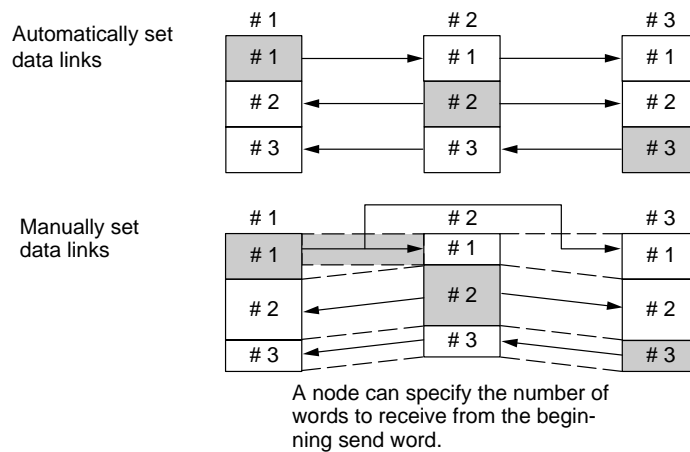

However, the above system does not guarantee that only the desired words will be received and there is a good chance that unnecessary data will also be received.

Offsetting enables specification of a more specific range of receive data by indicating both the number of words and the starting word position from the beginning of the area. The offset refers to the starting word position counted from the beginning of the area.

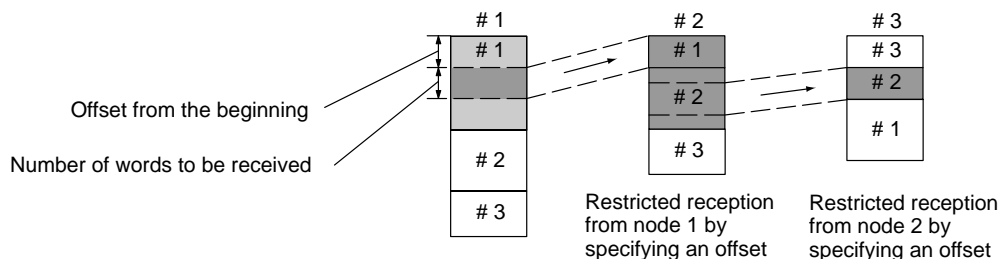

**Application Example of Using Offsets**

In the following example, the send data from node 1 is split into three parts and each part is received by a different node, i.e., each of the other nodes receives only part of the send data from node 1. This enables effective use of data link memory areas without wasting space. In this way, a type of message service (i.e., specific data to a specific node) can be achieved through data links.

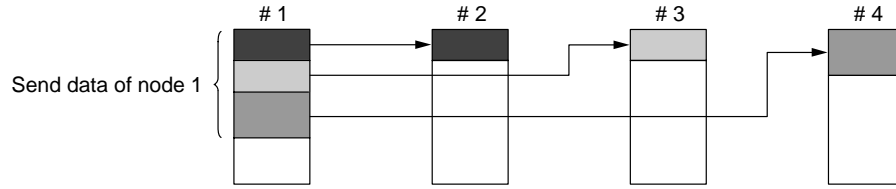

**6-1-1 Data Link Specifications**

Item	Description	
No. of data link nodes	32 max., 2 min.	
Number of data link words	Number of send/receive words per node (total of area 1 and area 2) : CS1: Up to 12,000 C200HX/HG/HE, CV: Up to 8,000 IBM or compatible: Manual setting: Up to 32,000 Automatic setting: Up to 8,000 Number of send words per node (total of area 1 and area 2): Up to 1,000	
Allocation of data link areas	Manual setting	Area 1, 2: Bit area (IR, CIO, and LR Areas) Data Memory (DM and EM Areas) However, area 1 and area 2 cannot be set in the same memory area.
	Automatic setting	Area 1: IR, CIO, or LR Area Area 2: Data Memory (DM and EM Areas)

### 6-1-2 Differences Between Manual and Automatic Setting

Item	Manual setting	Automatic setting
Determination of nodes participating in a data link	Determined by setting data link tables.	Determined by the data link parameters set in the data link startup node (the node used to start the data links).
Data link settings	Set in data link tables that are set in the nodes to participate in data links.	Determined by the data link parameters set in the data link startup node (the node used to start the data links).
Data link areas 1 and 2	In each node, area 1 and area 2 are selected from bit areas (IR, CIO, and LR Areas) and Data Memory (DM and EM Areas). However, areas 1 and 2 cannot be set in the same memory area.	Area 1 is selected from bit areas (IR, CIO, and LR Areas) and area 2 is selected from Data Memory (DM and EM Areas).
Refresh starting word	Can be set freely in each node. (See note a))	Can be set freely. (See note a))
Data link status area	Selected from bit areas (IR, CIO, and LR Areas) and Data Memory (DM and EM Areas) in each node.	Selected from bit areas (IR or CIO Areas).
Refresh sequence	Can be set in each node freely.	Node addresses are in ascending order.
Data reception	It is possible to set in each node whether the entire data or a part of the data sent from another node is received. It is also possible to not receive the data sent from a specific node. (See note b))	The entire data sent from each node that is participating in the data link is received.
Data transmission	The send sizes can be set freely in each node. It is also possible for certain node not to send data. (See note b))	In area 1 and area 2, data send sizes are the same in each node.

- Note** a) The following are true for computer nodes (i.e., computers with a Controller Link Support Board mounted).
- The data link starting position is fixed.
  - Because areas such as bit areas and DM are not available, areas must be made available on the computer for linking.
  - Automatically set data links cannot be started from the Controller Link Support Board.
  - The Controller Link Support Board can participate in automatically set data links.
- b) If data links are manually set, send/receive area can be selected in each node, allowing send/receive groups to be created within the network in area 1 and area 2, as shown below.

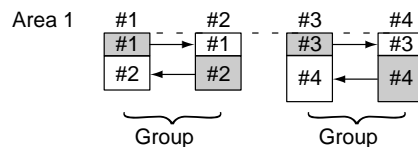

## 6-2 Setting Data Links

### 6-2-1 Selecting Manual or Automatic Setting

Specify either the manual or automatic data link mode in the following DM parameter area of the PC's CPU Unit of the startup node, using a PC Programming Device.

- Note** 1. The data link mode can only be specified in the Controller Link Unit. Refer to the *Controller Link Units Operation Manual (W309)* for more details.

2. When the Controller Link Support Board has been set as the startup node, data links must be manually set.
3. A data link mode can be set in a data link startup node only. The data link mode setting is determined by the data link mode of the startup node even if the data link mode settings of the nodes participating in the data links are different from the settings in the startup node.
4. In manual setting, a data link table must be set in the data link startup node and in automatic setting, automatic data link setting parameters must be set in the data link startup node. Data links will not be started unless the settings are correct.

### 6-2-2 Manual Setting

Transfer the data link tables that were created on the Controller Link Support Software to the Controller Link Unit and the Controller Link Support Board at all node participating in the data links.

#### Transferring from a Programming Device

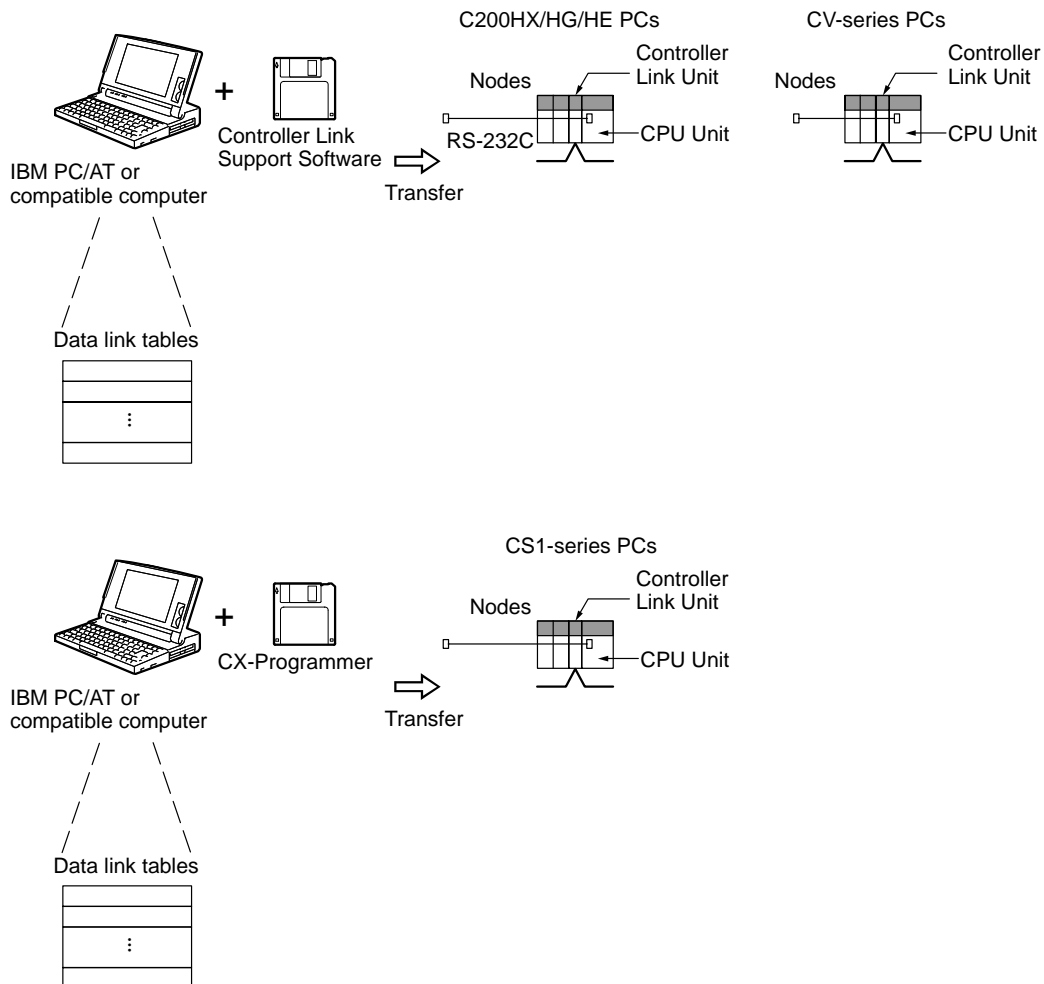

**Note** 1. It is not possible to connect to a CS1-series PC's serial port. Use the CX-Programmer. It is possible to set a CS1-series Controller Link Unit through the network from a computer running the Controller Link Support Software when that computer is connected to a C200HX/HG/HE or CV-series PC. Refer to the *Controller Link Support Software Operation Manual (W308)* for details.

2. When transferring the data link tables to a Controller Link Unit for a CV-series PC, set the System Protect Keyswitch on the CPU Unit to "NORMAL." Otherwise, data link tables cannot be written normally.
3. The Controller Link Support Software can be integrated into the SYSMAC Support Software. Refer to the *Controller Link Support Software Operation Manual (W308)* for details.

### Transferring from a Computer Node

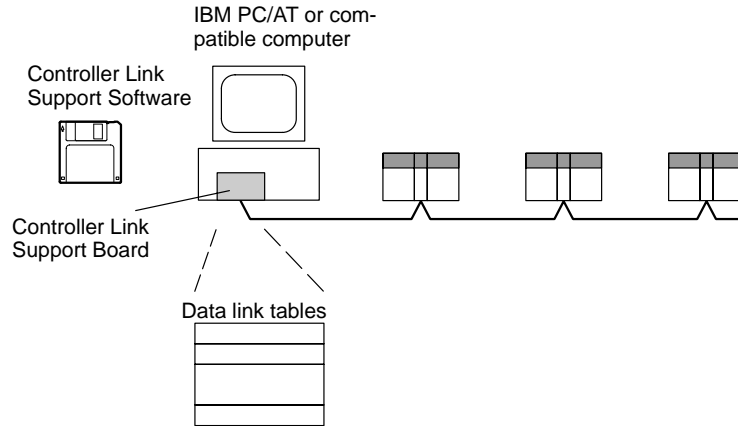

**Note** To create data link tables for nodes in the network using the Controller Link Support Software, the network must have been constructed correctly. Set routing tables at each node as required. When using manually set data links, be sure to delete data link tables for all nodes not participating in data link. See *1-4 Applications Precautions* for details.

### Data Link Table Specifications for Controller Link Support Boards

Setting item		Setting range
PC model		Set as CLK Board.
Nodes		1 to 32 Set the addresses of the refresh nodes. When a data link cache area is set using the BIOS option, the data links will be refreshed in the same order.
First data link status word		The first data link status word is fixed; the setting cannot be changed. Set to -.
Area 1	Data link start word	CIO 0 to 2555, LR 0 to 199, DM 00000 to 24575, EM 0 to 32765 (Banks 0 to 7) The Controller Link Support Board uses both area 1 and area 2, but the address set for the first link word is not used. The areas, however, must be set and the same area cannot be set for both area 1 and area 2. Set different areas.
	Number of words	Remote nodes: 0 to the number of source words Set the number of words to be received. Local node: 0 to 1,000 Set the number of words to be transmitted. The total number of words in area 1 and area 2 in each node must not exceed 1,000. The numbers of words in both area 1 and area 2 in each node must not be set to 0.
	Offset	Remote nodes: 0 to one less than number of source words Set the offset for the data to be received. Local node: Cannot be set. This setting is not required if an offset is not used.

Setting item		Setting range
Area 2	Data link start word	CIO 0 to 2,555, LR 0 to 199, Dm d to 24,575, EM 0 to 32,765 (Banks 0 to 7) The Controller Link Support Board uses both area 1 and area 2, but the address set for the first link word is not used. The areas, however, must be set and the same area cannot be set for both area 1 and area 2. Set different areas.
	Number of words	Remote nodes: 0 to the number of source words Set the number of words to be received.  Local node: 0 to 1,000 Set the number of words to be transmitted.  The total number of words in area 1 and area 2 in each node must not exceed 1,000. The numbers of words in both area 1 and area 2 in each node must not be set to 0.
	Offset	Remote nodes: 0 to one less than number of source words Set the offset for the data to be received.  Local node: Cannot be set.  This setting is not required if an offset is not used.

- Note**
- The maximum number of words for area 1 and area 2 combined must be no more than 32,000.
  - The Controller Link Support Board uses both area 1 and area 2, but the addresses set for the data link start words are not used. The areas, however, must be set and the same area cannot be set for both area 1 and area 2.

**Example:**

Area 1: CIO 00000  
Area 2: DM 00000

- Be sure to delete data link tables for all nodes not participating in the data links.

### 6-2-3 Manual Setting Examples

This section shows examples of manually creating data link tables on the Controller Link Support Software. Sample files containing the data link tables are provided on the installation disk.

Refer to the *Controller Link Support Software Operation Manual (W308)* for actual operating procedures.

**SAMPLE1.CLK: Same Allocation to All Nodes**

Data Link Area Structure

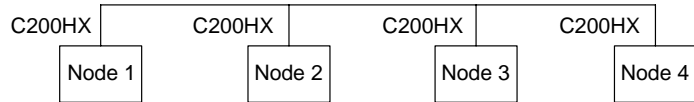

Data Link Areas

Area 1

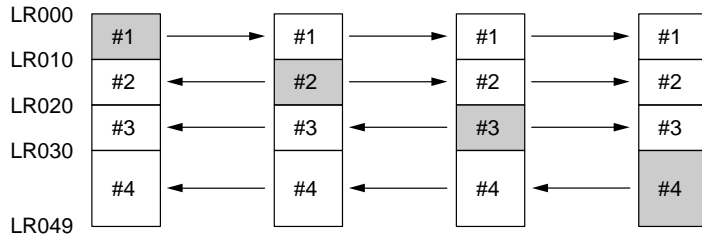

Area 2

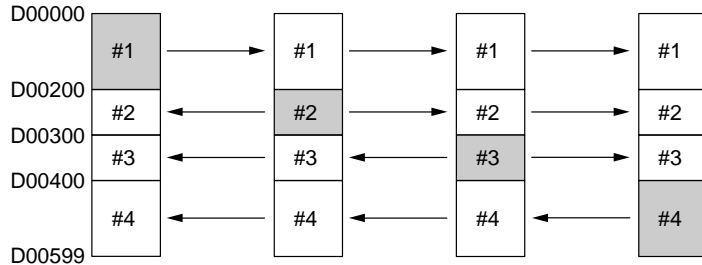

Device Information Settings

Device Info set DataLink table

Node	Model name	Node	Model name
01	C200HX	17	
02	C200HX	18	
03	C200HX	19	
04	C200HX	20	
05		21	
06		22	

Data Link Tables

Node(01) Pctype(C200HX) Num of Nd ( 4) Edit DataLink table Status Word( )

Node	<Area1> Link Id	Link Start Word(100000) Num Id	Source Id	<Area2> Link Id	Link Start Word(D00000) Num Id	Source Id
01	L00000	10	Send Area	D00000	200	Send Area
02	L00010	10	L00010	D00200	100	D00200
03	L00020	10	L00020	D00300	100	D00300
04	L00030	20	L00030	D00400	200	D00400

Set exactly the same table for nodes 2, 3, and 4. To do this, the copy function can be used to copy the data link table for node 1 to nodes 2, 3, and 4.

Checking the Data Link Tables

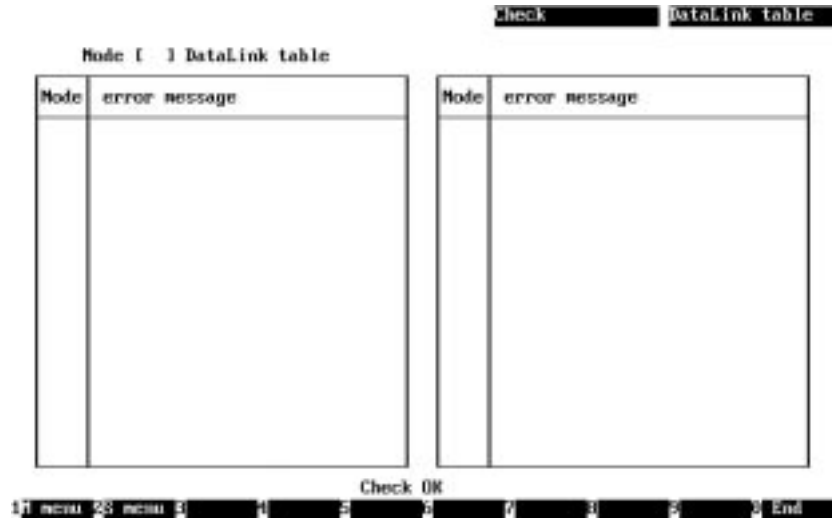

Transferring the Data Link Tables

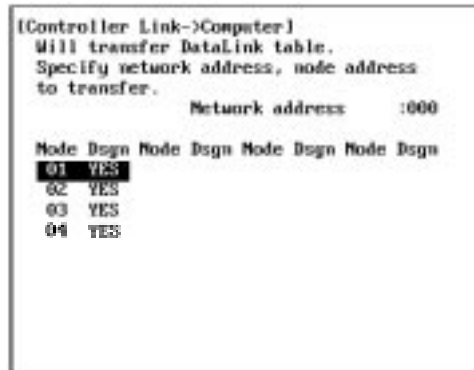

Saving the Data Link Tables





**SAMPLE2.CLK: Different Allocations to Each Node**

Data links can be created so that one node does not receive from all other nodes or so that some nodes do not send or receive any data at all. In the following example, node 2 does not receive data from node 3 and node 3 does not receive data from node 1. Node 4 does not send any add; it only receives data from other nodes.

**Data Link Area Structure**

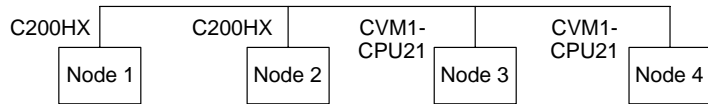

**Data Link Areas**

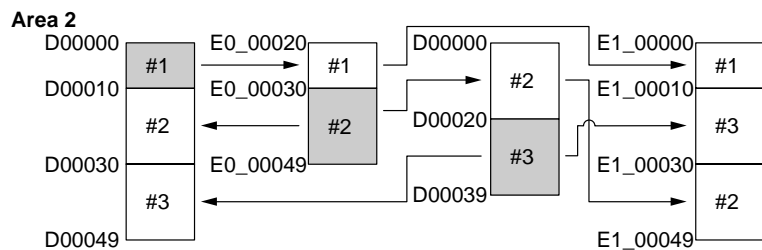
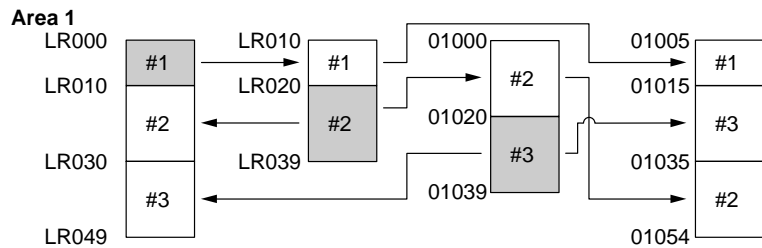

Only nodes in which a data link table has been created can participate in the data links.

In the data link table, the node sequence can be changed freely; however, the data link areas must be created consecutively.

**Device Information Setting**

Device Info set    DataLink table

Node	Node1 name	Node	Node1 name
01	C200HX	17	
02	C200HX	18	
03	CVM1-CPU21	19	
04	CVM1-CPU21	20	
05		21	
06		22	

Data Link Tables

Node(01) PType(C200HX ) Num of Nd ( 3)		Edit		DataLink table		
		Status Word(-----)				
Node	<Area1> Link Wd	Link Start Num Wd	Word(L00000) 1 Source Wd	<Area2> Link Wd	Link Start Num Wd	Word(D00000) 1 Source Wd
01	L00000	10	Send Area	D00000	10	Send Area
02	L00010	20	L00020	D00010	20	E0_00030
03	L00030	20	01020	D00030	20	D00020

Node(02) PType(C200HX ) Num of Nd ( 2)		Edit		DataLink table		
		Status Word(-----)				
Node	<Area1> Link Wd	Link Start Num Wd	Word(L00010) 1 Source Wd	<Area2> Link Wd	Link Start Num Wd	Word(E0_00020) 1 Source Wd
01	L00010	10	L00000	E0_00020	10	D00000
02	L00020	20	Send Area	E0_00030	20	Send Area

Node(03) PType(CVM1-CPU21) Num of Nd ( 2)		Edit		DataLink table		
		Status Word(-----)				
Node	<Area1> Link Wd	Link Start Num Wd	Word(01000) 1 Source Wd	<Area2> Link Wd	Link Start Num Wd	Word(D00000) 1 Source Wd
02	01000	20	L00020	D00000	20	E0_00030
03	01020	20	Send Area	D00020	20	Send Area

Node(04) PType(CVM1-CPU21) Num of Nd ( 3)		Edit		DataLink table		
		Status Word(-----)				
Node	<Area1> Link Wd	Link Start Num Wd	Word(01005) 1 Source Wd	<Area2> Link Wd	Link Start Num Wd	Word(E1_00000) 1 Source Wd
01	01005	10	L00000	E1_00000	10	D00000
03	01015	20	01020	E1_00010	20	D00020
02	01035	20	L00020	E1_00030	20	E0_00030

**SAMPLE3.CLK: Creating Data Link Groups within a Network**

A data links consisting of multiple groups within a single network can be created by setting data link tables. Send and receive areas are created for only the nodes in each group, as shown below.

Data Link Area Structure

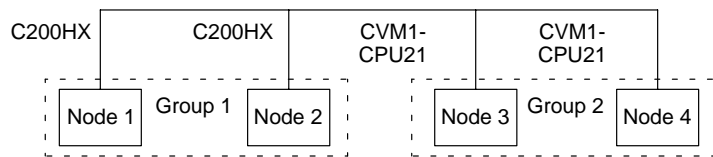

Data Link Areas

Area 1

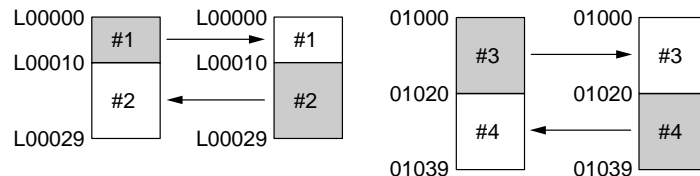

Area 2

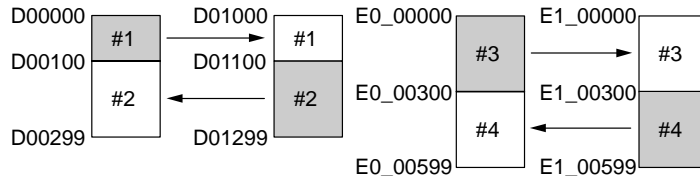

Device Information Setting

Device Info set DataLink table

Node	Model name	Node	Model name
01	C200HX	17	
02	C200HX	18	
03	CUM1-CPU21	19	
04	CUM1-CPU21	20	
05		21	
06		22	

Data Link Tables

Edit DataLink table

Node(01) Pctype(C200HX ) Num of Nd ( 2) Status Word(-----)

Node	<Area1> Link Wd	Link Start Word	Num Wd	Source Wd	<Area2> Link Wd	Link Start Word	Num Wd	Source Wd
01	L00000	10	Send Area		D00000	100	Send Area	
02	L00010	20	L00010		D00100	200	D01100	

Edit DataLink table

Node(02) Pctype(C200HX ) Num of Nd ( 2) Status Word(-----)

Node	<Area1> Link Wd	Link Start Word	Num Wd	Source Wd	<Area2> Link Wd	Link Start Word	Num Wd	Source Wd
01	L00000	10	L00000		D01000	100	D00000	
02	L00010	20	Send Area		D01100	200	Send Area	

Edit DataLink table

Node(03) Pctype(CUM1-CPU21) Num of Nd ( 2) Status Word(-----)

Node	<Area1> Link Wd	Link Start Word	Num Wd	Source Wd	<Area2> Link Wd	Link Start Word	Num Wd	Source Wd
03	01000	20	Send Area		E0_00000	300	Send Area	
04	01020	20	01020		E0_00300	300	E1_00300	

Edit DataLink table

Node(04) Pctype(CUM1-CPU21) Num of Nd ( 2) Status Word(-----)

Node	<Area1> Link Wd	Link Start Word	Num Wd	Source Wd	<Area2> Link Wd	Link Start Word	Num Wd	Source Wd
03	01000	20	01000		E1_00000	300	E0_00000	
04	01020	20	Send Area		E1_00300	300	Send Area	

**SAMPLE4.CLK: Receiving Only Part of Send Data and Offsets**

**Note** Only area 2 is used in this example.

**Data Link Area Structure**

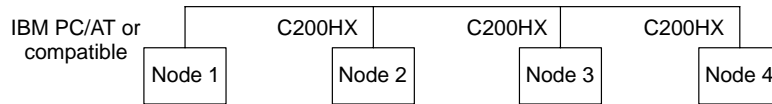

**Data Link Areas (With Data Link Cache)**

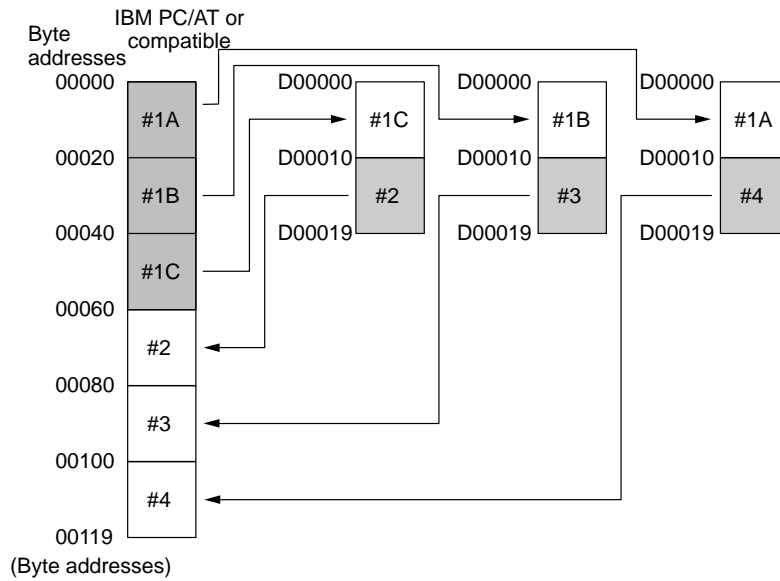

**Data Link Areas (Without Data Link Cache)**

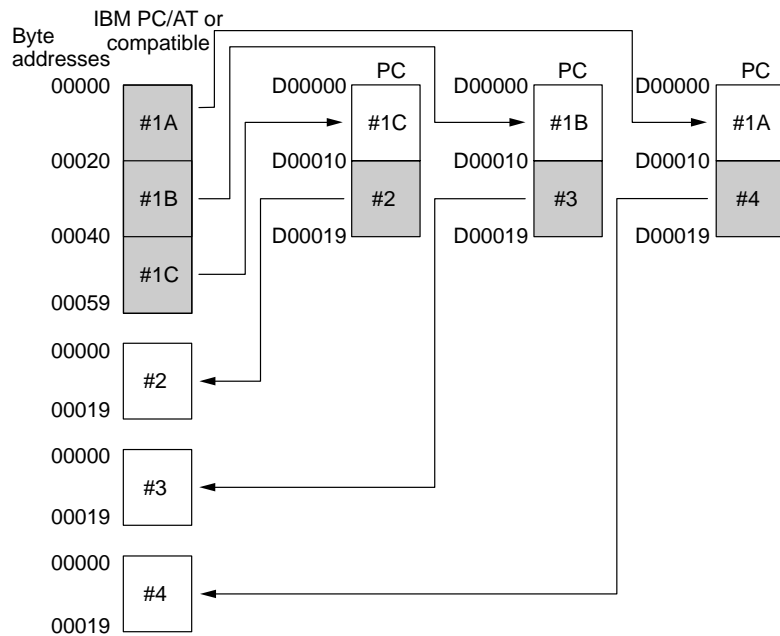

Device Information Setting

Device Info set DataLink table

Node	Model name	Node	Model name
01	CLK Board	17	
02	C200HX	18	
03	C200HX	19	
04	C200HX	20	
05		21	
06		22	

Data Link Tables

Node[01] Pctype[CLK Board ] Num of Nd [ 4] Edit DataLink table  
Status Word[-----]

Node	<Area1> Link Wd	Link Start Word[00000] 1 Num Wd Source Wd	<Area2> Link Wd	Link Start Word[D00000] 1 Num Wd Source Wd
01	00000	0 Send Area	D00000	30 Send Area
02	00000	0 00000	D00030	10 D00010
03	00000	0 00000	D00040	10 D00010
04	00000	0 00000	D00050	10 D00010

Node[02] Pctype[C200HX ] Num of Nd [ 2] Edit DataLink table  
Status Word[-----]

Node	<Area1> Link Wd	Link Start Word[00000] 1 Num Wd Source Wd Offset	<Area2> Link Wd	Link Start Word[D00000] 1 Num Wd Source Wd Offset
01	00000	0 00000 0	D00000	10 D00020 20
02	00000	0 Send Area ---	D00010	10 Send Area ---

Node[03] Pctype[C200HX ] Num of Nd [ 2] Edit DataLink table  
Status Word[-----]

Node	<Area1> Link Wd	Link Start Word[00000] 1 Num Wd Source Wd Offset	<Area2> Link Wd	Link Start Word[D00000] 1 Num Wd Source Wd Offset
01	00000	0 00000 0	D00000	10 D00010 10
03	00000	0 Send Area ---	D00010	10 Send Area ---

Node[04] Pctype[C200HX ] Num of Nd [ 2] Edit DataLink table  
Status Word[-----]

Node	<Area1> Link Wd	Link Start Word[00000] 1 Num Wd Source Wd	<Area2> Link Wd	Link Start Word[D00000] 1 Num Wd Source Wd
01	00000	0 00000	D00000	10 D00000
04	00000	0 Send Area	D00010	10 Send Area

6-2-4 Automatic Setting: "Select All"

Data links can be automatically created by setting values in the DM parameter area of the PC's CPU Unit of the startup node. The settings are made using a Programming Console "or the SYSMAC Support Software.

The startup node is the node from which the data links are activated. When automatically setting data links, data link operation is based on the values set in the startup node.

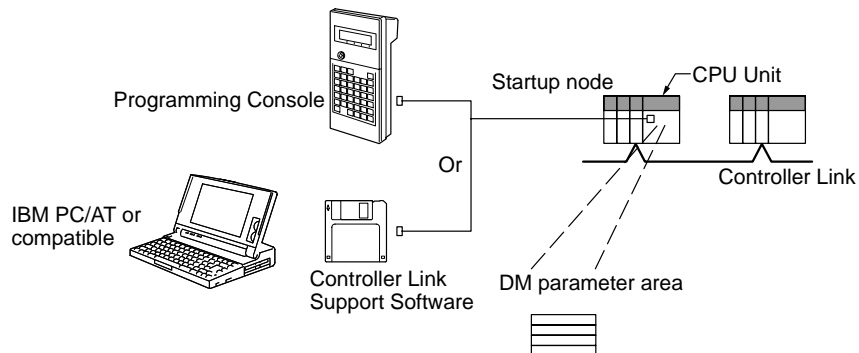

- Note**
1. Parameters for automatically setting data links can only be set in PCs. Refer to the *Controller Link Units Operation Manual (W309)* for details.
  2. An IBM PC/AT or compatible computer (Controller Link Support Board) cannot be the startup node for an automatically setting data links.
  3. An IBM PC/AT or compatible computer can participate in automatically set data links. Data link tables are not required in the computer (the data link tables in the startup node will be used).

### 6-2-5 Automatic Setting Example

This section shows an example of DM parameter area settings and the data link areas that are created as a result.

#### DM Parameter Area Settings

Set the parameters in the startup node as follows:

N	0 0 1 0	← Data link mode: Automatic
N+1	0 0 0 0	← Area 1 data link start word: LR 00
N+2	8 6 0 0	
N+3	0 0 1 0	← Number of words: 10
N+4	1 0 0 0	← Area 2 data link start word: DM 1000
N+5	8 2 0 0	
N+6	0 2 0 0	← Number of words: 200
N+7	0 3 1 0	← First data link status word: IR 310
N+8	0 0 0 7	← Participating nodes: #1, #2, and #3
N+9	0 0 0 0	

#### Data Link Areas Created

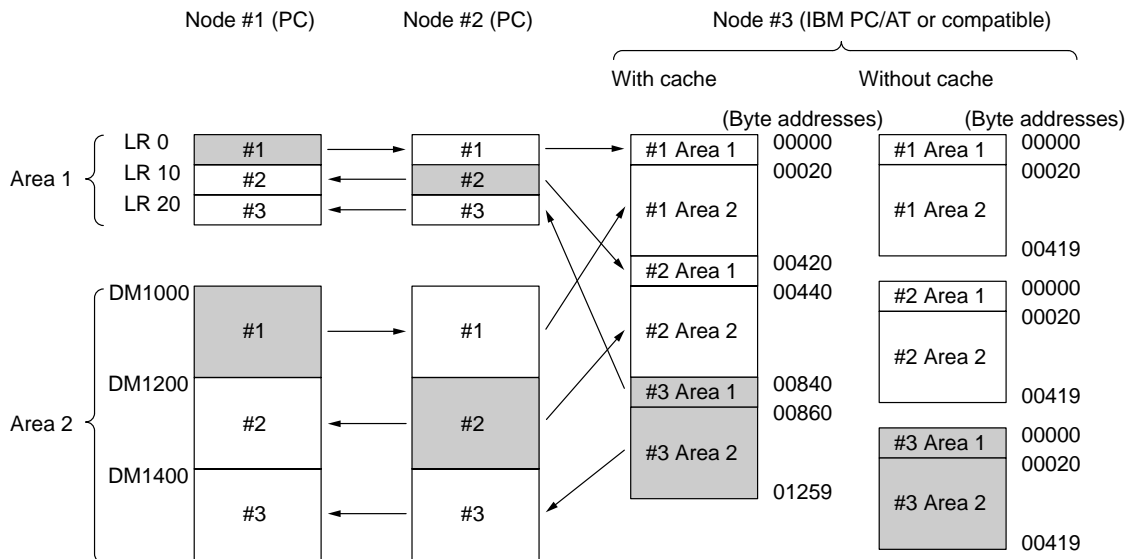

## 6-3 Starting and Stopping Data Links

Data link must be started after data link areas have been created. Use any of the methods described below for the startup node to start and stop data links. These methods are the same for both manually and automatically set data links.

- Note** The data link mode (manual setting or automatic setting) and data link method are determined according to the data link setting in the startup node. In the startup node, set a data link table in the case of manual setting and data link automatic setting parameters in the case of automatic setting. If the settings are incorrect, the data link will not start.

**Caution** Check the following items before starting data links. If incorrect data link tables or parameters are set, injury may result due to unexpected operation of the system. Even if the correct data link tables and parameters have been set, do not start or stop data links before verifying that there will be no adverse influence on the system.

• **Manually Set Data Links**

Check the data link tables in each node participating in the data link to see that they are correct.  
Be sure that data link tables are deleted from nodes that are not participating in the data links.

• **Automatically Set Data Links**

Be sure that the correct DM parameters have been set in the data link startup node.

### 6-3-1 Using a Programming Device or a Ladder Program

Set the software switches (AR or DM Start Bit) in the PC to ON using a Programming Device or from the ladder-diagram program.

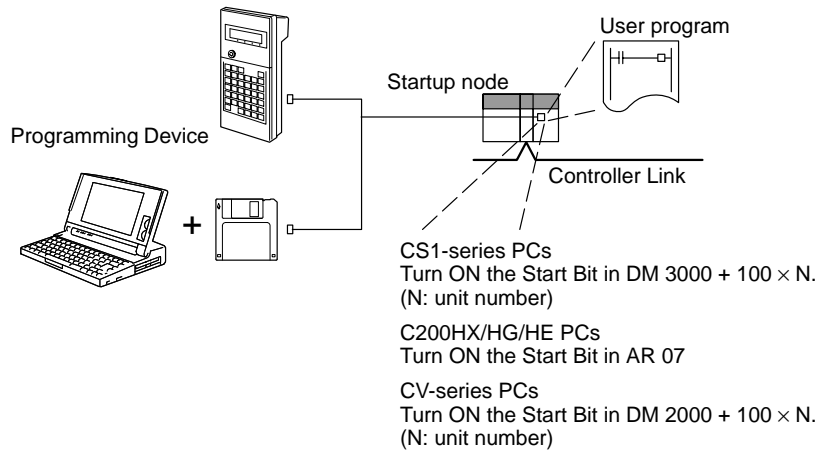

The data links will start when the Start Bit changes from OFF to ON or is already ON when power is turned ON. The data links will stop when the Start Bit changes from ON to OFF.

- Note**
1. Refer to the *Controller Link Units Operation Manual (W309)* for details on starting and stopping data links using a Programming Device or ladder program.
  2. The data in the AR and DM Areas is retained when power is turned off. Therefore, by setting in the AR and DM Areas can be made in advance to start data links as soon as power is turned on. It is recommended to set the Start Bit to ON in multiple nodes that are participating in the data link so that the data links will start even if the startup node is down. The same data link settings must be set in these nodes for automatically set data links.

#### CS1-series Startup Node

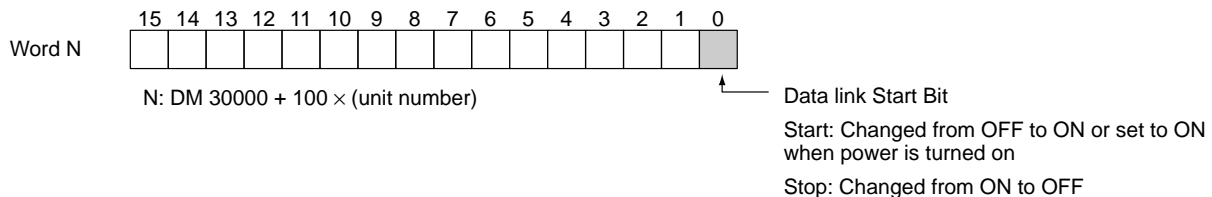

**C200HX/HG/HE Startup Node**

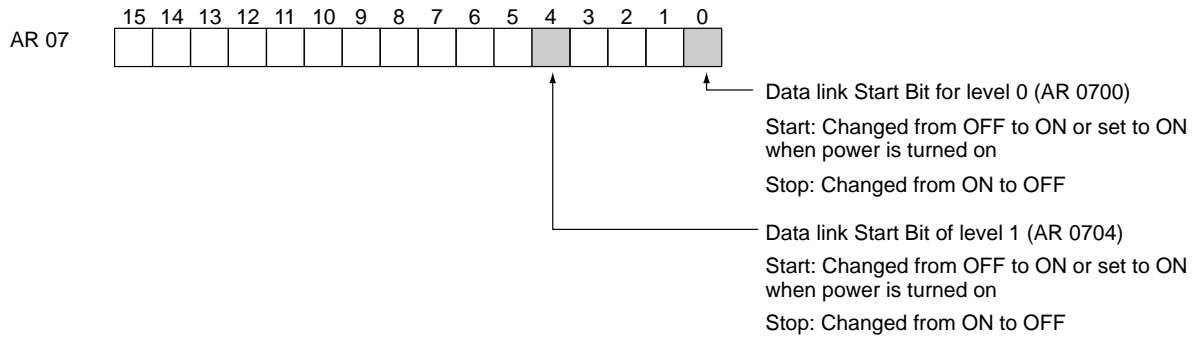

**CV-series Startup Node**

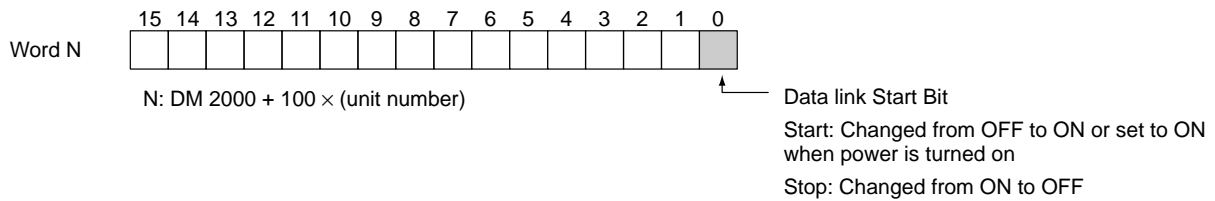

**6-3-2 Using the Controller Link Support Software**

Data links can be started or stopped using from the command on the Data Link Menu of the Controller Link Support Software. The node for which starting and stopping is being specified must participate in the data links.

**Using a Programming Device Connected to PC Node**

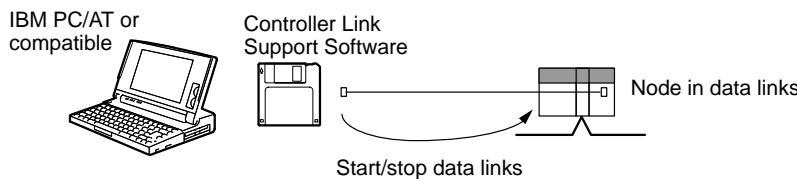

**Using a Computer Node**

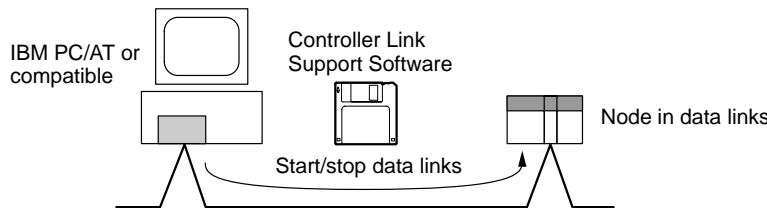

Data links can be started or stopped from the Controller Link Support Board on the local node.

**6-3-3 Using FINS Commands**

Data links can be started and stopped by sending the DATA LINK START and DATA LINK STOP FINS commands from a node on the Controller Link to a node that is in the data links.

**Issuing the FINS Command from a Computer Node**

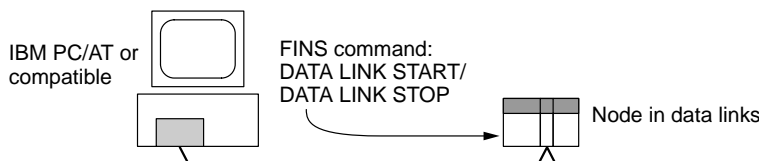



Issuing the FINS Command from CV-series and CS1-series PCs

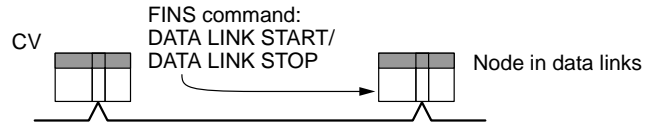

## 6-4 Checking Data Link Status

There are two methods for checking the status of active data links:

- Check the LED indicators on the front of the Units.
- Check the data link status area.

### 6-4-1 LED Indicators

Check the LNK indicator on the front of the Board.

Wired Board



Optical Board

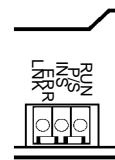

Make sure that the LNK indicator is ON at nodes participating in the active data links.

Name	Color	Status	Contents
LNK (data link)	Yellow	ON	Participating data links.
		Flashing	Data link table setting error.
		OFF	Not in data links or data links are inactive.

The LNK indicator will be lit at all node participating in the data links as long as operation is normal. The data link mode (manual/automatic) can be checked using the M/A indicator. The M/A indicator is only available in the Controller Link Unit and cannot be used in the Controller Link Support Board. See *10-1 Troubleshooting Using Indicators* for details.

### 6-4-2 Data Link Status Area

The data link status area can be used to check for errors when data link does not operate normally even though no abnormality has been detected by the computer or the Controller Link Support Board. Data link status can be read using the STATUS READ command.

See *10-2 Status Information and Troubleshooting* for troubleshooting procedures.

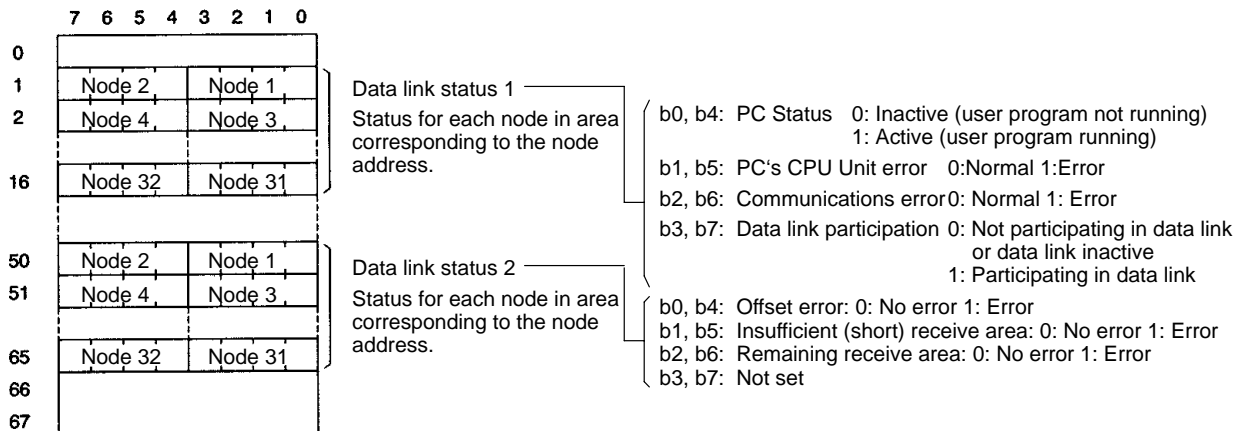

Status	Values	Description
PC status	0: Program execution stopped 1: Program being executed	Indicates if the PC program is being executed or not. Always 1 for Controller Link Support Board nodes.
CPU Unit error	0: No error 1: Error	Indicates if an error has occurred in the PC. Always 0 for Controller Link Support Board nodes.
Communications error	0: Normal 1: Error	Indicates if data link data for node was received normally or not.
Data link participation	0: Not participating in data links or data links inactive 1: Participating in data links	Indicates data link participation status.
Offset error	0: No error 1: Error	“Error” indicates that the offset is larger than the number of send words. The data links will operate and the node will remain participating in the data links. The receive area at nodes with this error will be all zeros.
Receive area remaining	0: No receive area remaining 1: Receive area remaining	A receive area is “remaining” if the number of words in the receive area is larger than the number of send words. Data will be received normally and all words in the receive area beyond those containing the send words will have indeterminate status.
Insufficient (short) receive area	0: Receive area not short 1: Receive area short	A receive area is “short” if the number of send words is larger than the number of words in the receive area. Data will be received normally, but all words that will not fit in the receive area will be discarded.

- The following shows an example of a remaining receive area.

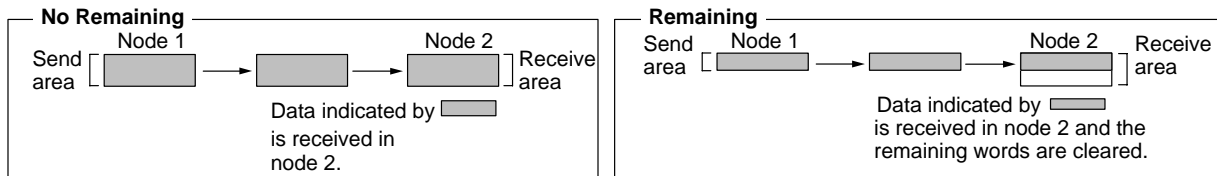

- The following shows an example of an insufficient receive area.

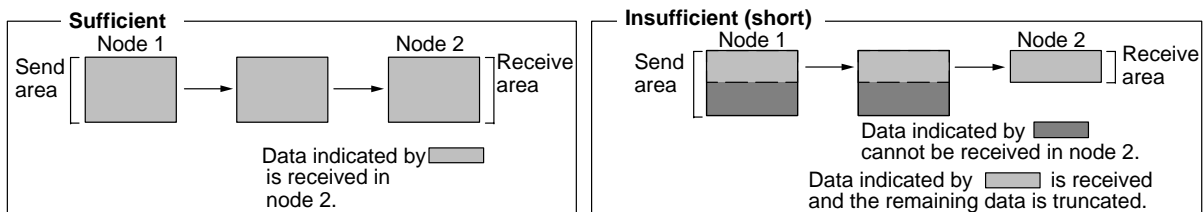

- Note**
1. A communications error will occur in a node that is not participating in the network.
  2. When a communications error occurs or a node is separated from the network, previous status will be retained for other node status.
  3. A node which is participating in the network but is not participating in the data links will show the PC operating status and PC error.
  4. On the Controller Link Support Board, a node participating in the network but not in the data links will show the PC operating status, PC errors, communications errors, and data link participation for all nodes.
  5. When there is not enough receive data to filling a receive area (“area remaining”) at a computer node, the status of the rest of the receive area will be indeterminate.

### 6-4-3 Checking by Manipulating Bit/Word Status

Although the data link function itself may be operating correctly, the data link areas may have been input incorrectly.

After you have confirmed that the data link function is operating normally, check to see whether or not the data link is operating as intended, i.e., check to see if the desired bits/words data is being transferred to the intended words at other nodes.

Change the contents of a bit or word in a data link send area using a Programming Device or the user program and check whether the change is reflected in data link areas of other nodes as intended.

The contents of the data link areas set on the local node for the Controller Link Support Board can be read and written using the data link monitor function on the Controller Link Support Software. For details refer to the *Controller Link Support Software Operation Manual (W308)*.

# SECTION 7

## Message Service

This section explains how to use the message service provided by a Controller Link Support Board.

7-1	Introduction .....
7-1-1	Message Service Specifications .....
7-1-2	Functions and Library Calls .....
7-1-3	Using the Message Service .....
7-1-4	Message Service Processing .....
7-1-5	FINS Commands for the Support Board .....
7-2	FINS Command/Response Format .....
7-2-1	Headers .....
7-2-2	Parameters .....
7-2-3	Data Formats .....
7-3	Commands and Responses for the Support Board .....
7-3-1	Command Codes .....
7-3-2	DATA LINK START .....
7-3-3	DATA LINK STOP .....
7-3-4	CONTROLLER DATA READ .....
7-3-5	CONTROLLER STATUS READ .....
7-3-6	NETWORK STATUS READ .....
7-3-7	DATA LINK STATUS READ .....
7-3-8	ECHOBACK TEST .....
7-3-9	BROADCAST TEST RESULTS READ .....
7-3-10	BROADCAST TEST DATA SEND .....
7-3-11	ERROR LOG READ .....
7-3-12	ERROR LOG CLEAR .....
7-4	Response Codes .....
7-4-1	Configuration .....
7-4-2	Network Relay Errors .....
7-4-3	Response Codes and Troubleshooting .....

## 7-1 Introduction

A message service is a command/response system used for data transmission between nodes on a network, i.e., PC to PC, PC to computer, and computer to PC. The message service can also be used to control operations, such as mode changes. The message service is implemented by executing from the user program the library functions or driver calls for sending or receiving messages.

### 7-1-1 Message Service Specifications

Communications from an computer are executed according to the specifications shown in the following table.

Item	Specifications
Direction of transmission	1:1 Message transmission or reception 1:N Message transmission (broadcast)
Data length	2,012 bytes max. (including FINS header)
Data content	Any command/response data can be sent or received. Depends on the message being sent.

### 7-1-2 Functions and Library Calls

FINS commands can be sent to specified nodes and FINS responses can be received by executing the *clksend/clkrecv/clkrcvw* library functions or the 01/02 driver calls from the user program to send and receive messages.

Functions/driver calls	Features
Sending Messages <i>clksend</i> library function and 01 driver call (See note.)	This library function and driver call send command/response data. Can be issued with respect to any Units at a PC, or to the Support Board or user program at a computer. Mainly used for sending FINS commands and responses. The FINS commands and responses enable various types of control, and allow the status to be read. Fixed-format data is prepared by the program and sent by executing <i>clksend</i> or 01. No special program is required at the receiving end if FINS commands and responses supported by the receiving Unit are used. When sending data to the computer with a user program, a program that can process the received data is required. When a response to a command is returned, a program for reading and analyzing the response is required.
Receiving Messages <i>clkrecv</i> and <i>clkrcvw</i> library functions and 02 driver call	These library functions and driver call receive command/response data. Data received by the Controller Link Support Board is read. Mainly used for receiving FINS commands and responses. The FINS commands and responses enable various types of control, and allow the status to be read. Data is received by executing <i>clkrecv</i> , <i>clkrcvw</i> , or 02, and it is analyzed by the program according to a fixed format. A program is required for analyzing the data that is received. A program is required for preparing and sending responses when commands requesting responses are received.

**Note** Using *clksend* or 01 to send the “MEMORY AREA READ” and “MEMORY AREA WRITE” FINS commands for PCs is equivalent to executing the SEND and RECV ladder-diagram instructions.

**SEND/RECV/CMND**

SEND(192), RECV(193), and CMND(194) can be employed when using CV-series PC Controller Link Units. SEND(90) and RECV(98) can be used with C200HX/HG/HE PCs, but CMND(194) cannot.

Command	Features
SEND(192)	<p>SEND is used to transfer data from any memory area at the source node to another node, and write the data to any memory area at that node.</p> <p>When SEND is executed, transmission and reception are processed automatically.</p> <p>There is no need to prepare data in any special format.</p> <p>When SEND is addressed to the CPU Unit, there is no need for any special program at the CPU Unit.</p>
RECV(193)	<p>RECV is used to transfer data to the source node from any memory area at a destination node, and write it to any memory area at the source node.</p> <p>When RECV is executed, transmission and reception are processed automatically.</p> <p>There is no need to prepare data in any special format.</p> <p>When RECV is addressed to the CPU Unit, there is no need for any special program at the CPU Unit.</p>
CMND(194)	<p>CMND(194) is used to issue any command.</p> <p>Can be issued with respect to any Units at the PC, or to the Support Board or user program at the computer.</p> <p>Mainly used for sending and receiving FINS commands and responses. The FINS commands and responses enable various types of control, and allow the status to be read.</p> <p>When CMND(194) is executed, transmission and reception are processed automatically, but fixed-format data must be prepared and analyzed.</p> <p>When sending data to the computer with a user program, a program that can process the received data is required.</p> <p>Although CMND(194) can only be issued by CV-series and CS1-series PCs, they can be received and responded to by C200HX/HG/HE PCs.</p>

**7-1-3 Using the Message Service**

The following diagrams show how the message service is used, depending on the sending and receiving nodes.

Direction	Data transmission	Control by command
Computer to PC	<p>Library function or driver call for sending message + FINS command for reading to or writing from receive area.</p>	<p>Units that support FINS commands and responses (See note)</p> <p>Library function or driver call for receiving message + any FINS command.</p>
PC to Computer	<p>SEND or RECV</p> <p>Library function or driver call for receiving message</p> <p><b>Note:</b> At the computer, a response must be returned by the user program in the proper format.</p>	<p>CMND(194) + any FINS command</p> <p>Controller Link Support Board</p>

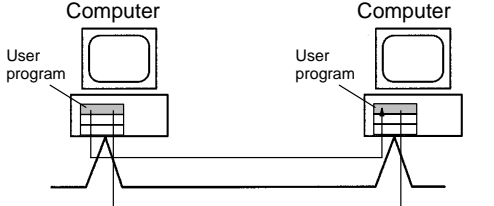
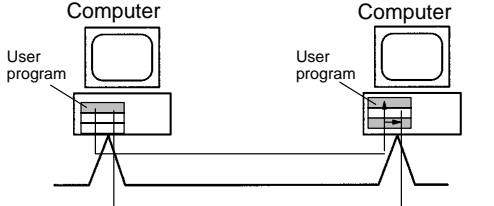
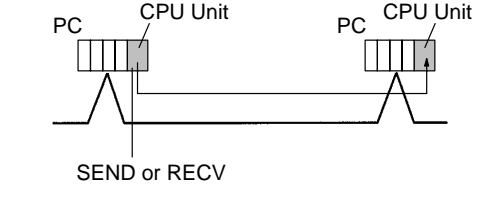
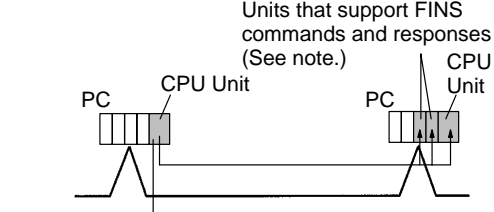
Direction	Data transmission	Control by command
Computer to Computer	 <p>Library function or driver call for sending message + FINS command for reading to or writing from receive area.</p> <p>Library function or driver call for receiving message</p> <p><b>Note:</b> At the computer, a response must be returned by the user program in the format requested by the sender.</p>	 <p>Library function or driver call for receiving message + any FINS command.</p> <p>Controller Link Support Board</p>
PC to PC	 <p>SEND or RECV</p>	 <p>Units that support FINS commands and responses (See note.)</p> <p>CMND(194) + any FINS command</p>

**Note** Commands cannot be issued to C200HX/HG/HE Units that are not directly connected to the network.

### 7-1-4 Message Service Processing

The message service can be received and processed at the two places shown in the following table when a Controller Link Support Board is mounted to the computer.

Item	Receiving unit address	Message service functions
Support Board	10 to 1F (Hex): 10 (Hex) + Unit number or FE (Hex): Support Board at specified node of specified network	FINS commands and responses for the Controller Link Support Board (Processing is carried out automatically in the Support Board, and a response is automatically returned.)
User program	01 (Hex)	Any command (Commands that are received are processed by the user program, and responses are returned as required.)

- Note**
1. The unit address is the unit number plus 10 (Hex).
  2. Set the unit number for the Support Board either when installing or as a Controller Link BIOS option.

### 7-1-5 FINS Commands for the Support Board

Command code		Name	Page
04	01	DATA LINK START	131
	02	DATA LINK STOP	132
05	01	CONTROLLER DATA READ	132
06	01	CONTROLLER STATUS READ	133
	02	NETWORK STATUS READ	135
	03	DATA LINK STATUS READ	136
08	01	ECHOBACK TEST	137
	02	BROADCAST TEST RESULTS READ	138
	03	BROADCAST TEST DATA SEND	138
21	02	ERROR LOG READ	139
	03	ERROR LOG CLEAR	140

## 7-2 FINS Command/Response Format

This section explains the format of the FINS commands and responses specified by the "clksend" library function and "01" driver call.

When actually sending or receiving message service data, the contents specified by the library function or driver call parameters are attached as a header. When the message service is used, however, there is normally no need to pay special attention to headers.

### 7-2-1 Headers

Although parameters are used to designate the source, the destination, and other required information, there are some cases where a header must be manually added before the command code. Refer to the operation manuals for individual systems to determine if a header is required. The header format described below is attached before the command code and the other parameters described for individual commands in the rest of this manual.

#### Command Data Structure

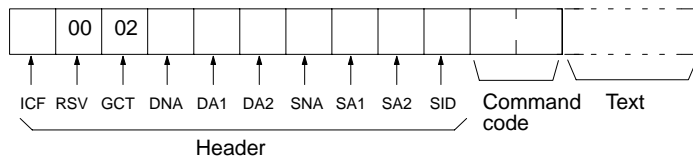

#### Response Data Structure

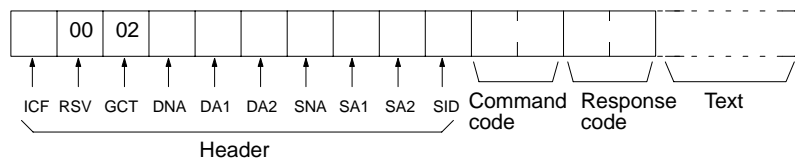

### Details

#### ICF

Information control field. Individual bits of the ICF are used as follows:

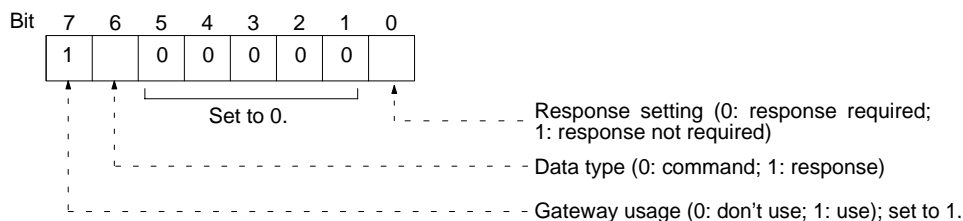



**Note** All settings below are shown in hexadecimal except where otherwise indicated.

- RSV** Reserved. Set to 00.
- GCT** Gateway count. Set to 02.
- DNA** Destination network address. Specify within the following ranges.  
 00: Local network  
 01 to 7F: Remote network (1 to 127 decimal)
- DA1** Destination node number. Specify within the following ranges.  
 01 to 20: Node number in Controller Link network (1 to 32 decimal)  
 01 to 7E: Node number in SYSMAC NET network (1 to 126 decimal)  
 01 to 3E: Node number in SYSMAC LINK network (1 to 62 decimal)  
 FF: Broadcast transmission
- DA2** Destination unit address. Specify within the following ranges. (For computers, 10 Hex is added to the unit number for the Support Board.)  
 00: PC (CPU Unit)  
 01: User program  
 10 to 1F: Board for CPU Bus Unit or computer  
 FE: Unit or Board connected to specified network  
 (Any Unit or Board in Controller Link, SYSMAC NET, or SYSMAC LINK network)
- SNA** Source network address. Specify within the following ranges.  
 00: Local network  
 01 to 7F: Remote network (1 to 127 decimal)
- SA1** Source node number. Specify within the following ranges.  
 01 to 20: Node number in Controller Link network (1 to 32 decimal)  
 01 to 7E: Node number in SYSMAC NET network (1 to 126 decimal)  
 01 to 3E: Node number in SYSMAC LINK network (1 to 62 decimal)
- SA2** Source unit address. Specify within the following ranges.  
 00: PC (CPU Unit)  
 01: User program  
 10 to 1F: Board for CPU Bus Unit or computer
- SID** Service ID. Used to identify the processing generating the transmission. Set the SID to any number between 00 and FF

### 7-2-2 Parameters

All parameters are specified in hexadecimal unless otherwise specified. Where decimal is specified, it is indicated by BCD.

### 7-2-3 Data Formats

#### Commands

The command code and text for the command are stored in memory as operands and the transmission is executed using the required parameters. The specific method depends on the programming method being used. Prepare the transmission data from the command code to the end of the text (with the data determined by the individual command), and execute the library function or driver call for message transmission. There are two bytes available for the command code and 0 to 2,000 bytes for the text.

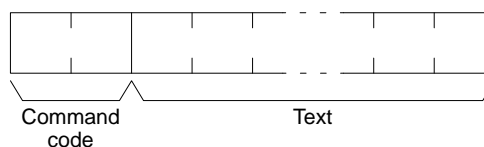

**Responses**

When the library function or driver call for message reception is executed, the data from the command code to the end of the text (with the data determined by the individual command) is stored as reception data, as shown in the following diagram. There are four bytes available for the command code and response code, and 0 to 1,998 bytes for the text.

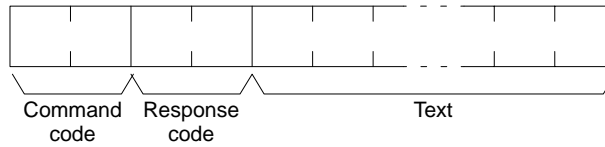

**Note** When multiple networks are connected, there are limits to the amount of data that can be transmitted or received via the Controller Link Network and the host link function.

## 7-3 Commands and Responses for the Support Board

### 7-3-1 Command Codes

Command code	Data link operation mode		Name	Page
	Active	Inactive		
04	01	Not valid	DATA LINK START	131
	02	Valid	DATA LINK STOP	132
05	01	Valid	CONTROLLER DATA READ	132
06	01	Valid	CONTROLLER STATUS READ	133
	02	Valid	NETWORK STATUS READ	135
	03	Valid	DATA LINK STATUS READ	136
08	01	Valid	ECHOBACK TEST	137
	02	Valid	BROADCAST TEST RESULTS READ	138
	03	Valid	BROADCAST TEST DATA SEND	138
21	02	Valid	ERROR LOG READ	139
	03	Valid	ERROR LOG CLEAR	140

### 7-3-2 DATA LINK START

Starts the Controller Link Network data links.

**Command Block**

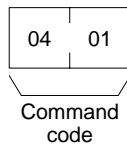

**Response Block**

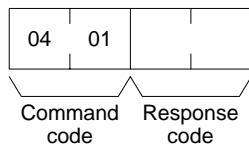

The DATA LINK START command can be received for manually set data links. An error will occur if manually set data links are specified and yet data link tables do not exist.

The node that receives this command and starts the data links will become the data link startup node.

**Note** The Support Board can participate in automatically set data links, but it cannot be the starting unit.

### 7-3-3 DATA LINK STOP

Stops the Controller Link Network data links.

#### Command Block

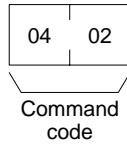

#### Response Block

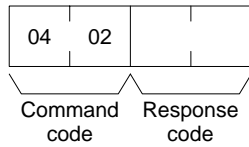

The DATA LINK STOP command can be received only while the data links is active. An error will occur if this command is sent at any other time.

This command can be received by any node that is participating in the data link.

### 7-3-4 CONTROLLER DATA READ

Reads the Controller Link Support Board's model, version, and node address data.

#### Command Block

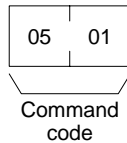

#### Response Block

3G8F5-CLK21-E (Wired Controller Link Support Board)

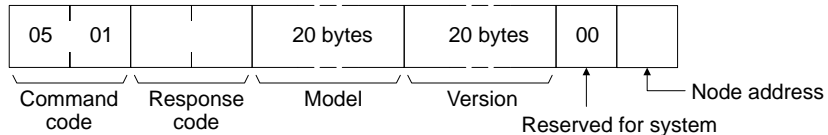

3G8F5-CLK11-E (Optical Controller Link Support Board)

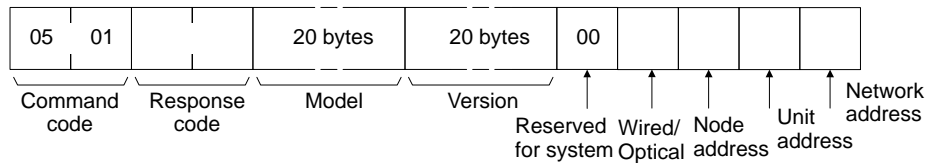

#### Parameters

**Model, version (response):** The Controller Link Unit's model and version are returned as shown below, each 20 characters in ASCII code. If fewer than 20 bytes of data are used, 20 (Hex) (i.e., spaces) will be returned for the remaining bytes. In the version numbers shown below, the spaces are represented by boxes (□).

#### Model

Controller Link Support Board: 3G8F5-CLK01□□□□□□□□□□ (Wired)  
 3G8F5-CLK02□□□□□□□□□□ (Optical)

#### Version

V1.00□V1.00□□□□□□□□□□

The first "V1.00" represents the Support Board version number, and the second represents the Communications Controller version number.

**Node address (response):** The Support Board's node address is returned between 01 and 20 Hex (1 to 32).

**Wired/Optical (response)**

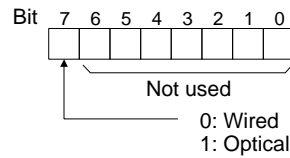

**Unit address (response):** The Support Board's Unit address is returned between 10 and 1F Hex.

**Network address:** The Support Board's network address is returned between 00 and 7F Hex (0 to 127).

### 7-3-5 CONTROLLER STATUS READ

Reads the Controller Link Support Board's controller status.

#### Command Block

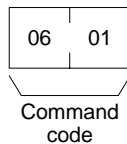

#### Response Block

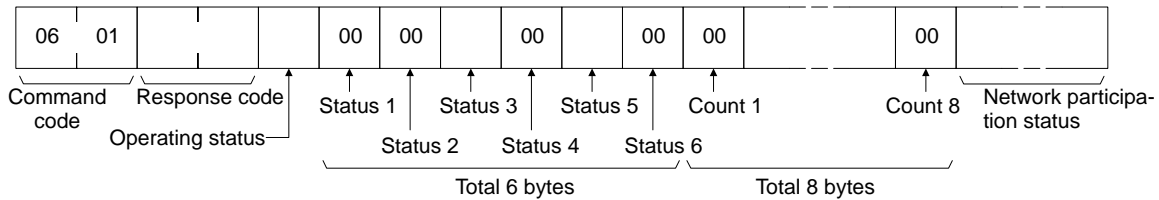

#### Parameters

**Operating status (response):** The operating status of the data links is as follows:

- 00 (Hex): Data links inactive.
- 01 (Hex): Data links active.
- 02 (Hex): Local data links not active. (The data links are active in the network, but the source node is not participating.)

**Status 1, Status 4, Status 6 (response):** Not used by Controller Link. Always set to 00 (Hex).

**Status 2:** This byte contains the following information for Optical Controller Link Support Boards. (It is always 00 Hex for Wired Controller Link Support Boards.)

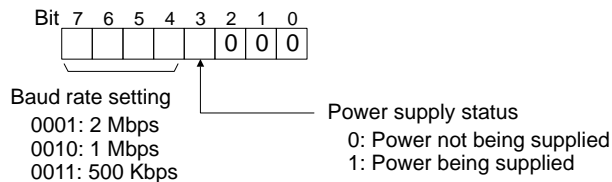

**Status 3 (response):** Error information. The configuration is as follows:

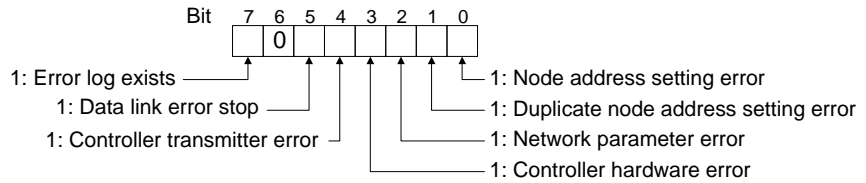

**Note** A network parameter error occurs if the registered network parameter contents do not match the actual network parameter contents after the power is turned on. The system, however, will not stop. When a network parameter error occurs, the actual network parameter contents are automatically registered to that Unit.

**Status 5 (response):** Error information related to the Support Board and the PC. The configuration is as follows:

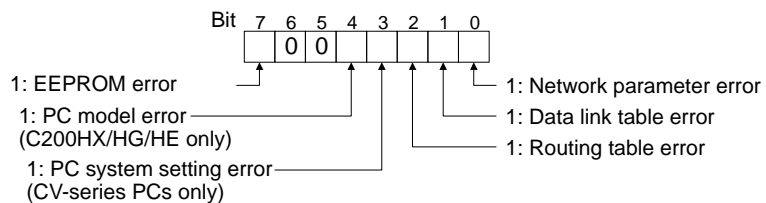

A network parameter error, data link table error, or routing table error occurs if an error is discovered when the parameters and tables are checked at power up.

A PC system setting error occurs if the Controller Link Unit is not properly recognized by a CV-series PC.

A PC model error occurs if a C200HX/HG/HE Controller Link Unit is mounted to another type of PC.

**Count 1 to Count 8 (response):** The total number of times for each of the items listed below is returned as 1 byte of hexadecimal data. The count can range from 0 to 255 (i.e., 0 to FF in hexadecimal).

- Count 1: Number of CRC errors
- Count 2: Number of token re-sends
- Count 3: Number of token returns
- Count 4: Number of token timeouts
- Count 5: Number of polling timeouts
- Count 6: Number of controller changes
- Count 7: Number of active node changes
- Count 8: Reserved for system use.

**Network participation status (response):** The following diagram shows the bits corresponding to node addresses in the Controller Link Network. When a bit is returned as "1," it means that the corresponding node is active (i.e., participating) in the network.

Bit	7	6	5	4	3	2	1	0
Byte 1	8	7	6	5	4	3	2	1
Byte 2	16	15	14	13	12	11	10	9
Byte 3	24	23	22	21	20	19	18	17
Byte 4	32	31	30	29	28	27	26	25
Byte 5	-	-	-	-	-	-	-	-
Byte 6	-	-	-	-	-	-	-	-
Byte 7	-	-	-	-	-	-	-	-
Byte 8	-	-	-	-	-	-	-	-

Reserved for system use.

The numbers in the boxes indicate the node addresses. The bit status of a particular node address shows whether or not that node is participating in the network.

- 0: Not part of network
- 1: Part of network

(All boxes marked by "-" are reserved for system use and fixed at "0.")

### 7-3-6 NETWORK STATUS READ

Reads the operating status of the entire Controller Link Network.

#### Command Block

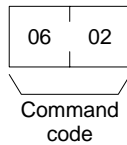

#### Response Block

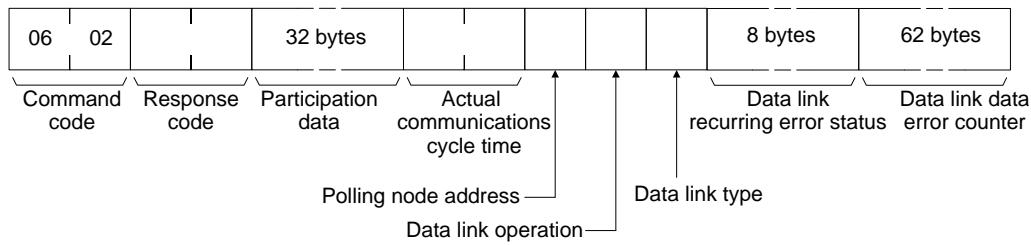

#### Parameters

**Participation data (response):** This parameter indicates the active status of individual nodes with respect to the network (i.e. their participation in the network). As shown in the following diagram, that status is expressed in four bits corresponding to the node address.

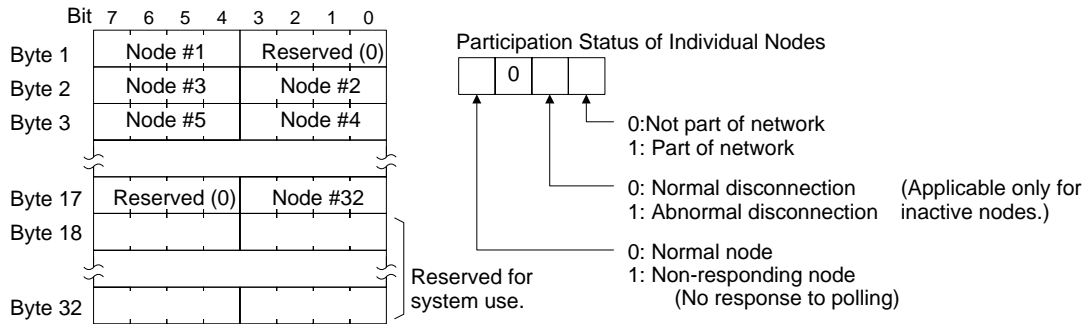

**Actual communications cycle time (response):** The actual communications cycle time is returned in units of 100  $\mu$ s in hexadecimal.

**Polling node address:** The current polling node address is returned in hexadecimal.

**Data link operation (response):** Indicates the status of data link operation in the network.

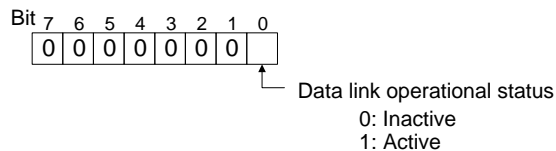

**Data link type (response):** Indicates the data transmission status of the source node's data links. It is configured as shown in the following diagram. This parameter is valid only during data link operation. While data link operation is inactive, the value from the previous operation is retained.

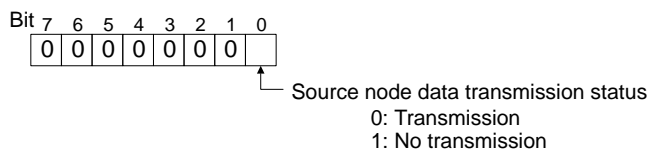

**Data link recurring error status (response):** Indicates whether an error continues to occur at a node when data link data is received. If an error continues to occur at the same node when the data is received, the bit corresponding to that node turns to “1” (i.e., turns ON). The configuration is shown in the following diagram.

Bit	7	6	5	4	3	2	1	0
Byte 1	8	7	6	5	4	3	2	1
Byte 2	16	15	14	13	12	11	10	9
Byte 3	24	23	22	21	20	19	18	17
Byte 4	32	31	30	29	28	27	26	25
Byte 5	-	-	-	-	-	-	-	-
Byte 6	-	-	-	-	-	-	-	-
Byte 7	-	-	-	-	-	-	-	-
Byte 8	-	-	-	-	-	-	-	-

Reserved for system use.

The numbers in the boxes indicate the node addresses. The bit status of a particular node address shows whether or not there is a recurring data link error at that node.

0: No recurring error  
1: Recurring error

**Data link data error counter (response):** The total number of data link data reception errors occurring at all nodes (node addresses 1 to 32) is returned as a total count from the time the power was turned on. It is expressed, in hexadecimal, as one byte per node. The count can range from 0 to 255 (i.e., 0 to FF in hexadecimal).

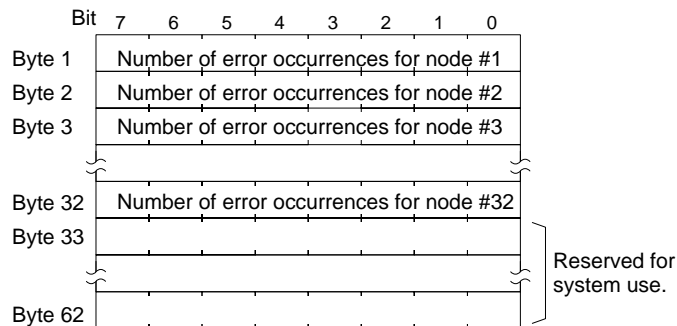

### 7-3-7 DATA LINK STATUS READ

Reads the data link operational status.

#### Command Block

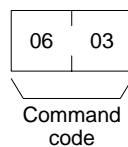

#### Response Block

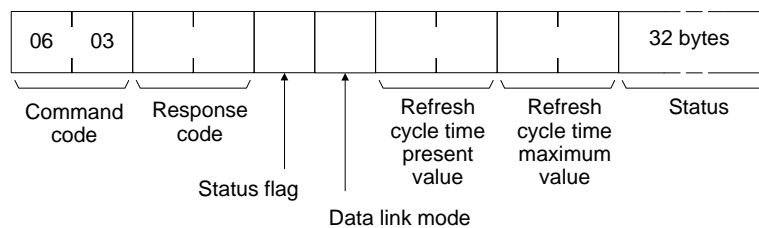

Parameters

**Status flag (response):** The overall data link status is returned in one byte of data, as shown in the following diagram.

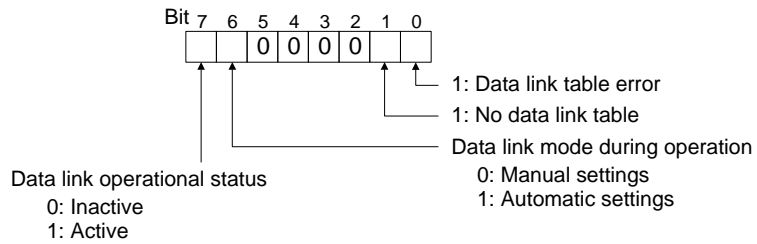

**Data link mode (response):** The data link mode during operation is returned in one byte of data, as follows:

- 01 (Hex): Automatic
- 03 (Hex): Manual

**Refresh cycle time present value, refresh cycle time maximum value (response):** The present value and the maximum value of the cycle time for refreshing the data link area are both returned in units of 1 ms, in hexadecimal, within a range of 0000 to 00FF (decimal: 0 to 255). With the Support Board, both the present value and the maximum value will be 0.

**Status (response):** The data link status of each mode is returned as shown in the following diagram. It is the same as the data link status in the PC. (Refer to page 122.)

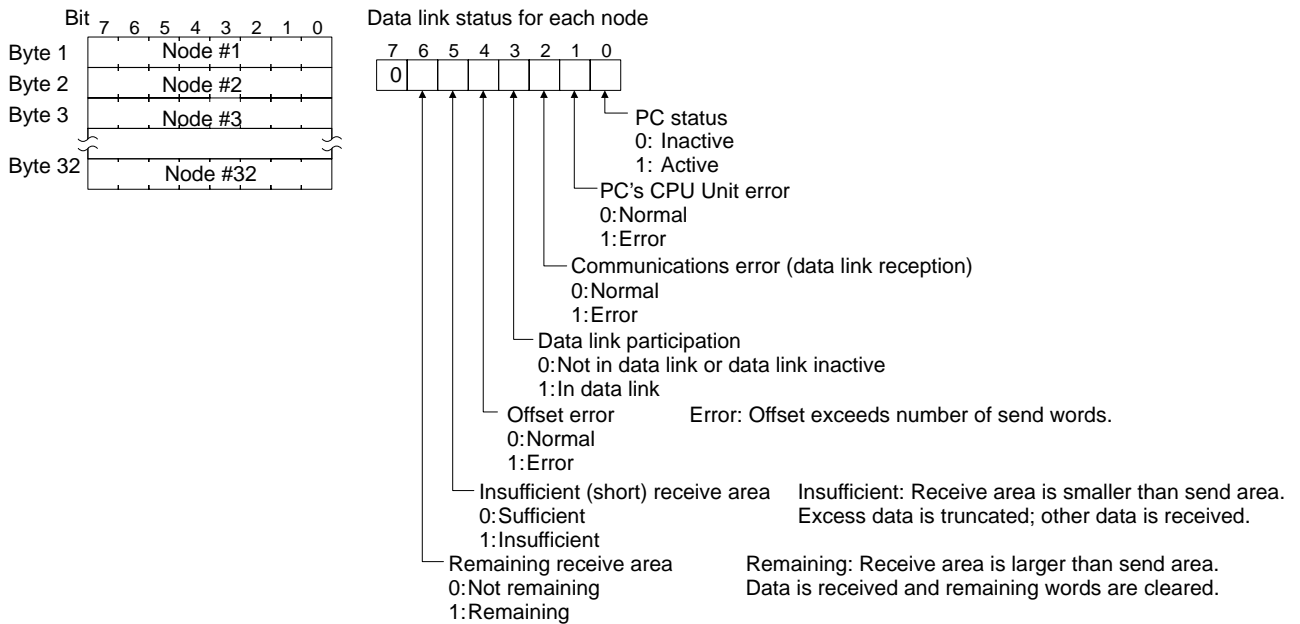

- Note**
1. The data link status is not refreshed while the data links are inactive.
  2. Nodes which are not active in the network or participating in the data links will generate communications errors.
  3. Any node which is not active in the network retains the status that existed immediately prior to the generation of the communications error.
  4. Only the PC operation status and PC error status will be refreshed for nodes that are not participating in a data link that is active in the network.

7-3-8 ECHOBACK TEST

Executes an echoback communications test between specified nodes.



**Command Block**

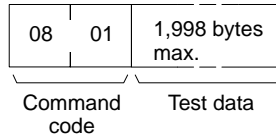

**Response Block**

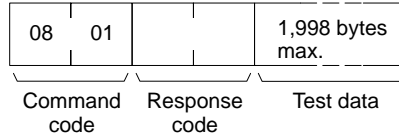

**Parameters**

**Test data (command, response):** For the command, up to 1,998 bytes of data can be specified to be sent to a specified node. For the response, the test data that was sent by the command is returned unchanged.

An error is generated if the data returned by the response is different from the data that was sent by the command.

**7-3-9 BROADCAST TEST RESULTS READ**

Reads for each node the results (number of receptions) of a BROADCAST TEST DATA SEND command that has been sent to all nodes in a specified network. (For details on the BROADCAST TEST RESULTS SEND command, refer to 7-3-10 BROADCAST TEST DATA SEND.

**Command Block**

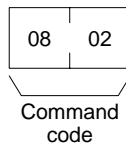

**Response Block**

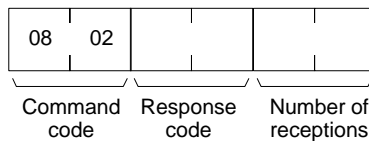

**Parameters**

**Number of receptions (response):** The number of times that broadcast test data has been received at the command destination node from the time that the last BROADCAST TEST RESULTS READ command was sent until this one was sent is returned.

An error will be generated if that number of receptions differs from the number of times that the BROADCAST TEST DATA SEND command was issued during that same period.

The *number of receptions* value being retained at the destination node is cleared when the BROADCAST TEST RESULTS READ command is executed.

**7-3-10 BROADCAST TEST DATA SEND**

Broadcasts test data to all nodes in a specified network.

**Command Block**

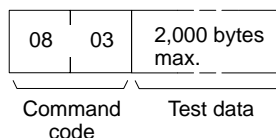

There is no response to this command.

The control data must be set as follows when this command is issued:

Destination node address: FF (Hex) (for broadcasting the data)

Destination unit address: FE (Hex)  
(for the Controller Link Support Board or Unit)

Response required/not required flag: 1 (response not required)

The transmission and reception status is checked by comparing the number of times this command is issued with the *number of receptions* parameter of the BROADCAST TEST RESULTS READ command. (For details, refer to 7-3-9 BROADCAST TEST RESULTS READ.

### 7-3-11 ERROR LOG READ

Reads the PC's error log.

#### Command Block

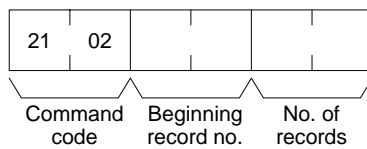

#### Response Block

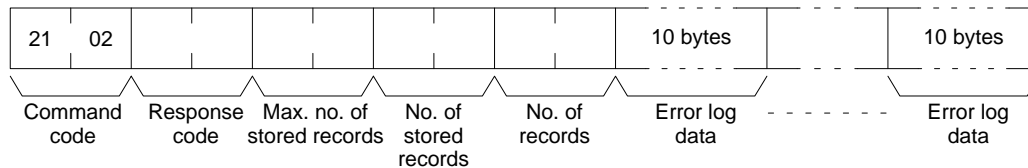

#### Parameters

**Beginning record no. (command):** Specifies the first record to be read, in two bytes (four digits) in hexadecimal. (The first record number is 0000 in hexadecimal).

**No. of records (command and response):** Specifies the number of records to be read, within a range of 0001 to 0027 in hexadecimal (decimal: 1 to 39).

**Max. no. of stored records (response):** Specifies the maximum number of records that can be recorded, within a range of 0001 to 0027 in hexadecimal (decimal: 1 to 39).

**No. of stored records (response):** The number of records that have been recorded by the time the command is executed. For the Controller Link Support Board this is fixed at 0027 Hex (decimal: 39.)

**Error log data (response):** The specified error log records are returned in sequence starting from the beginning record number. The total number of bytes required is calculated as follows:

$$\text{No. of records} \times 10 \text{ bytes}$$

The configuration of each error record is as follows:

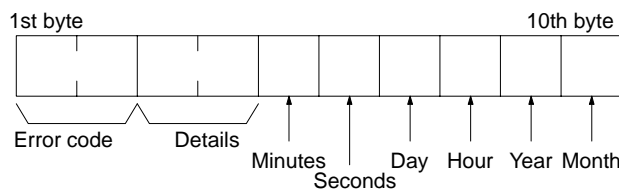

**Error code, details:** These parameters show the contents of errors. For details, refer to 10-3-2 Error Codes.

**Date and time:** These parameters show the seconds, minutes, hour (0 to 23), date, month, and year (the rightmost two digits) in BCD specifying the time that the error occurred.

**Note** If the PC does not have the specified number of records, all the records that have been stored in the PC up to the point that the command is executed will be returned.

### 7-3-12 ERROR LOG CLEAR

Clears all error log records and sets the error log pointer to 0.

#### Command Block

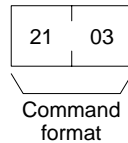

#### Response Block

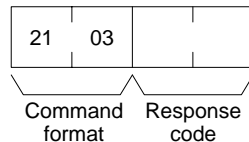

## 7-4 Response Codes

This section describes the response codes returned with responses to FINS commands. Response codes can be used to confirm normal completion of command execution or to troubleshoot problems when commands fail. For further troubleshooting information, refer to *Section 10 Troubleshooting and Maintenance* of this manual and to the operation manuals for specific Units or Systems.

### 7-4-1 Configuration

Response codes for FINS commands consist of two bytes that indicate the result of executing a command. The structure of the response codes is shown in the following diagram.

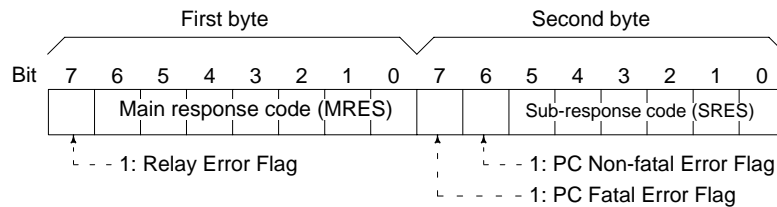

The main response code (MRES) in the first byte classifies the response and the sub-response code (SRES) in the second byte indicates details under the MRES classification.

If bit 7 of the first byte is ON, a network relay error has occurred. Refer to 7-4-2 *Network Relay Errors* for details on troubleshooting the error.

If bit 6 or 7 of the second byte is ON, an error has occurred in the PC or computer returning the response. Refer to the operation manual for the device returning the response for details when troubleshooting the error.

### 7-4-2 Network Relay Errors

A network relay error will occur whenever a command cannot reach the destination. These errors can occur for several reasons: 1) Data was not successfully

passed between two Link Units, 2) Data was not passed successfully between a Link Unit and another Unit, such as the PC's CPU Unit, or 3) The destination of a gateway does not exist. In any case, the Unit that was not able to transfer data will return a response indicating a network relay error.

Bit 7 of the first byte of the response code will be ON if a network relay error has occurred. When this happens, two more bytes of data will follow the response code to indicate the location of the error. This information, along with the response code, should enable you to track the error.

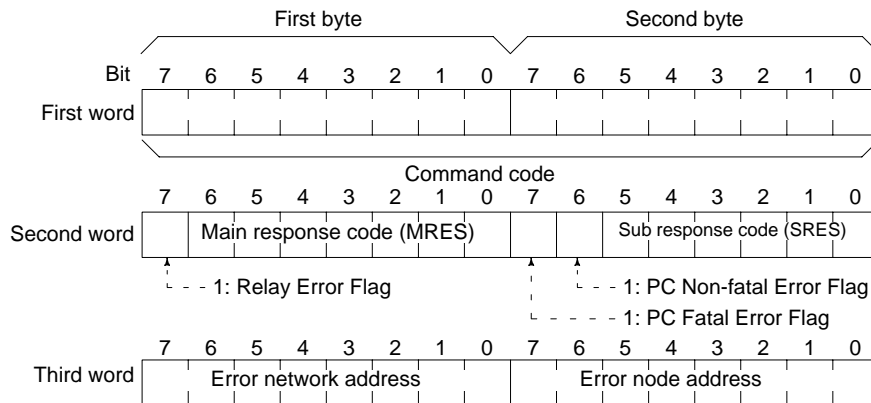

- Error network address: 00 to 7F (Hex) (0 to 127 in decimal)
- Error node address:
  - Controller Link: 01 to 20 (Hex) (1 to 32 in decimal)
  - SYSMAC NET: 01 to 7E (Hex) (1 to 126 in decimal)
  - SYSMAC LINK: 01 to 3E (Hex) (1 to 62 in decimal)

**Relay Errors**

A relay error indicates that the command did not reach the Unit to which it was sent. There are two types of situation in which this can occur. Example 1 (below) shows a situation in which a relay error occurs when data cannot be transferred from one Communications Unit to another in an interconnected network. In Example 2, the relay error occurs because either the specified destination node or the next relay node does not exist.

In the two diagrams, the numbers indicate the following:

- (1) The transmitted data fails to be received.
- (2) The relay error and response code are returned to the command source.

**Example 1**

In this example, data cannot be transferred between Controller Link Units due to some cause such as a routing table error.

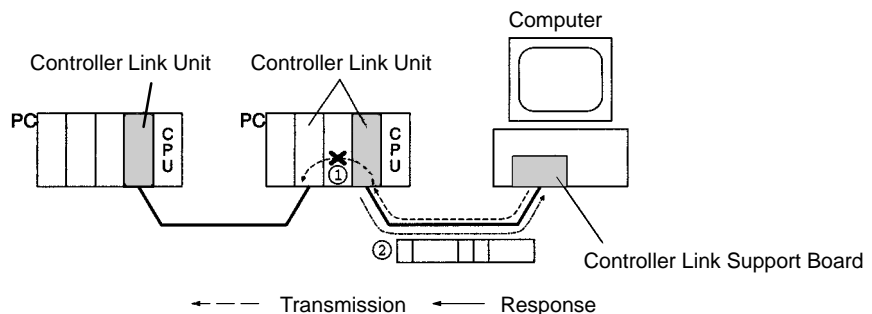

**Example 2**

In this example, the specified destination node or the next relay node does not exist.

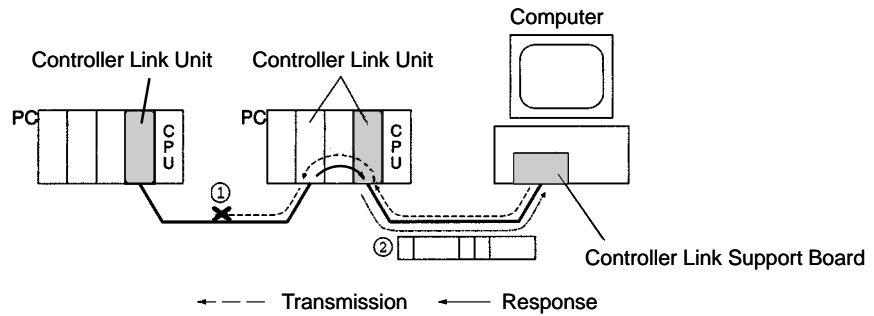

If an error occurs, check the MRES and SRES codes for the node in question, and correct the problem.

### 7-4-3 Response Codes and Troubleshooting

The table below lists response codes (main and sub-codes) returned after execution of the FINS commands, the probable cause of errors, and recommended remedies.

Upon receipt of some commands, the destination node will issue a request to another node; the other node is referred to as the third node.

Main code	Sub-code	Probable cause	Remedy
00: Normal completion	00	---	---
	01	Service was interrupted	Check the contents of the destination transmission area of third node. Check the data link status.
01: Source node error	01	Source node not part of Network	Add to Network.
	02	Token time-out, node address too large	Set the source node's node address below the maximum node address.
	03	Number of transmit retries exceeded	Check communications with echoback test. If the test fails, check network.
	04	Maximum number of frames exceeded	Either check the execution of events in the network and reduce the number of events occurring in one cycle, or increase the maximum number of frames.
	05	Node address setting error (range)	Correctly set the Controller Link BIOS /N option. Make sure the node address is within specified range and that there are no node addresses that are set twice.
	06	Node address duplication error	Make sure that there are no node addresses that are set twice.

Main code	Sub-code	Probable cause	Remedy
02: Destination node error	01	Destination node not part of Network	Add to Network.
	02	No node with the specified node address	Check the destination node's node address.
	03	Third node not part of Network	Check the third node's node address.
		Broadcasting was specified.	Check the control data and specify only one node as the third node.
	04	Busy error, destination node busy	Increase the number of transmit retry attempts or re-evaluate the system so that the destination node is not so busy receiving data.
	05	Response time-out, message packet was corrupted by noise	Increase the number of transmit retry attempts.
		Response time-out, response watchdog timer interval too short	Increase the value for the response watchdog timer interval in the control data.
Frame lost in transmission		Check the error log and correct the process.	
03: Communications controller error	01	Error occurred in the communications controller, ERC indicator is lit	Take corrective action, referring to communications controller errors and remedies table at end of this section
	02	CPU Unit error occurred in the PC at the destination node	Clear the error in the CPU Unit (refer to the PC's operation manuals)
	03	A controller error has prevented a normal response from being returned.	Check network communications status and reset the controller board. If the error still exists, replace the controller board.
	04	Unit address setting error	Make sure the Unit address is within the specified range and that there are no node addresses that are set twice.
04: Not executable	01	An undefined command has been used.	Check the command code and be sure that the Unit supports it.
	02	Cannot process command because the specified unit model or version is wrong.	Check the unit model and version.
05: Routing error	01	Destination node address is not set in the routing table.	Set the destination node address in the routing table.
	02	Routing table isn't registered.	Set the source nodes, destination nodes, and relay nodes in the routing table.
	03	Routing table error	Set the routing table correctly.
	04	The maximum number of relay nodes (2) was exceeded in the command.	Redesign the network or reconsider the routing table to reduce the number of relay nodes in the command.
10: Command format error	01	The command is longer than the max. permissible length.	Check the command format of the command and set it correctly.
	02	The command is shorter than min. permissible length.	Check the command format of the command and set it correctly.
	03	The designated number of data items differs from the actual number.	Check the number of items and the data, and make sure that they agree.
	04	An incorrect command format has been used.	Check the command format of the command and set it correctly.
	05	An incorrect header has been used. (The source node's relay table or relay node's local network table is wrong.)	Set the routing table correctly.

Main code	Sub-code	Probable cause	Remedy
11: Parameter error	01	A correct memory area code has not been used or Extended Data Memory is not available.	Check the command's memory area code and set the appropriate code.
	02	The access size specified in the command is wrong, or the first address is an odd number.	Set the correct access size for the command.
	03	The first address is in an inaccessible area.	Set a first address that is in an accessible area.
	04	The end of specified word range exceeds the acceptable range.	Check the acceptable limits of the data area and set the word range within the limits.
			Check the data link tables to be sure the limit to link words has not been exceeded.
	06	A non-existent program no. has been specified.	Check the program number and be sure that it is set correctly.
	09	The sizes of data items in the command block are wrong.	Check the command data and be sure that the sizes of the data items are correct.
			Check the data link tables to be sure all nodes in the refresh parameters are in the common link parameters.
	0A	The IOM break function cannot be executed because it is already being executed.	Either abort the current IOM break function processing, or wait until it is completed and execute the command.
			Check the data link tables for node addresses that have been set twice.
0B	The response block is longer than the max. permissible length.	Check the command format and set the number of items correctly.	
0C	An incorrect parameter code has been specified.	Check the command data and reenter it correctly.	
		Check the data link table file for corruption.	
20: Read not possible	02	The data is protected.	Execute the instruction again after issuing the PROGRAM AREA PROTECT CLEAR command to the PC.
		An attempt was made to download a file that is being uploaded.	Check the file name and either interrupt servicing or wait for servicing to complete before re-executing the command.
	03	The registered table does not exist or is incorrect.	Set or reset the registered table.
		Too many files open.	Close open files and re-execute the command.
	04	The corresponding search data does not exist.	---
	05	A non-existing program no. has been specified.	Check the program number and be sure that it is set correctly.
	06	A non-existing file has been specified.	Check whether the correct file name was used.
	07	A verification error has occurred.	Check whether the memory contents are correct and replace if incorrect.
Check the contents of the file. A read error may have occurred.			

Main code	Sub-code	Probable cause	Remedy
21: Write not possible	01	The specified area is read-only or is write-protected.	If the specified area is read-only, the write cannot be performed. If it is write-protected, turn off the write-protect switch and execute the instruction again.
	02	The data is protected.	Execute the instruction again after issuing the PROGRAM AREA PROTECT CLEAR command to the PC.
		An attempt was made to simultaneously download and upload a file.	Check the file name and either interrupt servicing or wait for servicing to complete before re-executing the command.
		The data link tables cannot be written manual because the Unit is set for automatic generation.	Change the data link mode to manual.
	03	The number of files exceeds the maximum permissible.	Write the file(s) again after erasing unneeded files, or use different disk or Memory Card that has free space.
		Too many files open.	Close open files and re-execute the command.
	05	A non-existing program no. has been specified.	Check the program number and be sure that it is set correctly.
	06	A non-existent file has been specified.	---
	07	The specified file already exists.	Change the name of the file and execute the instruction again.
08	Data cannot be changed.	Check the contents of the memory area being written to.	
22: Not executable in current mode	01	The mode is wrong (executing).	Check the operating mode.
		Data links are active.	Check the data link status before execution.
	02	The mode is wrong (inactive).	Check the operating mode.
		Data links are active.	Check the data link status before execution.
	03	The PC is in the PROGRAM mode.	Check the PC's mode.
	04	The PC is in the DEBUG mode.	Check the PC's mode.
	05	The PC is in the MONITOR mode.	Check the PC's mode.
	06	The PC is in the RUN mode.	Check the PC's mode.
	07	The specified node is not the control node.	Check which node is the control node.
08	The mode is wrong and the step cannot be executed.	Check whether the step has active status or not.	
23: No Unit	01	A file device does not exist where specified.	Mount the Memory Card or disk
	02	The specified memory does not exist.	Check the specifications of the installed file memory.
	03	No clock exists.	Check the model number.
24: Start/stop not possible	01	The data link tables either have not been created or are incorrect.	Set the data link tables correctly.



Main code	Sub-code	Probable cause	Remedy
25: Unit error	02	Parity/checksum error occurred because of incorrect data.	Transfer correct data into memory.
	03	I/O setting error (The registered I/O configuration differs from the actual.)	Either change the actual configuration to match the registered one, or generate the I/O table again.
	04	Too many I/O points	Redesign the system to remain within permissible limits.
	05	CPU bus error (An error occurred during data transfer between the CPU Unit and a CPU Bus Unit.)	Check the Unit, Service Boards, and cable connections and issue the ERROR CLEAR command.
	06	I/O duplication error (A rack number, unit number, or I/O word allocation has been duplicated.)	Check the system's settings and eliminate any settings that occur twice.
	07	I/O bus error (An error occurred during data transfer between the CPU Unit and an I/O Unit.)	Check the Unit, Service Boards, and cable connections and issue the ERROR CLEAR command.
	09	SYSMAC BUS/2 error (An error occurred during SYSMAC BUS/2 data transfer.)	Check the Unit, Service Boards, and cable connections and issue the ERROR CLEAR command.
	0A	Special I/O Unit error (An error occurred during CPU Bus Unit data transfer.)	Check the Unit, Service Boards, and cable connections and issue the ERROR CLEAR command.
	0D	Duplication in SYSMAC BUS word allocation.	Check and regenerate the I/O table.
	0F	A memory error has occurred in internal memory, in the Memory Card, or in Expansion DM during the error check.	<p>If the error occurred in internal memory or the EM Unit, correct the data in the command and execute it again.</p> <p>If the error occurred in a Memory Card or EM used for file memory, the file data has been corrupted. Execute the MEMORY CARD FORMAT command for the PC.</p> <p>If the above remedies do not eliminate the error, replace the faulty memory.</p>
10	Terminator not connected in SYSMAC BUS System.	Connect the terminator correctly.	

Main code	Sub-code	Probable cause	Remedy
26: Command error	01	The specified area is not protected. This response code will be returned if an attempt is made to clear protection on an area that is not protected.	The program area is not protected, so it isn't necessary to clear protection.
	02	An incorrect password has been specified.	Specify a password that is registered.
	04	The specified area is protected.	Execute the command again after executing the PROGRAM AREA PROTECT CLEAR command for the PC.
		To many commands at destination.	The destination has received more than 5 commands. Either interrupt servicing or wait for servicing to complete before re-executing the command.
	05	The service is being executed.	Execute the command again after the service has been completed or aborted.
	06	The service is not being executed.	Execute the service if necessary.
	07	Service cannot be executed from source node because the source node is not part of the data links.	Execute the service from a node that is part of the data links.
		A buffer error has prevented returning a normal response.	Reset the board. If the error persists, replace the board.
	08	Service cannot be executed because necessary settings haven't been made.	Make the necessary settings.
	09	Service cannot be executed because necessary settings haven't been made in the command data.	Check the command format of and make the necessary settings.
	0A	The specified action or transition number has already been registered.	Execute the command again using an action or transition number that hasn't been registered.
0B	Cannot clear error because the cause of the error still exists.	Eliminate the cause of the error and execute the ERROR CLEAR command.	
30: Access right error	01	The access right is held by another node.  (Either a peripheral device at the other node is executing an SFC online edit, or the other node is executing an ACCESS RIGHT ACQUIRE or ACCESS RIGHT FORCED ACQUIRE command.)	Execute the command again after the access right has been released.  (The command can be executed after the ACCESS RIGHT FORCED ACQUIRE or ACCESS RIGHT RELEASE command is completed. Releasing the access right might affect processes in progress at the node that held the access right.)
40: Abort	01	Command was aborted with ABORT command.	---

# SECTION 8

## Network Interconnections

This section describes the method used to connect multiple networks through CV-series or CS1-series PCs.

- 8-1 What is Network Interconnection? .....
- 8-1-1 Interconnecting Controller Link Networks .....
- 8-1-2 Interconnecting Different Types of Networks .....
- 8-2 Routing Tables .....
- 8-3 Setting Routing Tables .....
- 8-3-1 Routing Table Setting Procedure .....
- 8-3-2 Editing Local Network Tables .....
- 8-3-3 Editing Relay Network Tables .....
- 8-3-4 Saving Routing Tables .....
- 8-3-5 Transferring Routing Tables .....
- 8-3-6 Example Routing Table Settings .....

## 8-1 What is Network Interconnection?

Network interconnection enables commands and responses for the message service to be sent and received across multiple networks. The three networks listed below can be interconnected to achieve this.

- Controller Link Networks
- SYSMAC NET Link Networks
- SYSMAC LINK Networks

### 8-1-1 Interconnecting Controller Link Networks

Controller Link Networks can be connected through a CV-series or a CS1-series PC.

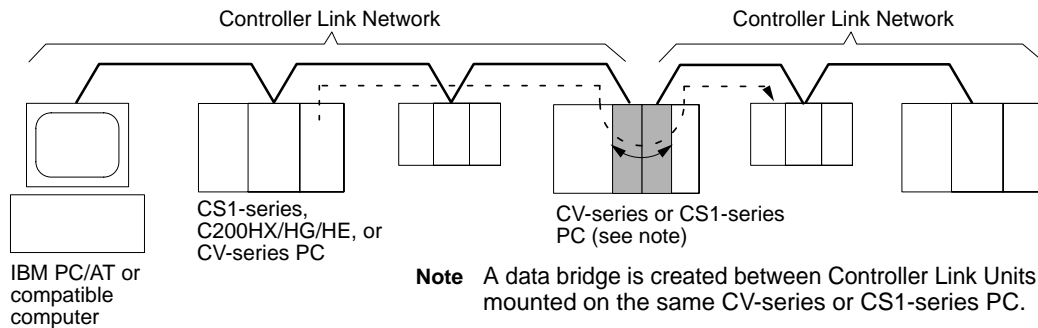

### 8-1-2 Interconnecting Different Types of Networks

A CV-series or CS1-series PC can be used to connect a Controller Link Network with a SYSMAC NET or SYSMAC LINK Network.

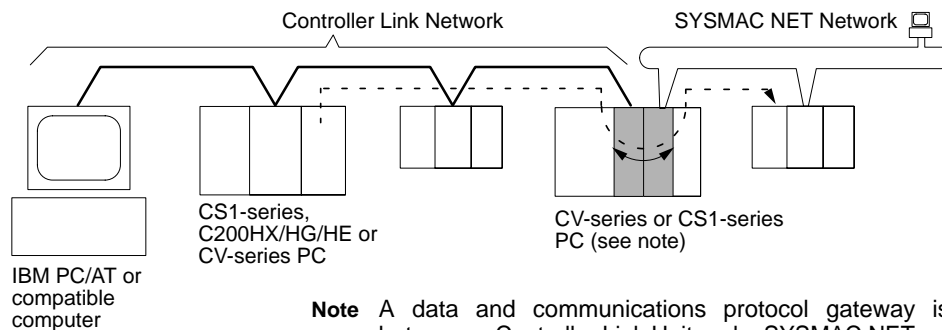

**Note** A data and communications protocol gateway is created between a Controller Link Unit and a SYSMAC NET or SYSMAC LINK Unit mounted to the same CV-series or CS1-series PC.

- Note**
1. A bridge is used between Communications Units to connect the same type of networks.
  2. A gateway is used between Communications Units to connect different types of networks.

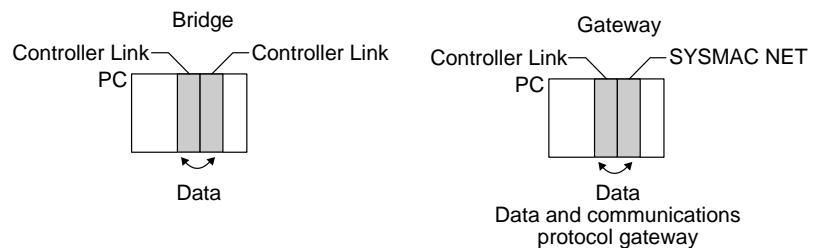

- Only one Controller Link Support Board can be mounted to an IBM PC/AT or compatible computer.

- Communications across bridges or gateways can include up to three networks, including the local network (data generating network).

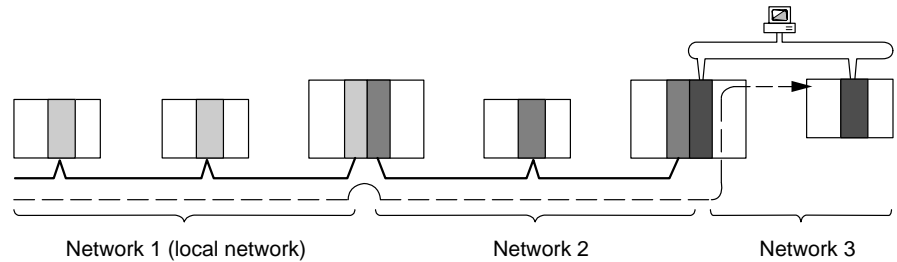

Although 2,012 bytes of data (including the header) can be sent and received with a Controller Link, the maximum amount of data is limited by any network the data passes through, i.e., the network with the the smallest capacity will determine the limit.

If, for example, data passes through a SYSMAC LINK network as shown in the figure on the preceding page, the amount of data sent and received from the Controller Link is limited to 552 bytes (including the header) because the SYSMAC LINK Network can only handle that many bytes.

See the manual for the network you are using in order to determine the maximum amount of data for each network.

## 8-2 Routing Tables

Routing tables that define the communications path from the Controller Link Unit on the local PC to the network connected to the destination PC must be created in order to send and receive data across networks.

### Creating Routing Tables

Routing tables consists of a local network table and a relay network table.

#### Local Network Table

The local network table lists the unit numbers and corresponding network addresses for the Controller Link Unit and Support Board unit numbers. With the Support Board, only one entry can be set in the table.

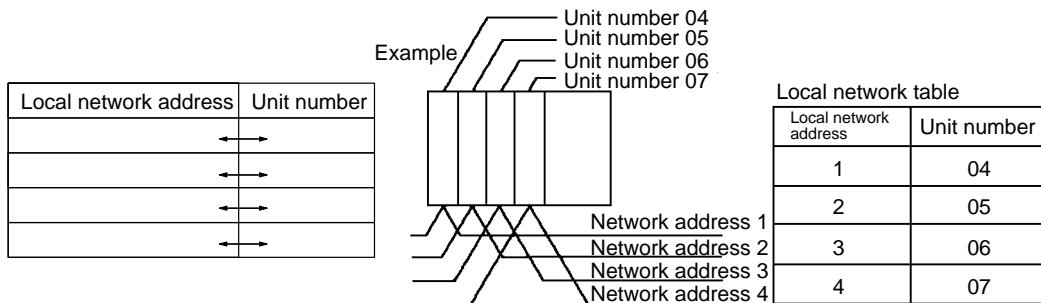

- Note**
1. The unit number is set between 00 and 15 using the rotary switch on the front panel of CV-series and CS1-series Controller Link Units, and is the same as the operating level for C200HX/HG/HE PCs. For the Support Board, it is the value set for the Controller Link BIOS in CONFIG.SYS (i.e., using the /U option).
  2. The network address is the address of the network connected to the Unit (between 1 and 127). The address is set when the local network table is created.

**Relay Network Table**

A relay network table provides the node and network addresses corresponding to the initial relay point (first point the data must go to) en route to a target network (end network) not directly connected to the local PC. The table traces the route from the relay point to the end network.

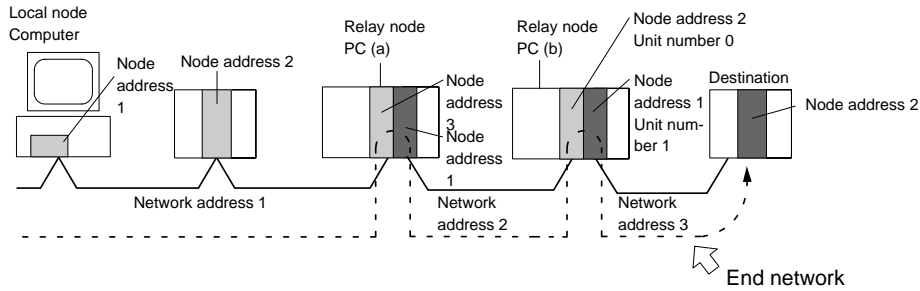

Computer relay network table

End network	Relay network	Relay node
2	1	3
3	1	3

Data first goes to node address 3 at network address 1 to reach network address 3.

PC (a) relay network table

End network	Relay network	Relay node
3	2	2

Data then goes to node address 2 at network address 2 to reach network address 3.

PC (b) local network table

Local network address	Unit number
2	0
3	1

We know from the local network table that the data goes through local unit number 1 to reach network address 3.

Data goes to node address 2 at network address 3, i.e., the local network.

## 8-3 Setting Routing Tables

This section describes routing table settings.

Routing tables are set through the Controller Link Support Software or CX-Programmer. This section describes setting procedures and setting details.

For specific operations, see the *Controller Link Support Software Operation Manual (W308)* or *CX-Programmer User's Manual*. For Controller Link Unit settings, refer to the *Controller Link Units Operation Manual (W309)*.

### 8-3-1 Routing Table Setting Procedure

The procedure for setting routing tables is described below.

- 1, 2, 3... 1. Edit the local network table.
2. Edit the relay network table.
3. Save the routing tables.
4. Transfer the routing tables.

### 8-3-2 Editing Local Network Tables

Use the Controller Link Support Software's routing table editing function to edit the local network table as shown on the screen given below.

[ Local Network table ]

No.	Loc Netuk	SIOU unit #	No.	Loc Netuk	SIOU unit #
1			9		
2			10		
3			11		
4			12		
5			13		
6			14		
7			15		
8			16		

**Local Network:** (Loc Netwk)

Address 1 through 127 for the network connected to the Support Board.

**SIOU Unit No.:** (SIOU unit #)

Controller Link Support Board unit number (0 to 15)

With the Support Board, only one entry can be set in the local network table.

The Support Board's SIOU unit number is the value set for the Controller Link BIOS by CONFIG.SYS (i.e., using the /U option).

### 8-3-3 Editing Relay Network Tables

Use the Controller Link Support Software's routing table editing function to edit the relay network table as shown on the screen given below.

[ Relay Network table ]

No.	End Netwk	PC ID	Relay Netwk	node
1				
2				
3				
4				
5				
6				
7				
8				
9				
10				

No.	End Netwk	PC ID	Relay Netwk	node
11				
12				
13				
14				
15				
16				
17				
18				
19				
20				

**End Network:** (End Netwk)

Network address of the end network (1 through 127)

**Relay Network:** (Relay Netwk)

Network address of the first relay point on the way to the end network (1 through 127)

**Relay Node:** (Relay node)

Node address of the first relay point on the way to the end network (Controller Link: 1 through 32, SYSMAC NET: 1 through 126, and SYSMAC LINK: 1 through 62)

All networks not directly connected to the local node are set.

**Note** The PC ID is any unique name given to a specific node. When setting the PC ID, simply input the ID. Network and node addresses will be input for you automatically. See the *Controller Link Support Software Operation Manual (W308)* for further details.

### 8-3-4 Saving Routing Tables

After editing the local and relay network tables, save the tables.

**Note** When setting routing tables in multiple PCs, edit and save all routing tables and then transfer them together for greater efficiency.

### 8-3-5 Transferring Routing Tables

Routing tables that have been saved can be read to the Controller Link Support Software from memory and then transferred.

### 8-3-6 Example Routing Table Settings

This section shows examples of routing table settings.

**Example 1**

The example below shows local network table settings when a Support Board is mounted to a computer.

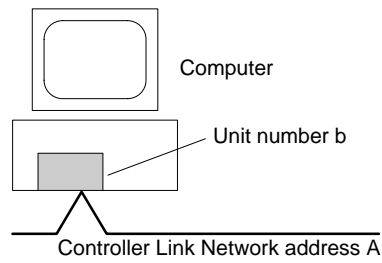

**Local Network Table**

No.	Loc Netwk	SIOU unit #
1	A	b

**Example 2**

The following example show the settings for a relay network table connecting three networks.

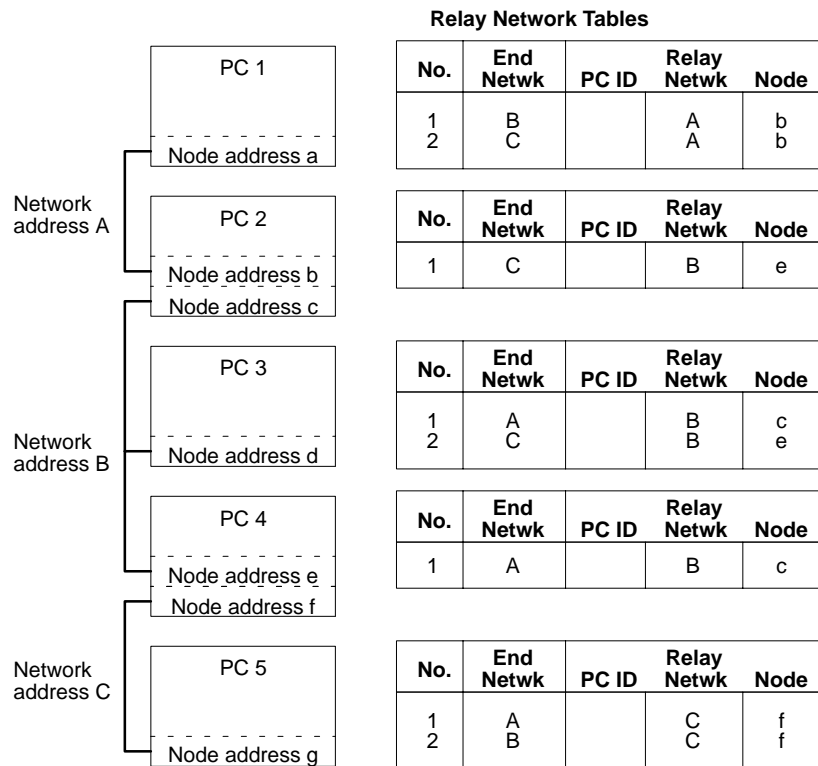

On closer examination of the relay network table for PC 3, we see that the relay network is B and the relay node is c when network A is the destination, and that the relay network is B and the relay node is e when network C is the destination.



**Example 3**

The network structure example in the figure below shows routing tables for all nodes.

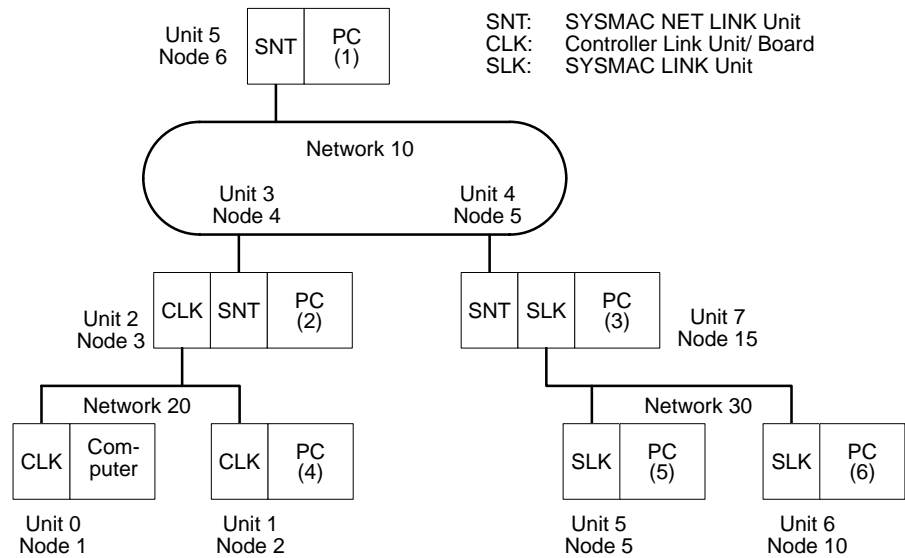

**Routing Tables on PC 1**

Local Network Table

No.	Loc Netwk	SIOU unit#
1	010	05
2		
3		

Relay Network Table

No.	End Netwk	PC ID	Relay Netwk	Node
1	020		010	004
2	030		010	005
3				

**Routing Tables on PC 2**

Local Network Table

No.	Loc Netwk	SIOU unit#
1	010	03
2	020	02
3		

Relay Network Table

No.	End Netwk	PC ID	Relay Netwk	Node
1	030		010	005
2				
3				

**Routing Tables on PC 3**

Local Network Table

No.	Loc Netwk	SIOU unit#
1	010	04
2	030	07
3		

Relay Network Table

No.	End Netwk	PC ID	Relay Netwk	Node
1	020		010	004
2				
3				

**Routing Tables on Computer**

Local Network Table

No.	Loc Netwk	SIOU unit#
1	020	00
2		
3		

Relay Network Table

No.	End Netwk	PC ID	Relay Netwk	Node
1	010		020	003
2	030		020	003
3				

**Routing Tables on PC 4**

Local Network Table

No.	Loc Netwk	SIOU unit#
1	020	01
2		
3		

Relay Network Table

No.	End Netwk	PC ID	Relay Netwk	Node
1	010		020	003
2	030		020	003
3				

**Routing Tables on PC 5**

Local Network Table

No.	Loc Netwk	SIOU unit#
1	030	05
2		
3		

Relay Network Table

No.	End Netwk	PC ID	Relay Netwk	Node
1	010		030	015
2	020		030	015
3				

**Routing Tables on PC 6**

Local Network Table

No.	Loc Netwk	SIOU unit#
1	030	06
2		
3		

Relay Network Table

No.	End Netwk	PC ID	Relay Netwk	Node
1	010		030	015
2	020		030	015
3				

# SECTION 9

## Communications Timing

This section explains details on Controller Link Network communications. Refer to this section for network communications that require accurate communications timing.

- 9-1 Network Parameters .....
- 9-1-1 Controller Link Communications .....
- 9-1-2 Communications Cycle .....
- 9-1-3 Network Parameters .....
- 9-1-4 Specifying Network Parameters .....
- 9-2 Communications Cycle Time .....
- 9-2-1 Active Data Links .....
- 9-2-2 Inactive Data Links .....
- 9-3 Data Link I/O Response Time .....
- 9-3-1 Computer to PC .....
- 9-3-2 PC to Computer .....
- 9-4 Message Service Delay Times .....

## 9-1 Network Parameters

This section explains how to use Controller Link Network communications and how to adjust the network parameters to match the system.

### 9-1-1 Controller Link Communications

The token bus method is used for communications in the Controller Link Network. With this method, a piece of data called a “token” is sent between the various nodes in the network. The only node that can transmit data at any given time is the one that currently holds the token, thereby preventing interferences to data transmission within the network.

The token travels from smaller node addresses to larger, and then back to the beginning again, without regard to the order in which the nodes are connected. If the node has data to send, it will attach the data to the token and send them together. If the node has no data to send, it will pass the token to the next node.

#### Polling Node

Each Controller Link Network always has a Unit that controls communications within the network. This Unit is called the “polling node.” Normally, the node that has the smallest node address in the network is the polling node. All Units at nodes other than the polling node are called “polled nodes.” The polling node controls the token, checks the network, and performs other relevant tasks. Should the polling node break down, the node with the next smallest node address is automatically selected as the polling node to prevent the entire network from shutting down.

### 9-1-2 Communications Cycle

The “communications cycle” is the cycle for repeating Controller Link Network processing. The time required for one communications cycle is called the “communications cycle time,” and each communications cycle is divided into a “token cycle” and a “polling cycle” as shown in the following diagram.

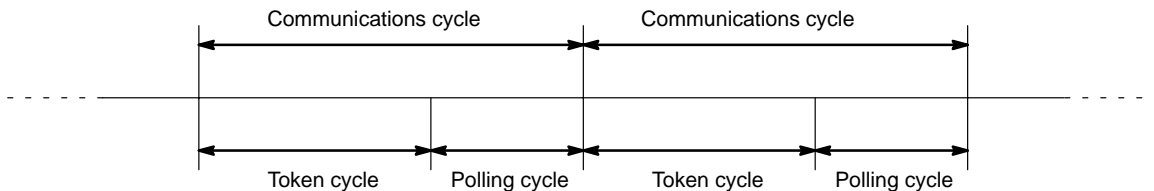

#### Token Cycle

The token cycle is the period during which the token is sent from the polling node to the nodes in order and returned to the polling node. During this cycle, any nodes with data to send will send that data. Data link data will also be sent during this cycle.

#### Polling Cycle

The polling cycle is the period during which the polling node checks the status of the nodes in the network. The polling node checks whether each node is actually participating in the network, whether there are any new nodes participating, and so on, and notifies all the nodes of the results of the check.

#### Refresh Cycle Time

The refresh cycle time is the time, during data link operation, from when the contents of the data link areas are refreshed until the next time they are refreshed. The refresh cycle time will vary depending on factors such as the communications cycle time, the number of data link words, and so on.

The refresh cycle time value can be displayed by the Controller Link Support Software’s data link status monitoring function. There is no refresh cycle time for the Support Board, because the data link areas are constantly refreshed by the data link data that is received. When the refresh cycle time for the Support Board is read by the Controller Link Support Software, therefore, the value will always be 0.

### 9-1-3 Network Parameters

Network parameters are also used to control network operations. Network parameters are read from the polling node and distributed to all other nodes when the Controller Link Network is started. In this way, all nodes on the network always have the same network parameter settings. If nodes are connected to the network halfway during network operation, the network parameter settings will also be distributed to these nodes when they are connected. The following three network parameters can be specified.

**Maximum Node Address**

This parameter specifies the maximum node address of nodes to be checked by the polling node. The default is 32. Reducing the setting of this parameter reduces the number of nodes checked by the polling node and can thus avoid unnecessary check operations. However, if the network contains nodes with node addresses greater than the setting of the parameter, these nodes will not be connected to the network.

**No. of Polled Nodes Per Communications Cycle**

This parameter specifies the number of nodes to be checked (polled) by the polling node during each polling cycle. The default is 4. Setting this parameter to a high value increases the communications cycle time, but reduces the time required to recognize that nodes have been removed from or added to the network. Reducing the setting of this parameter shortens the communications cycle time but delays a network response when a node is disconnected from or connected to the network.

**No. of Event-frames per Communications Cycle**

This parameter specifies the maximum number of event frames (communications other than data links, such as message service transmissions) that can be transferred during a communications cycle. Specify a value in units of 128 bytes. The default is 35 (128 × 35 = 4,480 bytes).

Increasing the setting of this parameter increases the communications cycle time but allows for more event communications such as the message service. Too small a parameter value restricts event communications, resulting in an error.

See 9-2 *Communications Cycle Time* for the effects of network parameters on communication cycle times.

### 9-1-4 Specifying Network Parameters

The network parameters can be specified from the Controller Link Support Software. This section describes only the allowable setting range for each network parameter. Refer to the *Controller Link Support Software Operation Manual (W308)* for setting procedures.

The following table shows the setting range and default for network parameters.

Network parameter	Setting range	Default value
Maximum node address	2 to 32	32
Number of polled nodes per communications cycle	1 to 32	4
No. of event-frames per communications cycle	16 to 238	35

The network parameters become valid immediately after being set.

- Note**
1. Always stop the data link before changing network parameters.
  2. Specify a value for the maximum node address that is equal to or greater than the maximum node address in the Controller Link Network.

## 9-2 Communications Cycle Time

This section describes how to calculate the communications cycle time. When accurate timing is required, it is necessary to understand the time required for sending and receiving data link data and the timing for exchanging data.

### 9-2-1 Active Data Links

The following equations are used to calculate the communications cycle time when data links are operating. (The communications cycle time will vary somewhat depending on the baud rate and the conditions at that particular time.)

#### Wired Systems

Baud rate	Equation
2 Mbps	$10 \times A + 600 \times B + 290 \times C + 320 \times D + 4 \times E + 3,290 \text{ (}\mu\text{s)}$
1 Mbps	$18 \times A + 1,150 \times B + 370 \times C + 360 \times D + 8 \times E + 3,770 \text{ (}\mu\text{s)}$
500 Kbps	$34 \times A + 2,260 \times B + 530 \times C + 440 \times D + 16 \times E + 4,730 \text{ (}\mu\text{s)}$

#### Optical Systems

Baud rate	Equation
2 Mbps (Fixed)	$10 \times A + 1,300 \times B + 290 \times C + 320 \times D + 4 \times E + 2 \times F + 3,290 \text{ (}\mu\text{s)}$

**Note** The meanings of the variables in the above formulas are as follows:

- A: Total number of data link words within the network (total number of words in send areas of all nodes)
- B: Number of polled nodes per comm cycle (value specified in the network parameters)
- C: Number of nodes connected to the network
- D: Number of nodes that send messages during the communications cycle
- E: Total number of bytes in messages transmitted during the communications cycle
- F: Extra communications time for long distance Optical Fiber Cable connections.  $F = 7 \times L \text{ }\mu\text{s}$  (L is the cable length in km.)

#### Calculation Example

Communications conditions are as follows:

- Baud rate: 2 Mbps
- Network parameters: Defaults
- Max node address: 32
- Polled nodes per comm cycle: 4
- Event-frames per comm cycle: 35
- Network configuration: 8 nodes
- Total number of data link words: 8,000 words
- Nodes that send messages: 2 nodes
- Bytes in all messages sent:  $2,012 \times 2 \text{ bytes}$

In this example, A to E in the equation have the following values.

- A: 8,000
- B: 4
- C: 8
- D: 2
- E: 4,024

The communications cycle time is thus as follows:

$$10 \times 8,000 + 600 \times 4 + 290 \times 8 + 320 \times 2 + 4 \times 4,024 + 3,290 = 104,746 \text{ (}\mu\text{s)}$$

$$\cong 105 \text{ (ms)}$$

### 9-2-2 Inactive Data Links

The following equations are used to calculate the communications cycle time when the data links are inactive. (The communications cycle time will vary somewhat depending on the baud rate and the conditions at that particular time.)

#### Wired Systems

Baud rate	Equation
2 Mbps	$600 \times B + 110 \times C + 320 \times D + 4 \times E + 2,290$ ( $\mu\text{s}$ )
1 Mbps	$1,150 \times B + 150 \times C + 360 \times D + 8 \times E + 2,690$ ( $\mu\text{s}$ )
500 Kbps	$2,260 \times B + 230 \times C + 440 \times D + 16 \times E + 3,490$ ( $\mu\text{s}$ )

#### Optical Systems

Baud rate	Equation
2 Mbps (fixed)	$1,300 \times B + 110 \times C + 320 \times D + 4 \times E + 2 \times F + 2,290$ ( $\mu\text{s}$ )

- Note** B: Number of polled nodes per comm cycle (value specified in the network parameter)  
 C: Number of nodes connected to network  
 D: Number of nodes that send messages during the communications cycle  
 E: Total number of bytes in messages transmitted during the communications cycle  
 F: Extra communications time for long distance Optical Fiber Cable connections.  $F = 7 \times L \mu\text{s}$  (L is the cable length in km.)

#### Calculation Example

Communications conditions are as follows:

- Transmission medium: Twisted-pair cables
- Baud rate: 2 Mbps
- Network parameters: Defaults
- Max node address: 32
- Polled nodes per comm cycle: 4
- Event-frames per comm cycle: 35
- Network configuration: 8 nodes
- Nodes that send messages: 2 nodes
- Bytes in all messages sent:  $2,012 \times 2$  bytes

In this example, B to E in the equation have the following values.

- B: 4
- C: 8
- D: 2
- E: 4,024

The communications cycle time is thus as follows:

$$600 \times 4 + 110 \times 8 + 320 \times 2 + 4 \times 4,024 + 2,290 = 22,306 \text{ } (\mu\text{s})$$

$$\cong 22 \text{ (ms)}$$

### 9-3 Data Link I/O Response Time

The data links of the Controller Link Support Board require a slight time delay from the time the data link area of one node is changed until this change is reflected in the data link area at another node. This time delay is called the data link I/O response time.

### 9-3-1 Computer to PC

In the following diagram illustrating the maximum data link I/O response time, a C200HX/HG/HE is used for the PC (#2) and the PC's cycle time is greater than or equal to the communications cycle time.

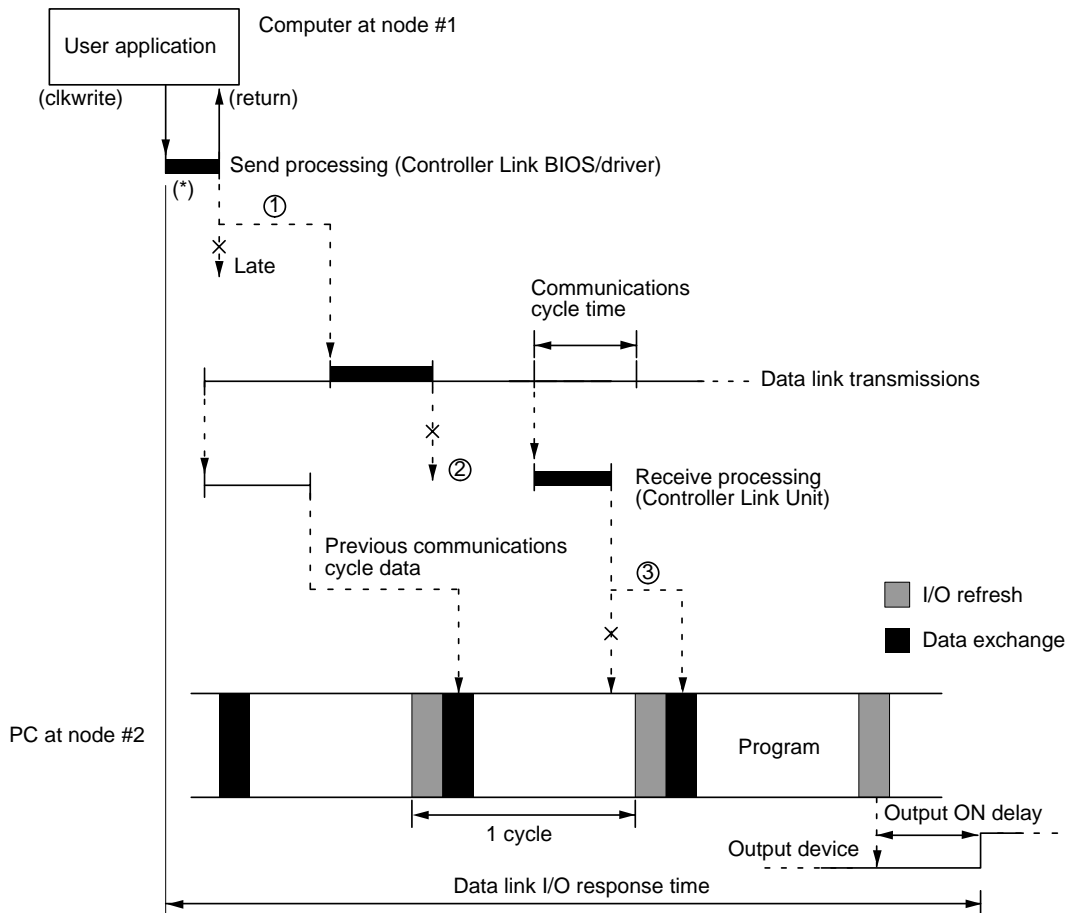

There are three points shown in the diagram above where processing is delayed, increasing the data link I/O response time.

- 1, 2, 3...**
1. Data exchange occurs just after the computer at node #1 passes the token that makes it the polling node, causing a delay of up to one communications cycle time before the data is transferred in data link processing.
  2. At node #2, data from the previous data exchange is still being transferred, causing a delay of up to one cycle before the input is read into the PC.
  3. The data transferred in data link processing arrives at the PC at node #2 after data exchange, so the data will not be read into the PC until the next data exchange, causing a delay of up to one cycle.

The maximum number of words that can be exchanged in a single data exchange is 2,000 for CV-series PCs, 4,000 for C200HX/HG/HE PCs, or 6,000 for CS1-series PCs.

- Note**
1. Noise may increase I/O delays.
  2. The data send processing time for the area marked by the asterisk (\*) in the diagram will be affected by the processing capacity of the computer that is used.
  3. The communications cycle time may fluctuate.
  4. For details regarding the time required for data exchanges between the Controller Link Unit and the PC, refer to the *Controller Link Units Operation Manual (W309)*.



### 9-3-2 PC to Computer

In the following diagram illustrating the maximum data link I/O response time, a C200HX/HG/HE is used for the PC (#2) and the PC's cycle time is greater than or equal to the communications cycle time.

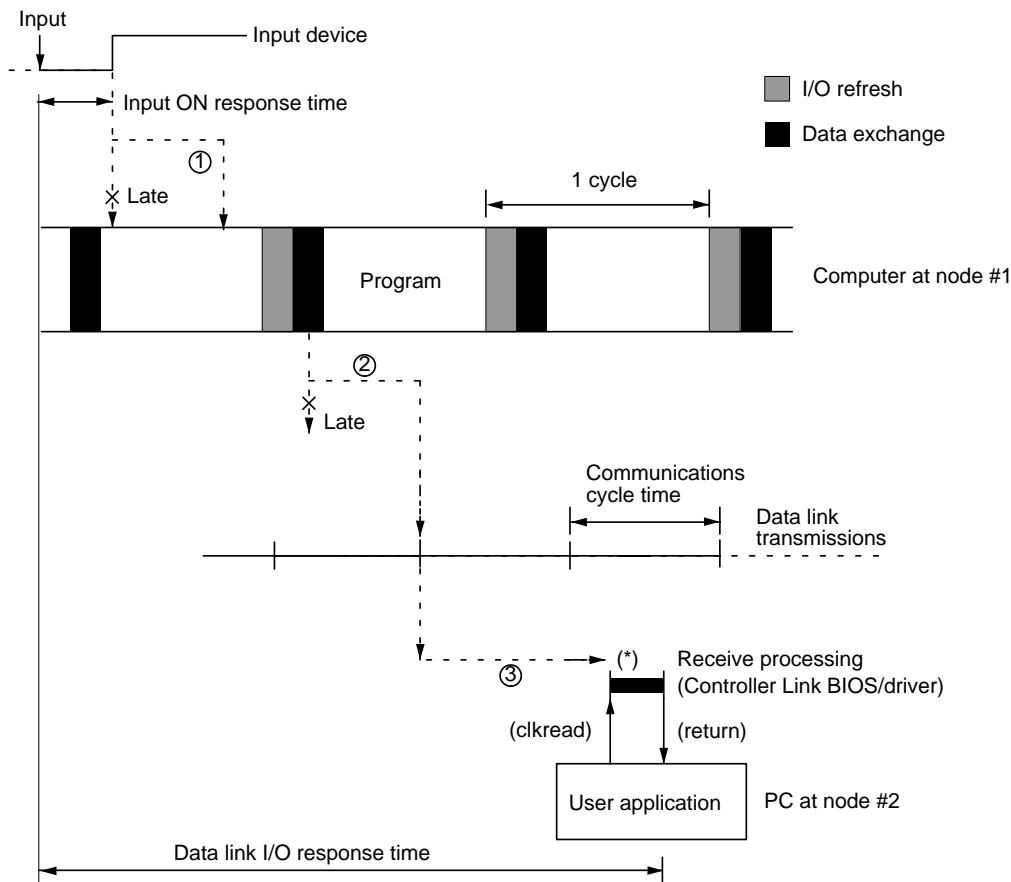

There are three points shown in the diagram above where processing is delayed, increasing the data link I/O response time.

- 1, 2, 3...**
1. The input arrives in the PC just after I/O refreshing, causing a delay of up to one cycle before the input is read into the PC.
  2. Data exchange occurs just after the PC at node #2 passes the token that makes it the polling node, causing a delay of up to one communications cycle time before the data is transferred in data link processing.
  3. The data arrives at the Data Link Area of the Support Board mounted at the computer at node #1, but processing is delayed until the user application executes the DATA AREA READ library function or driver call. This delay will vary depending on the contents of the user application.

- Note**
1. Noise may increase I/O delays.
  2. The data send processing time for the area marked by the asterisk (\*) in the diagram will be affected by the processing capacity of the computer that is used.
  3. The communications cycle time may fluctuate.
  4. Refer to the *Controller Link Units Operation Manual (W309)* for details on the time required for data exchanges between the Controller Link Unit and the PC.

## 9-4 Message Service Delay Times

The following diagram illustrates the maximum message service transmission delay time. In this example, the MEMORY AREA READ FINS command is sent to the PC at node #2 by the user application at the computer at node #1.

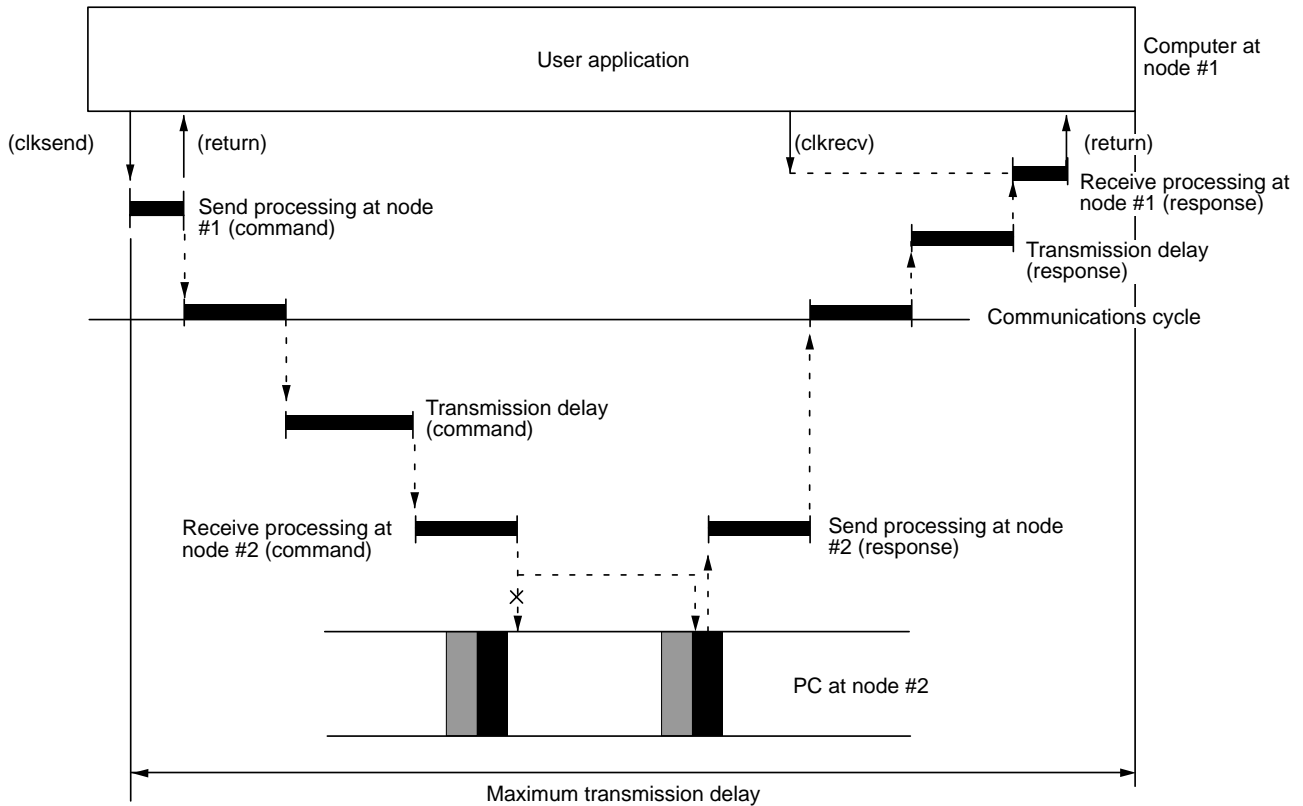

Maximum transmission delay time = Send processing (node #1) + Communications cycle time + Transmission delay time (for command) + Receive processing (node #2) + PC processing time (node #2) + Send processing (node #2) + Communications cycle time + Transmission delay time (for response) + Receive processing (node #1)

### **Send/Receive Processing at Node #1**

Depends on the processing capacity of the computer that is used.

### **Communications Cycle Time**

See 9-2 *Communications Cycle Time* (on page 159).

### **Transmission Delay Time**

Transmission delay time varies with the baud rate.

Baud rate	Transmission delay time
2 Mbps	Number of words transferred × 0.008 + 0.112 ms
1 Mbps	Number of words transferred × 0.016 + 0.224 ms
500 Kbps	Number of words transferred × 0.032 + 0.448 ms

### **Receive Processing at Node #2**

Number of words transferred × 0.00125 + 2.3 ms

### **Send Processing at Node #2**

Number of words transferred × 0.00125 + 3.0 ms

- Note**
1. The I/O response time can increase due to noise or restrictions on the number of frames that can be transmitted while data links are operating.
  2. Refer to the *Controller Link Units Operation Manual (W309)* for details on the time from reception at the Controller Link Unit until transmission.

# SECTION 10

## Troubleshooting and Maintenance

This section provides information on troubleshooting errors that occur during Controller Link Support Board operation, as well as daily inspection, cleaning, and other maintenance procedures.

10-1	Troubleshooting Using Indicators .....
10-1-1	Using the RUN, ERC, ERH and INS Indicators (Wired Boards) .....
10-1-2	Using the RUN, ERR and INS Indicators (Optical Boards) .....
10-1-3	Troubleshooting with LNK Indicators .....
10-2	Status Information and Troubleshooting .....
10-2-1	Checking Errors Using the STATUS READ Command .....
10-2-2	Error Processing .....
10-3	Error Log .....
10-3-1	Error Log Table .....
10-3-2	Error Codes .....
10-3-3	Reading and Clearing Error Logs .....
10-4	Cleaning and Inspection .....
10-4-1	Cleaning .....
10-4-2	Inspection .....
10-5	Handling Precautions .....
10-5-1	Replacing the Unit .....
10-5-2	Replacing the Board .....

## 10-1 Troubleshooting Using Indicators

This section describes the errors shown by the Controller Link Support Board indicators and possible remedies.

Wired Board



RUN: Operating  
 ERC: Communications error  
 ERH: EEPROM error  
 INS: Network participation  
 LNK: Data link

Optical Board

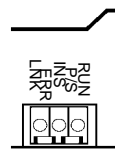

RUN: Operating  
 ERR: Error  
 INS: Network participation  
 LNK: Data link

### 10-1-1 Using the RUN, ERC, ERH and INS Indicators (Wired Boards)

The Wired Board's RUN, ERC, ERH, and INS indicators can be used to check whether Controller Link Support Board startup and Network participation are operating normally.

**Note** Be sure to turn OFF the power to the PC before performing any of the following.

- Disconnecting the Board or connectors.
- Securing Board or connectors.
- Setting hardware switches.

Indicators				Probable cause	Probable remedy
RUN	ERC	ERH	INS		
Lit	Not lit	Not lit	Lit	Unit operating normally; Network participation normal.	---
Not lit	Lit	---	---	The Controller Link Support Board is faulty.	If the ERC indicator still lights when the Board is mounted on another computer, replace the Controller Link Support Board.
Not lit	Not lit	Not lit	Not lit	Power is not being supplied correctly to the computer.	Check the power supply voltage and supply at the recommended voltage.
				The Controller Link Support Board has become loose.	Secure the Controller Link Support Board firmly.
				The Controller Link Support Board is mounted in the wrong slot.	Refer to <i>Section 2 Setting, Installing, and Wiring Boards</i> and mount the Board correctly.
				The Controller Link Support Board is faulty.	If the indicators do not light when the Board is mounted in another computer, replace the Controller Link Support Board.
Lit	Lit	---	Not lit	The same node address is being used by two different Units.	Reset so that each node address is used only once within the same Network.
Lit	---	Lit	---	Routing table setting error.	Reset the routing table correctly, referring to <i>8-3 Setting Routing Tables</i> . When no routing table is being used, delete the routing table.
				EEPROM error	Refer to <i>10-2 Status Information and Troubleshooting</i> , correct the data where the error has occurred, and reset the Board. If the error occurs again, replace the Controller Link Support Board.

Indicators				Probable cause	Probable remedy
RUN	ERC	ERH	INS		
Lit	---	---	Not lit	Terminating resistance is not set correctly.	Turn ON the terminating resistance at the nodes at both ends of the Network and turn it OFF at all other nodes.
				Cables are not connected correctly.	Check the cable connections and reconnect correctly.
				The node address is larger than the maximum node address set for the network parameters.	Either reset the maximum node address using the Controller Link Support Software or reset the node address to below the maximum.
				No other nodes exist.	Make sure that 2 or more nodes exist within the Network.
				No node has been set as a polling node.	Refer to 3-2 <i>Installation Method</i> and set at least one polling node. (A Controller Link Support Board should normally be set as the polling node.)
				The set baud rate is different to other nodes.	Refer to 3-2 <i>Installation Method</i> and reset the baud rate.

### 10-1-2 Using the RUN, ERR and INS Indicators (Optical Boards)

The Optical Board's RUN, ERR, and INS indicators can be used to check whether Controller Link Support Board startup and Network participation are operating normally.

**Note** Be sure to turn OFF the power to the PC before performing any of the following.

- Disconnecting the Board or connectors.
- Securing Board or connectors.
- Setting hardware switches.

Indicators			Probable cause	Probable remedy
RUN	ERR	INS		
Lit	Not lit	Lit	Unit operating normally; Network participation normal.	---
Not lit	Lit	---	The Controller Link Support Board is faulty.	If the ERR indicator still lights when the Board is mounted on another computer, replace the Controller Link Support Board.
Not lit	Not lit	Not lit	Power is not being supplied correctly to the computer.	Check the power supply voltage and supply at the recommended voltage.
			The Controller Link Support Board has become loose.	Secure the Controller Link Support Board firmly.
			The Controller Link Support Board is mounted in the wrong slot.	Refer to <i>Section 2 Setting, Installing, and Wiring Boards</i> and mount the Board correctly.
			The Controller Link Support Board is faulty.	If the indicators do not light when the Board is mounted in another computer, replace the Controller Link Support Board.
Lit	Lit	Not lit	The same node address is being used by two different Units.	Reset so that each node address is used only once within the same Network.
			Connected to a SYSMAC LINK Network	Check the Network and reconnect the cables correctly.
Lit	Lit	---	Routing table setting error.	Reset the routing table correctly, referring to 8-3 <i>Setting Routing Tables</i> . When no routing table is being used, delete the routing table.
			EEPROM error	Refer to 10-2 <i>Status Information and Troubleshooting</i> , correct the data where the error has occurred, and reset the Board. If the error occurs again, replace the Controller Link Support Board.

Indicators			Probable cause	Probable remedy
RUN	ERR	INS		
Lit	---	Not lit	Cables are not connected correctly.	Check the cable connections and reconnect correctly.
			The node address is larger than the maximum node address set for the network parameters.	Either reset the maximum node address using the Controller Link Support Software or reset the node address to below the maximum.
			No other nodes exist.	Make sure that 2 or more nodes exist within the Network.
			No node has been set as a polling node.	Refer to 3-2 <i>Installation Method</i> and set at least one polling node. (A Controller Link Support Board should normally be set as the polling node.)

### 10-1-3 Troubleshooting with LNK Indicators

#### Data Link Cannot be Started

The following table describes the LNK indicators at the startup node and their use in troubleshooting when a data link cannot be started.

Starting a data link depends on the Controller Link Support Board operating normally and participating in the Network. Refer to 10-1-1 *Using the RUN, ERC, ERH and INS Indicators (Wired Boards)* or 10-1-2 *Using the RUN, ERR, and INS Indicators (Optical Boards)* earlier in this section and check Board operation before using the following table.

Indicators	Probable cause	Probable remedy
LNK		
Lit	Data link operating normally.	---
Flashing	There is an error in the data link tables.	When the ERH indicator is flashing, reset the data link tables.
	When manual setting is used, either data link tables have not been created for the startup node or there is an error in the data link tables.	Refer to 6-2-2 <i>Manual Setting</i> and set data link tables for the startup node.
Not lit	Manually set data links are already operating on the same Network.	Refer to 10-5 <i>Handling Precautions</i> .
	Automatically set data links are already operating on the same Network.	Refer to 10-5 <i>Handling Precautions</i> .

#### Node Cannot Participate in Data Link

The following table describes the LNK indicators when a node cannot participate in the data links.

Data link participation depends on the Controller Link Support Board operating normally and participating in the Network. Refer to 10-1-1 *Using the RUN, ERC, ERH and INS Indicators (Wired Boards)* or 10-1-2 *Using the RUN, ERR, and INS Indicators (Optical Boards)* earlier in this section and check Unit operation before using the following table.

Indicators	Probable cause	Probable remedy
LNK		
Lit	Data link operating normally.	---
Flashing	When manual setting was used, there is an error in the data link table.	Refer to <i>6-2-2 Manual Setting</i> and reset the data link table.
Not lit	For manual setting, there are no data link tables set for the local node.	Set data link tables for the local node.
	For automatic setting, the startup node is not set to participate in the data links.	Stop the data links, reset the parameters in the startup node's DM Area, and then restart the data link.  The Controller Link Support Board cannot become the start-up node for automatic setting, so set on the PC to which the Controller Link Unit is mounted. For details refer to the <i>Controller Link Units Operation Manual (W309)</i> .

**Data Links Cannot be Stopped**

The following explanation describes how to use the LNK indicator when the data links cannot be stopped. Stopping the data links depends on the Controller Link Support Board operating normally and participating in the Network. Read the above explanations before attempting to stop operation.

**Note** Stop the data link from the node at which the LNK indicator is flashing (indicating active data links). Data links cannot be stopped from nodes which do not have active data links.

Indicators	Probable cause	Probable remedy
LNK		
Not lit	Data link stopped normally.	---

# 10-2 Status Information and Troubleshooting

The Controller Link Support Board contains status information which reflects the current status of communications and the Board. This status information can be read using the STATUS READ or DATA LINK AREA READ FINS command. The cause of the error can be found by reading the status information.

This section explains the contents of the Status Area and tells how to troubleshoot errors recorded there.

## 10-2-1 Checking Errors Using the STATUS READ Command

The following errors can be read using the STATUS READ command.

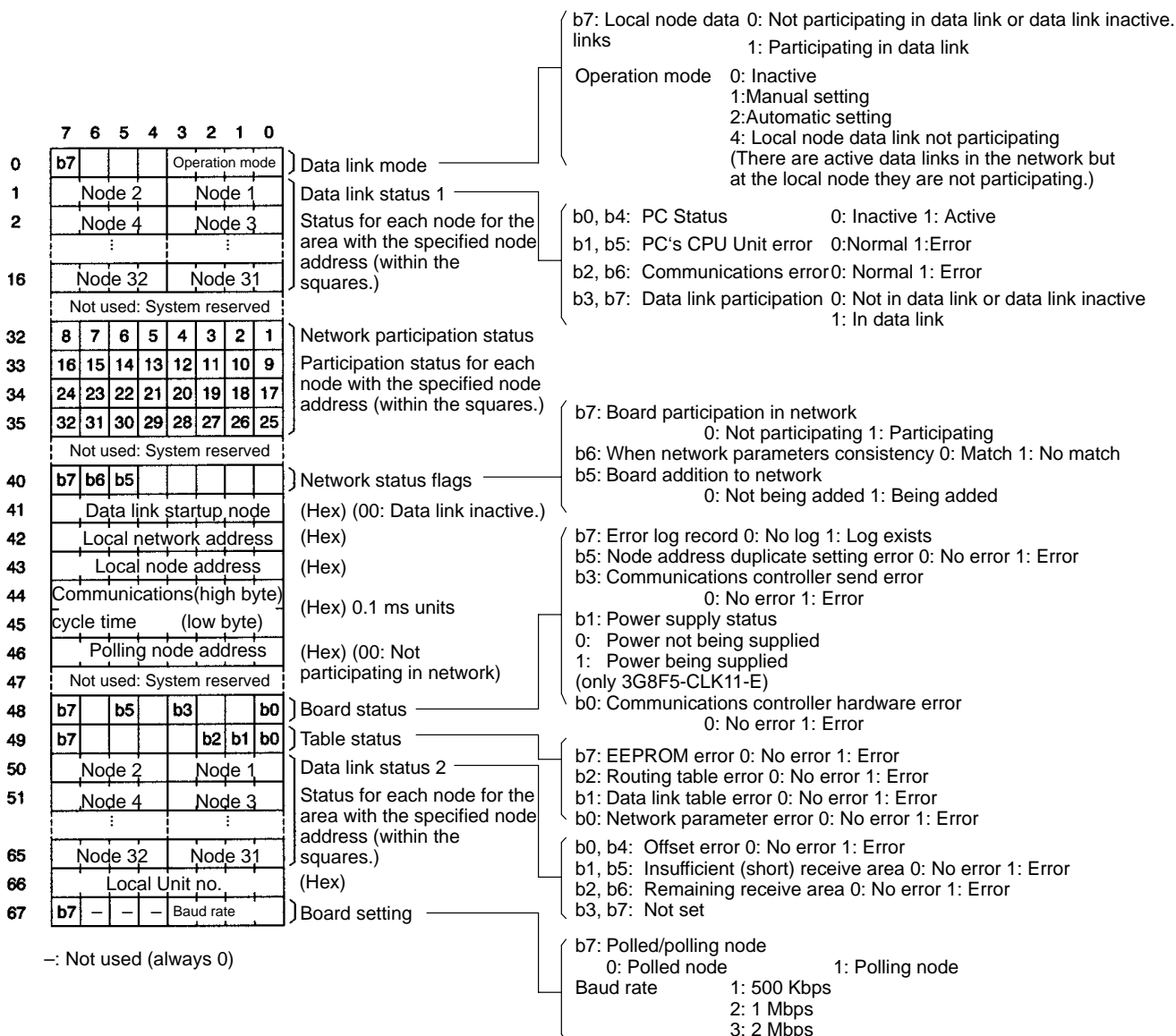



## 10-2-2 Error Processing

### Data Link Status

Bit status	Probable cause	Probable remedy
PC's CPU Unit error is 1: ON	A fatal PC error, non-fatal PC error, or a watchdog timer error has occurred.	Refer to the PC's operation manual and correct the error. If the error occurs again, replace the PC.
	The Unit is mounted to a non-compatible PC.	Mount onto the correct PC.
Communications error is 1: ON	The relevant node is not in the Network.	Enter the node in the Network.
	A communications error has occurred as a result of noise.	Conduct an echoback test using the Controller Link Support Software and if this does not correct the error, check the usage environment.
	A communications error has occurred.	Refer to <i>10-1-1 Using the RUN, ERC, ERH and INS Indicators (Wired Boards)</i> or <i>10-1-2 Using the RUN, ERR, and INS Indicators (Optical Boards)</i> and troubleshoot accordingly.
Data link participation is 0: OFF	The relevant node is not part of data links.	Enter the relevant node in data links. If an error occurs, refer to page 168, <i>Node Cannot Participate in Data Link</i> and troubleshoot accordingly.
	There are no active data links in the Network.	Activate the data links.
Offset error is 1: ON	The offset is greater than the number of send words at the relevant node.	Check the number of send words at the relevant node, the number of receive words at the local node and the offset, then reset the data link table correctly.
Receive area short is 1: ON	The send area at the relevant node is larger than the receive area and some data cannot be received.	When the intention is not to receive all data, use as is (data that cannot be received will be read and discarded.)  When it differs from the intended data link, check the number of send words at the relevant node, the number of receive words at the local node and the offset, then reset the data link table correctly.
Receive area remaining is 1: ON	The send area at the relevant node is smaller than the receive area and some of the area will be unused.	When the intention is to leave some space in the receive area, use as is (the surplus receive area will be unspecified data.)  When it differs from the intended data link, check the number of send words at the relevant node, the number of receive words at the local node and the offset, then reset the data link table correctly.

Other Status

Bit status	Probable cause	Probable remedy
Inconsistent network parameters is 1: ON	Indicates that the network parameters recorded in the CPU Unit's EEPROM differ from the values of the Network in use.	Check the network parameters on the Network in use using the Controller Link Support Software, and reset necessary parameters.
Error log exists is 1: ON	Error information on the Controller Link Support Board (an error log) has been recorded.	Using the Controller Link Support Software or an FINS command, read the cause of the current error. Alternatively, use past error log records to troubleshoot the problem.
Node address duplicate setting error is 1: ON	The same node address has been used more than once.	Reset so that each node address is used only once within the same Network.
Communications controller send error is 1: ON	The Controller Link Support Board is faulty.	Replace the Controller Link Support Board.
Communications controller hardware error is 1: ON	The Controller Link Support Board is faulty.	Replace the Controller Link Support Board.
EEPROM error is 1: ON	An error has occurred while writing data to the CPU Unit's EEPROM.	Check the status of bits 00 to 02 in (CIO 1500 + 25 × n, and correct any problems found. If the error occurs again, replace the CPU Unit.
Routing table error is 1: ON	The routing table data within the CPU Unit's EEPROM is damaged.	Refer to 8-3 <i>Setting Routing Tables</i> and reset the routing tables correctly. If the error occurs again, replace the Controller Link Support Board.
	There is an error in the routing table setting.	When using a routing table, refer to 8-3 <i>Setting Routing Tables</i> and reset the routing tables correctly. If no routing tables are being used, delete the tables.
Data link table error is 1: ON	The data link table data in the EEPROM of the CPU Unit is damaged.	Refer to 6-3 <i>Starting and Stopping Data Links</i> and reset the data link tables correctly. If the error occurs again, replace the CPU Unit.
	There is an error in the data link table settings.	When using manually set data links, refer to 6-3 <i>Starting and Stopping Data Links</i> and reset the data link tables correctly. When manually set data links are not being used, delete the data link tables.
Network parameter area is 1: ON	The CPU Unit's EEPROM data link tables or the network parameters are damaged.	Refer to 9-1-3 <i>Network Parameters</i> and reset the data correctly. If the error occurs again, replace the CPU Unit.
		Either set the EEPROM Clear Bit in the DM parameter area to ON, or use the Initialize network parameters operation on the Maintenance Menu of the Controller Link Support Software to initialize the network parameters and then cycle the power supply.
	There is an error in the network parameter settings, or node address of the local node is larger than the maximum address set within the network parameters.	Refer to 9-1-3 <i>Network Parameters</i> and reset the network parameters or the node address.

## 10-3 Error Log

The error log records errors that occur in the Controller Link Support Board and the time they occur. The error log can be read or cleared using the Controller Link Support Software, a PC Programming Device, such as the SYSMAC Support Software, or the message service (FINS commands for the Controller Link Support Board.)

### 10-3-1 Error Log Table

Errors are recorded in an error log table in the Board's RAM, with one record for each error and a maximum of 39 records.

Serious errors are also recorded in the Board's EEPROM so that when the power to the Board is turned OFF or reset, a record of the error will remain. (The error log table in EEPROM automatically reads the Board's RAM when the power is turned ON again.)

Item	Specification
No. of records	39 max.
Data code	Binary (Times are in BCD)
Length of each record	10 bytes
Configuration of records	Error code: 2 bytes (Refer to 10-3-2 Error Codes) Detail code: 2 bytes (Refer to 10-3-2 Error Codes) Time: 6 bytes (Refer to the Time Information)
Record order	From the oldest record to the most recent.

If the number of records exceeds 39, the oldest record will be deleted and the most recent error recorded.

### Error Log Table Configuration

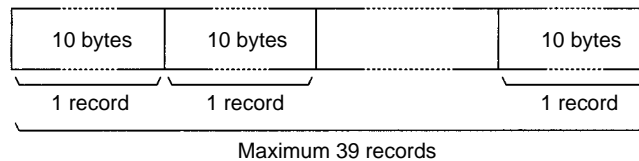

#### Record Configuration

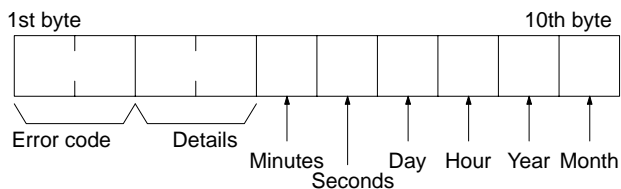

### Time Information

The time is recorded in BCD with one byte each for the year (the rightmost two digits), month, day, hour, seconds, and minutes of the time the error occurred.

**Note** The computer's time information can be read and used in the Controller Link Support Board. When the time cannot be read from the computer, all error log times will be 0. When error logs are read from the Controller Link Support Software, they will be dated 0 s, 0 min, 0 hr, 0 day, 0 month, 2000.

### 10-3-2 Error Codes

The following table lists the error codes (in 4-digit hexadecimal) and the contents of the errors.

Error code	Contents	Detail code		Correction	Recorded in EEPROM
		1st byte	2nd byte		
0101 Hex	Transmission failed; local node not in Network	<b>Command block</b> Bits 0 to 7: Source node address Bits 8 to 14: Source Network address Bit 15: OFF <b>Response block</b> Bits 0 to 7: Destination node address Bits 8 to 14: Destination Network address Bit 15: ON (1st byte: bits 8 to 15; 2nd byte, bits 0 to 7)		Refer to <i>10-1 Troubleshooting Using Indicators</i> and place the local node into Network.	No
0103 Hex	Transmission failed; retry count exceeded			Using the Controller Link Support Software or FINS commands, run echoback test and check operating environment if errors occur.	No
0104 Hex	Transmission failed; maximum number of frames exceeded.			Reduce the number of events per communications cycle or increase the maximum number of network parameter frames.	No
0105 Hex	Transmission failed; node address incorrect			Refer to <i>Section 3 Software Installation</i> and check node address settings to be sure they are within range and unique.	No
0106 Hex	Transmission failed; redundant node address			Correct node addresses so that they are unique within the same Network.	No
0107 Hex	Transmission failed; destination node not in Network			Refer to <i>10-1 Troubleshooting Using Indicators</i> and place destination node into Network.	No
0109 Hex	Transmission failed; destination busy			Increase number of retries or reconfigure system to distribute load.	No
010A Hex	Transmission failed; communications controller error			Conduct an echoback test and if the effects of noise are considerable, reconsider the operating environment. Restart the Controller Link Support Board. If the error occurs again, replace the Board.	Yes
010D Hex	Transmission failed; destination address incorrect			Check routing tables.	No
010E Hex	Transmission failed; routing tables not registered				No
010F Hex	Transmission failed; routing table error	No			
0110 Hex	Transmission failed; too many relay points	Check routing tables and system configuration. Do not try to access Networks separated by more than one other Network.	No		
0111 Hex	Transmission failed; command packet too long	Be sure to use the correct FINS command format.	No		
0112 Hex	Transmission failed; header error.		No		
0117 Hex	Internal buffer full	Increase number of retries or reconfigure system to distribute load.	No		
0118 Hex	Illegal packet discarded	Check for nodes sending illegal packets.	Yes		

Error code	Contents	Detail code		Correction	Recorded in EEPROM
		1st byte	2nd byte		
0203 Hex	EEPROM error	01 Hex: Read error 02: Hex: Write error	01 Hex: Data link tables 02 Hex: Network parameters 03 Hex: Routing tables	Reset the relevant data. If the error occurs again replace the Controller Link Support Board.	Yes
0206 Hex	Number of participating nodes decreased (local node still participating)	Network parameters maximum node address	Number of non-participating nodes	Check network parameters, node participation, cables, and terminating resistance.	No
0207 Hex	Number of participating nodes decreased (local node not participating)				No
0208 Hex	polling node changed	Address of previous polling node	Address of new polling node	Check previous polling node.	No
0209 Hex	Network parameter disagreement	00 Hex	Address of polling node	Using the Controller Link Support Software, check network parameters.	Yes
020C Hex	Time out with token	00 Hex	Error status (see note 2)	Check network parameters, node participation, cables, and terminating resistance.	No
0210 Hex	Communications controller transmitter error	00 Hex		Replace the Controller Link Support Board.	Yes
0211 Hex	Duplicate node address error	00 Hex	Local node address	Reset so that each node address is used only once within the same Network.	No
0216 Hex	Power supply error	00 Hex	01 Hex: OFF→ON 02 Hex: ON→OFF	The power supply went from OFF to ON or vice-versa. Check the power supply's operating conditions.	Yes
021A Hex	Set table logic error	00 Hex	01 Hex: Network parameters 02 Hex: Data link tables 03 Hex: Routing tables	Reset the appropriate data.	Yes
021B Hex	Hardware error	00 Hex	Error status (see note 2)	Replace the Controller Link Support Software.	No
021C Hex	Data link error stopped	Not set		Stop the user application, reset the computer and retry.	Yes
0300 Hex	Packet discarded	Not set		Conduct an echoback test and find the cause of the error.	No
0601 Hex	Board error	Not set		Check the operating environment.	Yes

**Note** 1. Errors indicated by error codes 0101 to 0116 are recorded only when the frame was discarded because transmission was impossible.

**2. Error Status**

The status of each bit indicates that an error has occurred as given in the diagram below.

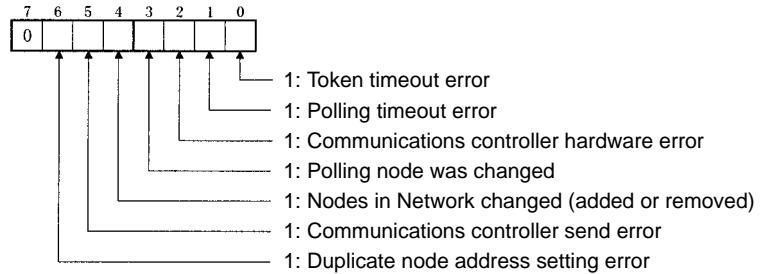

**10-3-3 Reading and Clearing Error Logs**

Error logs can be read or cleared using the Controller Link Support Software, CX-Programmer, PC Programming Devices, or the message service. The following examples are for the Controller Link Support Software and the message service. When using other Programming Devices, refer to the Programming Device’s operation manual for details.

**Controller Link Support Software**

Read or clear the error log using the following procedure.

- 1, 2, 3...**
1. Display the Main Menu.
  2. Select “E: Error log.”
  3. Designated the node. The error log for the designated node will be displayed.
  4. Press the F7 (Clear) Key. The designated node error log will be cleared.

**Message Service**

**Reading an Error Log**

Send the ERROR LOG READ FINS command (command code 2102) to the appropriate node. Refer to 7-3-11 ERROR LOG READ.

**Clearing an Error Log**

Send the ERROR LOG CLEAR FINS command (command code 2103) to the appropriate node. Refer to 7-3-12 ERROR LOG CLEAR.

**10-4 Cleaning and Inspection**

This section describes cleaning and inspection procedures that are to be performed as daily maintenance.

**10-4-1 Cleaning**

Conduct the following periodic cleaning to keep the Controller Link Support Board in optimum condition.

- Wipe the Unit with a dry, soft cloth daily.
- For stains that cannot be removed with a dry cloth, dip the cloth in medium strength alcohol (2%), wring the cloth tightly, and then wipe down the Board.
- If glue, vinyl, or tape is left on the Board for long periods of time, it will stain. Remove these items during cleaning.



**Caution**

Do not use volatile solvents such as benzine or paint thinner, or chemical cloths for cleaning. They will damage the quality of the coating on the Board.

## 10-4-2 Inspection

Controller Link Support Boards must be inspected on a regular basis to ensure correct operation. Inspections should be conducted once every 6 to 12 months. If the Board is subject to extremes in temperature or humidity, inspections should be conducted on a more regular basis.

### Tools and Equipment Need for Inspection

The following tools and equipment will be needed to perform inspection and adjustments.

- Assorted flat-blade and Phillips screwdrivers
- Circuit tester or digital voltmeter
- Industrial-grade alcohol and clean cotton cloth
- Synchroscope
- Pen-chart recording oscilloscope
- Thermometer, hygrometer

### Inspection Items

Inspect the following items to see if they deviate from the prescribed standards. If any items do deviate from the standard either adjust so they are within the operating range or adjust the Board accordingly.

Item	Description	Inspection instrument
Ambient conditions	Temperature: 5° to 45°C	Thermometer
	Humidity: 8% to 80% (no condensation or freezing)	Hygrometer
	Dust-free	Sight
Installation	Units securely attached? Communications cable connectors tight? Screws tightened on terminal blocks for external wiring? Communications cabling used for external wiring intact (no breaks)?	Flat-blade screw driver and sight

## 10-5 Handling Precautions

The Controller Link Support Board is a Network device. If the Board is damaged, it will effect the entire Network, so always ensure repairs are undertaken immediately. We recommend that you have a spare Controller Link Support Board on hand so that repairs may be conducted quickly.

### 10-5-1 Replacing the Unit

Observe the following precautions when replacing the Board.

- Always turn off the power before replacing the Board.
- Check that the new Board is not faulty.
- If you suspect that a poor connection is the cause of a malfunction, clean the connector terminals using a clean, soft cloth and industrial-grade alcohol. Remove any lint or threads left from the cloth, and remount the Board.
- When returning a faulty Board for repairs, always attach a detailed fault report to the Unit and return to you nearest OMRON outlet as listed at the back of this manual.

**Note** In order to prevent faulty operation be sure to turn off the power to all nodes before replacing the Board.

## 10-5-2 Replacing the Board

- Note**
1. When replacing the Board, do not reconnect that node to the Network before carrying out the procedures listed below. In particular, a node with a small address will become the polling node and communicate the initial network parameter status to other nodes, so there is the chance that network parameters in the entire Network will be damaged.
  2. The data link table, network parameters, and routing table are stored in the Controller Link Support Board's EEPROM. When the Board has been replaced, make these settings again before starting operation.

### Replacement Method 1

Saving the data set in the Board's EEPROM to file before replacing the Board so that the data can be used after replacement.

- 1, 2, 3...**
1. From the Maintenance Menu on the Controller Link Support Software, select "Unit Back-up" and then "Board → Computer." The data will be saved as a file in the Board's EEPROM.
 

**Note**

    - a) Data link tables, network parameters and routing tables are saved in this way.
    - b) Depending on the extent of the damage to the Board, the Controller Link Support Software may not be able to be used. If an error message appears when the Support Software is used, use replacement method 2.
  2. Turn off all nodes in the Controller Link Network.
  3. Detach the communications cables attached to the Controller Link Support Board to be replaced and remove the Board.
  4. Set the new Controller Link Support Board's memory allocation switch, allocation setting circuit pin, and the terminating resistance switch to the same as for the previous Board.
  5. Mount the Controller Link Support Board in the expansion slot of the computer and connect the communications cables.
  6. Turn ON the power only to the computer for which the Support Board was replaced and start-up the Support Software. Only the RUN indicator on the Board's display panel should light.
  7. From the Maintenance Menu on the Controller Link Support Software, select "Board → Computer" and load the data saved in step one to the Board's EEPROM.
  8. Exit the Controller Link Support Software and turn OFF the power to the computer.
  9. Turn ON the power to all nodes on the network and start-up the Controller Link Support Software at the node at which the Board was replaced.
  10. Using the Controller Link Support Software, read the network parameters and make sure the Network is operating normally.
  11. If the data links are not activated automatically, activate the data links from the data link startup node.
  12. Check that the data links are operating normally by using the "Data Link Status Monitor" on the Controller Link Support Software.

### Replacement Method 2

This method sets the network parameters saved in EEPROM automatically from other nodes on the network. Data link tables must be reset using the Controller Link Support Software.

- 1, 2, 3...**
1. Rewrite the computer's CONFIG.SYS so the Controller Link BIOS is activated as a polled node (add the /K option to the Controller Link BIOS driver column.)
  2. Turn the power OFF to the computer at which the replacement was made.



3. Detach the communications cables attached to the Controller Link Support Board to be replaced and remove the Board.
4. Set the new Controller Link Support Board's memory allocation switch, allocation setting circuit pin, and the terminating resistance switch to the same as for the previous Board.
5. Mount the Controller Link Support Board in the expansion slot of the computer and connect the communications cables.
6. Turn ON the power to only the computer for which the Support Board was replaced and startup the Support Software. Only the RUN indicator on the Board's display panel should light.
7. Using the "data link" function of the Controller Link Support Software set the data link tables for the new Controller Link Support Board.
8. Exit the Controller Link Support Software and turn OFF the power to the computer.
9. Turn ON the power to all nodes on the network and start up the Controller Link Support Software at the node at which the Board was replaced. The RUN and INS indicators on the new Board should be lit (in some cases SD, RD and LNK indicators will also be lit.)
10. Using the Controller Link Support Software, read the network parameters and make sure the Network is operating normally.
11. Exit the Controller Link Support Software and return the CONFIG.SYS file altered in step one to normal (delete the /K option from the Controller Link BIOS driver column and set for activation as a polling node.)
12. Turn the power to the computer ON again and start up the Controller Link Support Software at the node at which the Board was replaced. The RUN and INS indicators on the new Board should be lit (in some cases SD, RD and LNK indicators will also be lit.)
13. If the data links are not activated automatically, activate the data links from the data link startup node.
14. Check that the data links are operating normally by using the "Data Link Status Monitor" on the Controller Link Support Software.

# Appendix

## Standard Models

### Controller Link Support Boards

Applicable computer	Connection type	Model number	Remarks
IBM PC/AT or compatible	Wired	3G8F5-CLK21-E	Controller Link Support Software included.
	Optical	3G8F5-CLK11-E	

### Controller Link Units

Applicable PC	Connection type	Model number	Remarks
CV-series PCs	Wired	CVM1-CLK21	See <i>CPU Units and Peripheral Devices</i> in this appendix.
C200HX/HG/HE PCs	Wired	C200HW-CLK21	
CS1-series PCs	Wired	CS1W-CLK21	
	Optical	CS1W-CLK11	

### Controller Link Support Software

Applicable computer	Model number	Remarks
IBM PC/AT or compatible	C200HW-ZW3AT2-E	English version

### Communications Cables (for Wired Systems)

Model	Manufacturer	Remarks
Li2Y-FCY2 x 0.56 qmm	Kromberg & Schubert, Komtec Department	German company
1 x 2 x AWG-20PE + Tr.CUSN + PVC	Draka Cables Industrial	Spanish company
#9207	Belden	USA company
ESVC 0.5 x 2 C	Bando Densen Co.	Japanese company

### Optical Fiber Cable Connectors and Accessories

Name	Model	Remarks
Optical Connector	S3200-COCF2011	Connects a cable to a node. Two connectors are required for each cable. (Full-lock connector for crimp-cut cable.)
	S3200-COCF2511	Connects a cable to a node. Two connectors are required for each cable. (Half-lock connector for crimp-cut cable.)
	S3200-COIAT2000	Connects two cables. One adapter is required to connect two cables.
Optical Fiber Assembly Tool	S3200-CAK1062	For the S3200-COCF2011/2511 Connectors
Optical Power Tester	S3200-CAT2700	S3200-CAT2702 Head Unit, For the S3200-COCF2011/2511 Connectors
Master Fiber Set	S3200-CAT2001H	For the S3200-COCF2011/2511 Connectors

# Optical Fiber Cables

Name	Specifications		Model
H-PCF cables	Black	10 m	S3200-HCCB101
		50 m	S3200-HCCB501
		100 m	S3200-HCCB102
		500 m	S3200-HCCB502
		1,000 m	S3200-HCCB103
	Orange	10 m	S3200-HCCO101
		50 m	S3200-HCCO501
		100 m	S3200-HCCO102
		500 m	S3200-HCCO502
		1,000 m	S3200-HCCO103

**Note** The Optical Fiber Cable model numbers are as follows.

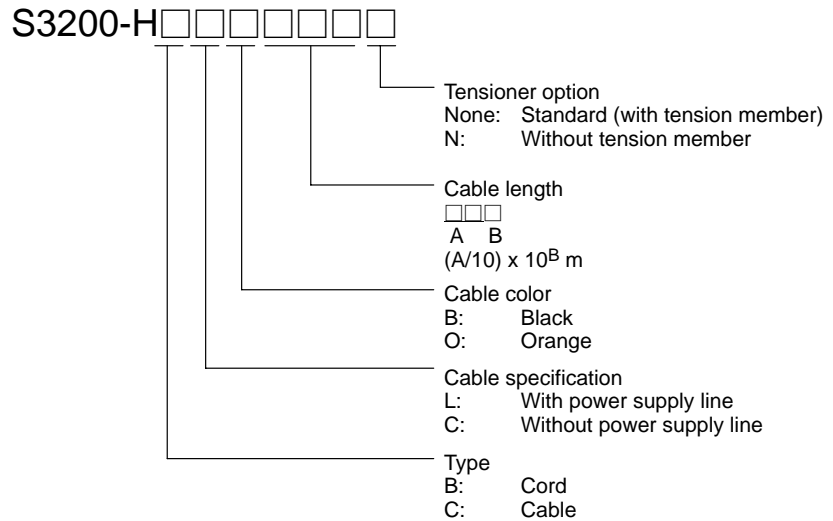

## Optical Fiber Cable with Connectors

The following Optical Fiber Cables are available with Connectors already attached. (These cables have power supply lines and tension members, which aren't used in the Controller Link Network.)

Specifications	Length	Model
Optical Fiber Cable Connectors: S3200-COCF2011 ↓ S3200-COCF2011	2 m	S3200-CN201-20-20
	5 m	S3200-CN501-20-20
	10 m	S3200-CN102-20-20
	15 m	S3200-CN152-20-20
	20 m	S3200-CN202-20-20
	Over 20 m	S3200-CN-20-20 (Specify length (m) when ordering.)
Optical Fiber Cable Connectors: S3200-COCF2011 ↓ S3200-COCF2511	2 m	S3200-CN201-20-25
	5 m	S3200-CN501-20-25
	10 m	S3200-CN102-20-25
	15 m	S3200-CN152-20-25
	20 m	S3200-CN202-20-25
	Over 20 m	S3200-CN-20-25 (Specify length (m) when ordering.)

Specifications	Length	Model
Optical Fiber Cable Connectors: S3200-COCF2511 ↓ S3200-COCF2511	2 m	S3200-CN201-25-25
	5 m	S3200-CN501-25-25
	10 m	S3200-CN102-25-25
	15 m	S3200-CN152-25-25
	20 m	S3200-CN202-25-25
	Over 20 m	S3200-CN-25-25 (Specify length (m) when ordering.)

**Note** Special training is required to assemble Optical Fiber Cables and connectors with epoxy adhesive. Contact your OMRON dealer for details on other optical fiber cords and cables.

## CPU Units and Peripheral Devices

### CPU Units

PC	Model number	Remarks
SYSMAC CS1	CS1H-CPU67/66/65/64/63 CS1G-CPU45/44/43/42	---
SYSMAC CV500, CV1000, or CV2000 PC (see note)	CV500-CPU01-EV1 CV1000-CPU01-EV1 CV2000-CPU01-EV1	Earlier versions of the CPU Units can also be used.
SYSMAC CVM1 PC (see note)	CVM1-CPU01-EV2 CVM1-CPU11-EV2 CVM1-CPU21-EV2	
SYSMAC C200HX, C200HG or C200HE PC	C200HE-CPU32/42-(Z)E C200HG-CPU33/43/53/63-(Z)E C200HX-CPU34/44/54/64-(Z)E	---

**Note** Routing tables are required if any of the CV-series CPU Units in the network have been manufactured on or before April 1996. The manufacturing data can be determined from the lot number on the side of the CPU Unit.

Lot No.: □ □ 4 6 . . . . . Manufactured in April 1996

Indicates the last digit of the manufacturing year. In this example, the year is 1996.

Indicates the month of manufacture. October, November, and December are indicated by x, y, and z respectively. In this example, the month is April.

### Peripheral Devices

Name	Model number	Remarks
Bus Connection Unit	C200HW-CE001	Required to connect a Controller Link Unit to a C200HX, C200HG, or C200HE CPU Unit.
	C200HW-CE002	Required to connect two Controller Link Units, or one Controller Link Unit and one other Communications Unit to a C200HX, C200HG, or C200HE CPU Unit.
	C200HW-CE012	Required to mount both a Controller Link Unit and a PC Card Unit to a C200HX, C200HG, or C200HE CPU Unit.
Communications Boards	C200HW-COM01 C200HW-COM04	Required to mount a Controller Link Unit to a C200HX, C200HG, or C200HE CPU Unit.

**Note** Refer to the operation manual for the relevant PC for further information on the above Peripheral Devices.

## Revision History

A manual revision code appears as a suffix to the catalog number on the front cover of the manual.

Cat. No. W307-E1-3

↑  
— Revision code

The following table outlines the changes made to the manual during each revision. Page numbers refer to the previous version.

Revision code	Date	Revised content
1	February 1997	Original production
2	June 1997	Removed "-HZ" model suffix throughout the manual.
3	February 1999	"Common memory" corrected to "shared memory" throughout the manual. Addition of new 3G8F5-CLK11-E optical model and optical system information throughout the manual. Addition of CS1-series PC information throughout the manual.