

SECTION 4

Commands and Responses

This section provides the command and response formats for all of the instructions covered by this manual. A table of the responses produced for different errors is included in *4-45 Response Code List*. Examples of communications between a Host Link Unit and PC, for several commands, are given at the end of the *4-46 Communications Examples*. The levels at which the commands are applicable are given in table form in *3-1 Command Levels*.

4-1	TEST	72
4-2	STATUS READ	72
4-3	ERROR READ	73
4-4	IR AREA READ	74
4-5	HR AREA READ	74
4-6	AR AREA READ	74
4-7	LR AREA READ	75
4-8	TC STATUS READ	75
4-9	DM AREA READ	76
4-10	FM INDEX READ	76
4-11	FM DATA READ	77
4-12	PV READ	77
4-13	SV READ 1	78
4-14	SV READ 2	79
4-15	SV READ 3	80
4-16	STATUS WRITE	81
4-17	IR AREA WRITE	81
4-18	HR AREA WRITE	82
4-19	AR AREA WRITE	82
4-20	LR AREA WRITE	82
4-21	TC STATUS WRITE	83
4-22	DM AREA WRITE	83
4-23	FM AREA WRITE	84
4-24	PV WRITE	84
4-25	SV CHANGE 1	85
4-26	SV CHANGE 2	86
4-27	SV CHANGE 3	87
4-28	FORCED SET	88
4-29	FORCED RESET	88
4-30	MULTIPLE FORCED SET/RESET	89
4-31	MULTIPLE FORCED SET/RESET STATUS READ	90
4-32	FORCED SET/RESET CANCEL	90
4-33	PC MODEL READ	91
4-34	DM HIGH-SPEED READ	91
4-35	ABORT and INITIALIZE	92
4-36	TRANSMIT (C200HS/HX/HG/HE only)	92
4-37	Response to an Undefined Command	92
4-38	Response Indicating an Unprocessed Command	93
4-39	PROGRAM READ	93
4-40	I/O TABLE READ	93
4-41	PROGRAM WRITE	94
4-42	I/O TABLE GENERATE	94
4-43	I/O REGISTER	95
4-44	I/O READ	96
4-45	Response Code List	97
4-46	Communications Examples	98

4-1 TEST

Transmits one block of data to the PC and then returns it, unaltered, to the host computer. Each frame is treated as a block regardless of whether it uses a terminator or delimiter.

Command Format

@	Unit no. X10 ¹ X10 ⁰	T	S	Any characters (122 max.) other than a carriage return	FCS	*	CR
---	---	---	---	--	-----	---	----

Response Format

@	Unit no. X10 ¹ X10 ⁰	T	S	Any characters (122 max.) other than a carriage return	FCS	*	CR
---	---	---	---	--	-----	---	----

Response if Error Occurs

@	Unit no. X10 ¹ X10 ⁰	T	S	Response code X16 ¹ X16 ⁰	*	CR
---	---	---	---	--	---	----

4-2 STATUS READ

Reads the operating status of the PC.

Command Format

@	Unit no. X10 ¹ X10 ⁰	M	S	FCS	*	CR
---	---	---	---	-----	---	----

Response Format

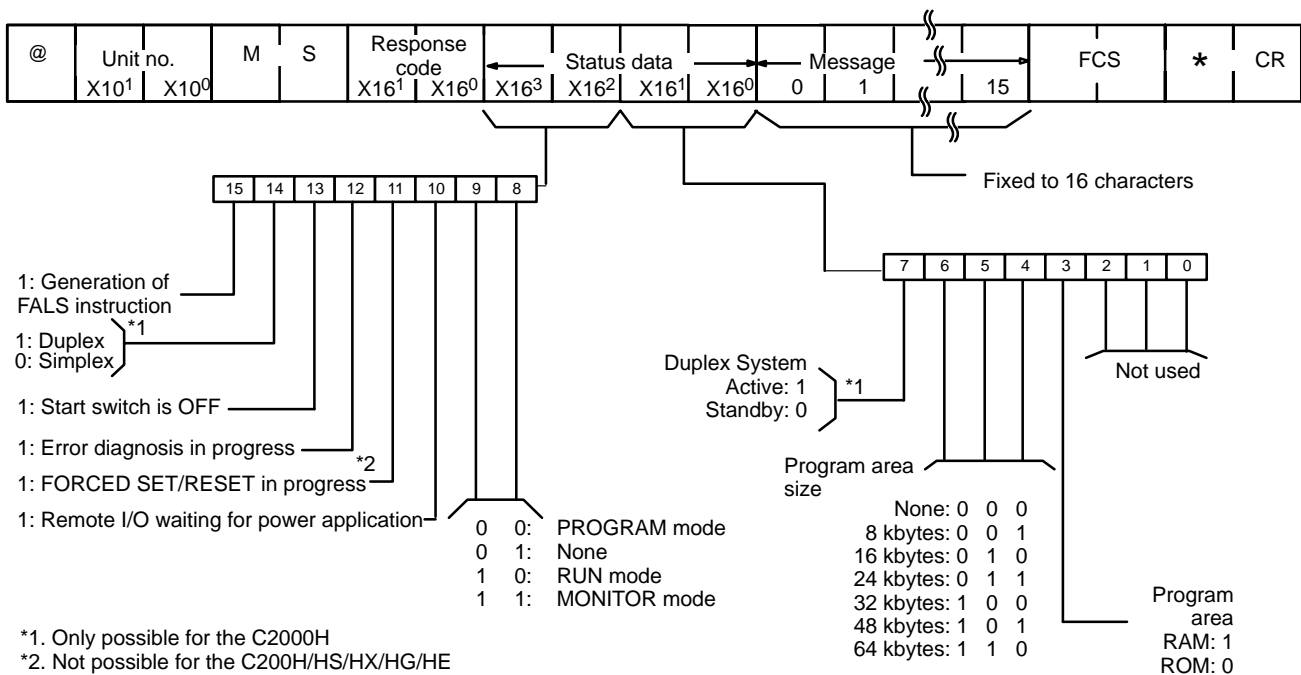

4-3 ERROR READ

Reads and clears errors in the PC. Also checks whether previous errors have already been cleared. When both Rack- and CPU-mounting Host Link Units are used in combination, errors in either type of Unit are indicated in the same manner.

Command Format

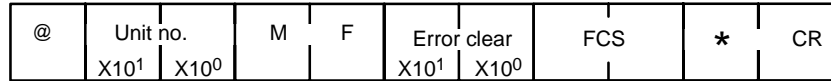

00: Error is not cleared
01: Error is cleared

Response Format

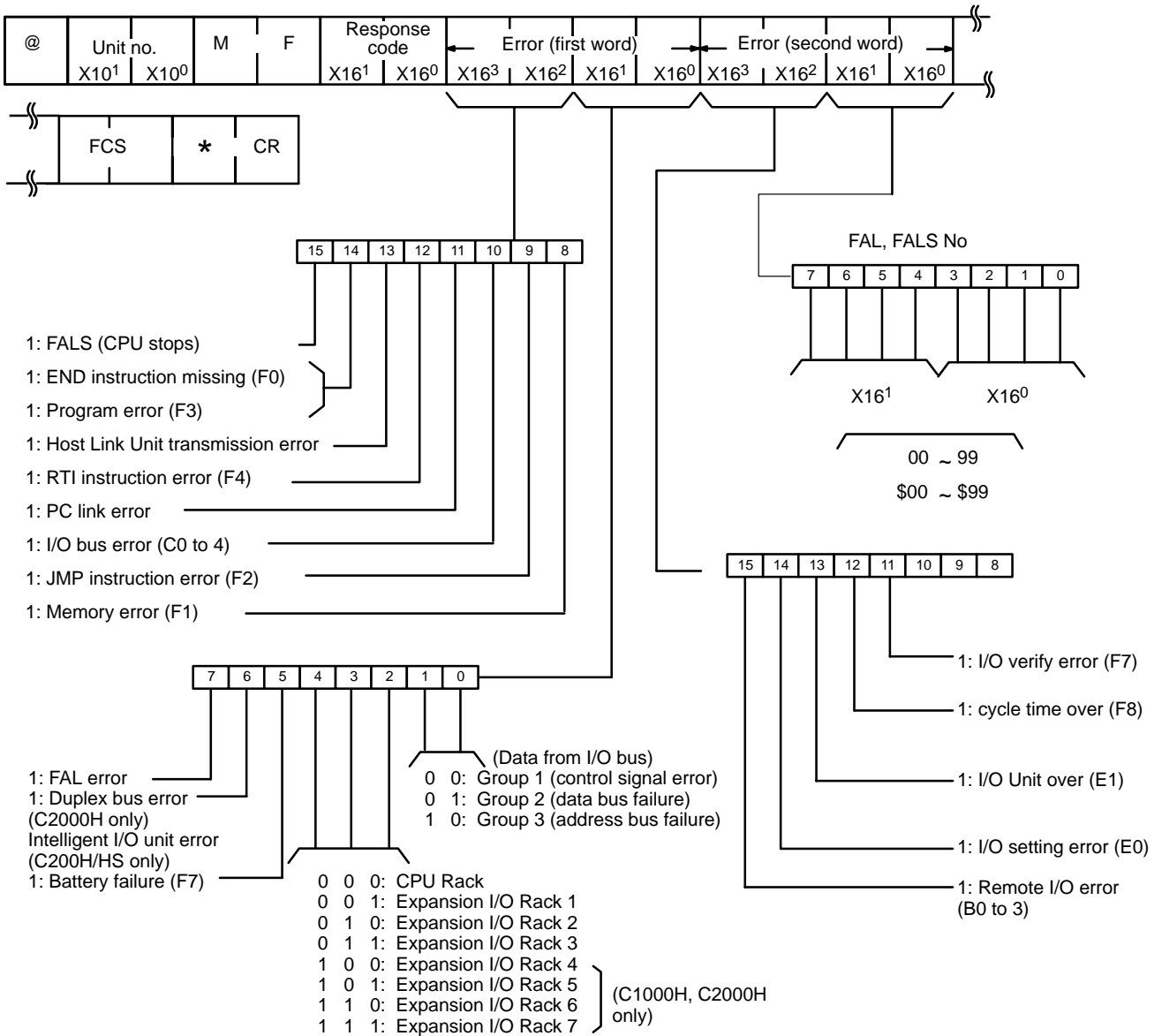

4-4 IR AREA READ

Reads the contents of the specified number of IR area words, starting from the specified word.

Command Format

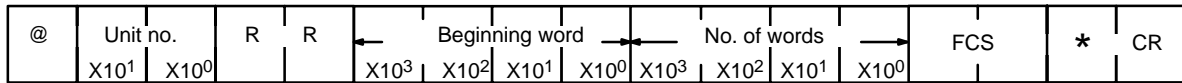

Response Format

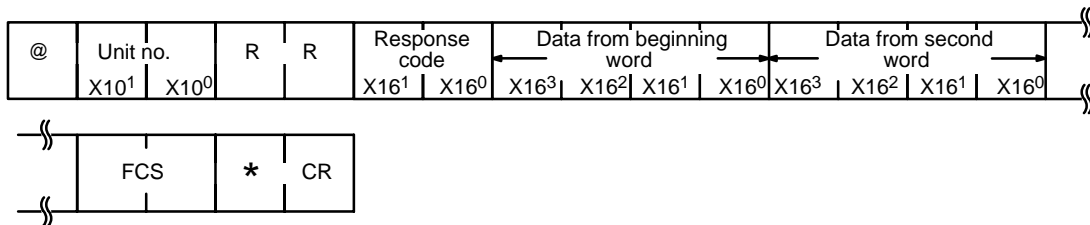

4-5 HR AREA READ

Reads the contents of the specified number of HR area words, starting from the specified word.

Command Format

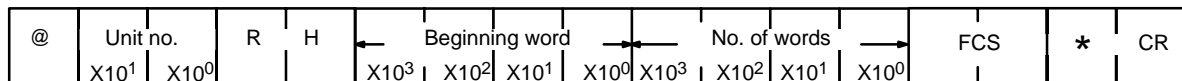

Response Format

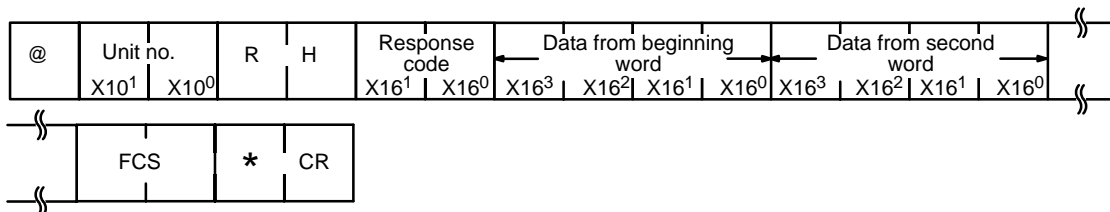

4-6 AR AREA READ

Reads the contents of the specified number of AR area words, starting from the specified word.

Command Format

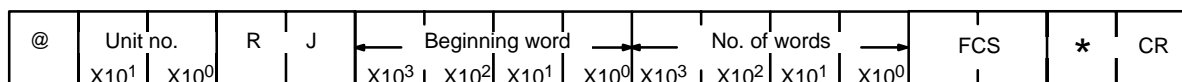

Response Format

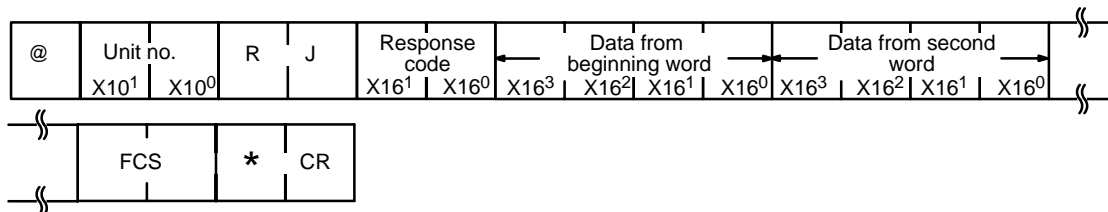

4-7 LR AREA READ

Reads the contents of the specified number of LR area words, starting from the specified word.

Command Format



Response Format

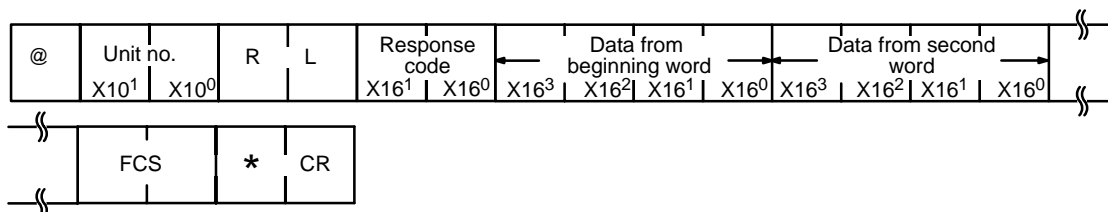

4-8 TC STATUS READ

Reads the status of the Completion Flags of the specified number of timers/counters, starting from the specified timer/counter.

Command Format

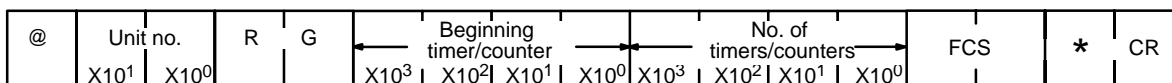

Response Format

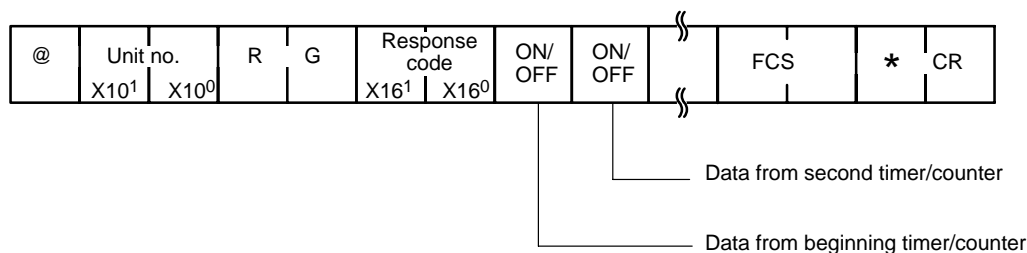

4-9 DM AREA READ

Reads the contents of the specified number of DM words, starting from the specified word.

Command Format

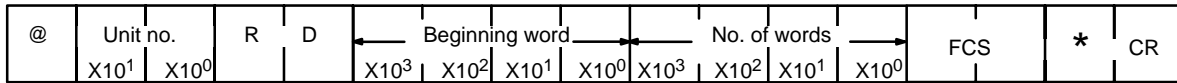

Response Format

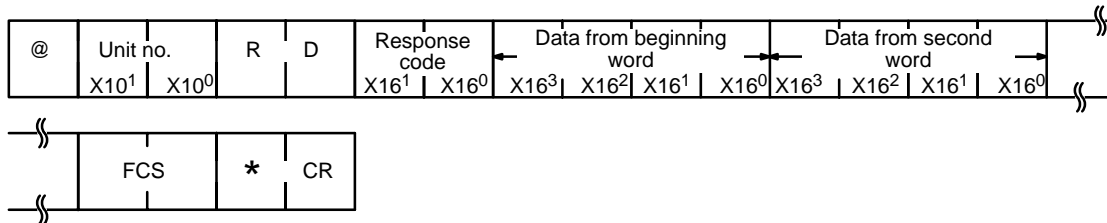

4-10 FM INDEX READ

Reads the contents of the specified number of FM index blocks, starting from the specified block.

Command Format

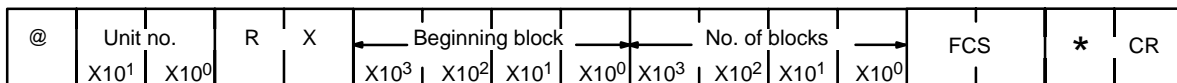

Response Format

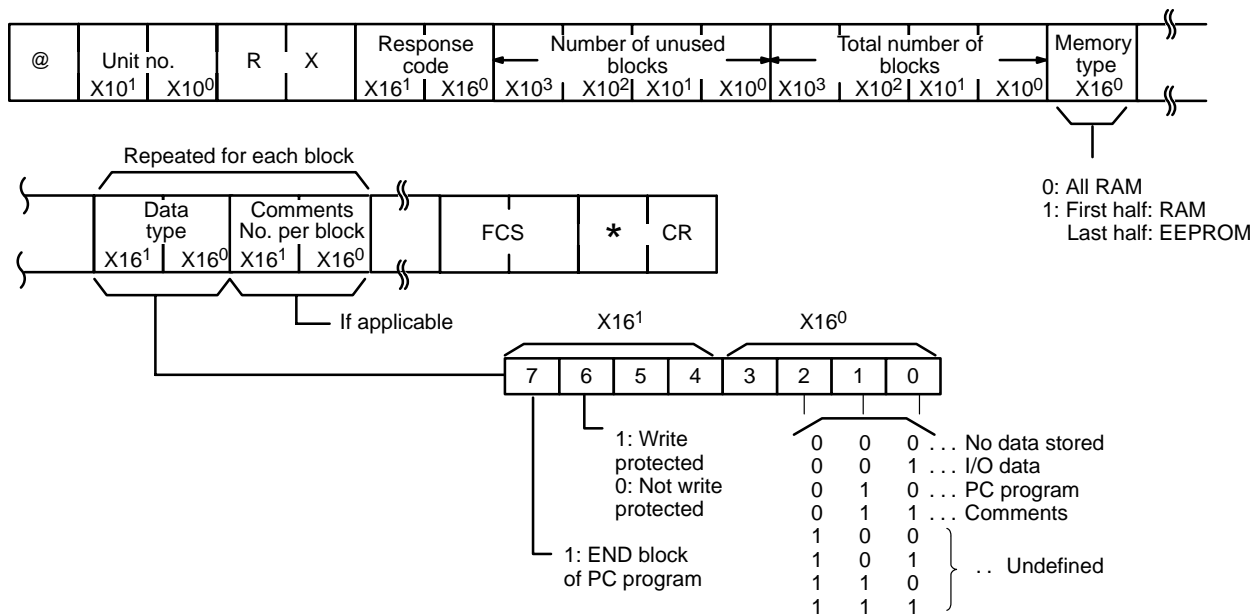

4-11 FM DATA READ

Reads the contents of the specified number of FM blocks, starting from the specified block. The “data type” and “comments per block” information can be added to each block, separated by a delineator, i.e., a comma (,).

Command Format

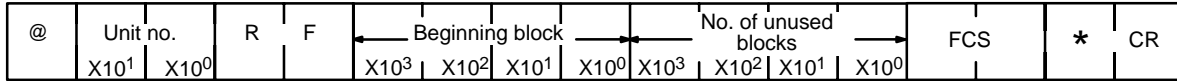

Response Format

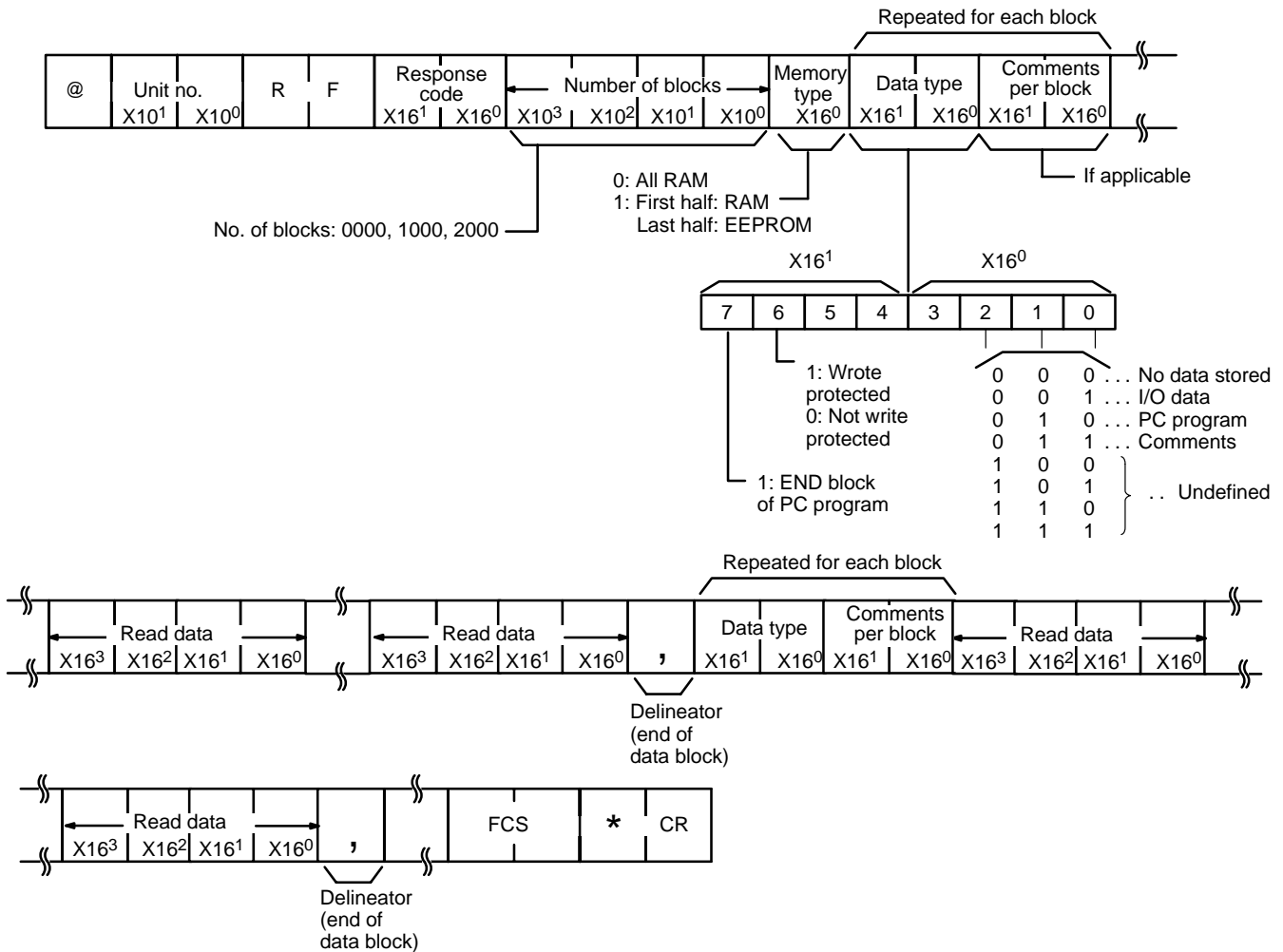

4-12 PV READ

Reads the specified number of timer/counter PVs (present values), starting from the specified timer/counter.

Command Format

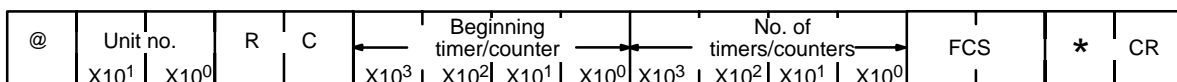

4-14 SV READ 2

Reads the set value (a constant, or data area and word) of the specified timer/counter instruction. The timer/counter instruction is designated by its program address. If the program has more than 9,999 addresses, use SV READ 3, described in the next section.

Command Format

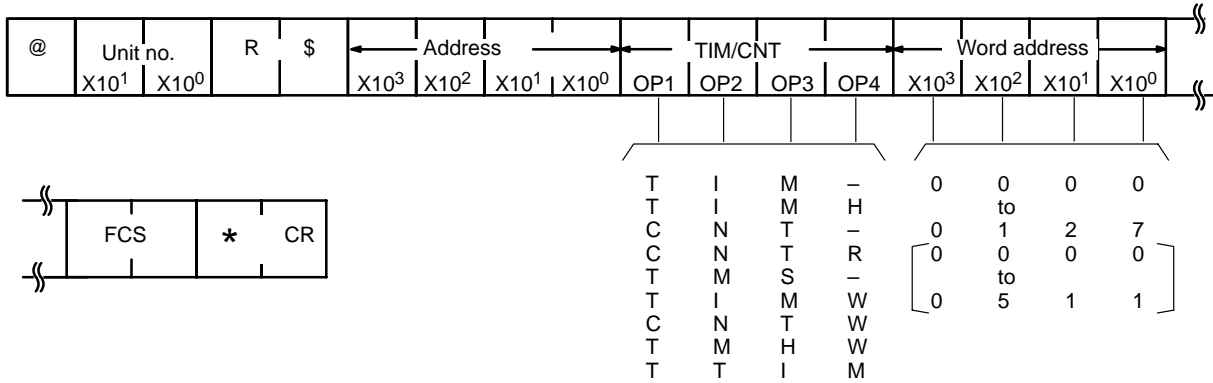

- Note**
1. Dashes represent spaces.
 2. The data in the brackets apply to the C200H, C200HS, C200HX, C200HG, C200HE, C1000H, and C2000H.

Response Format

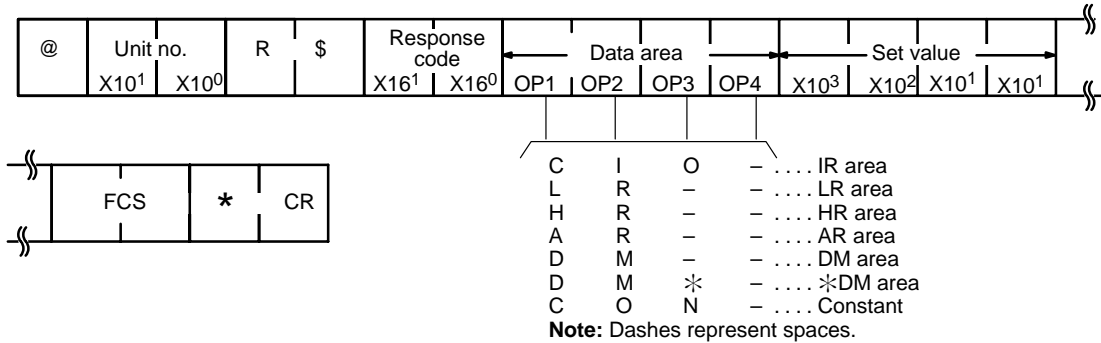

4-15 SV READ 3

Reads the set value (a constant, or data area and word) of the specified timer/counter instruction. The operation is similar to SV READ 2, but the SV READ 3 is capable of reading from higher program addresses (up to 6 digits).

Command Format

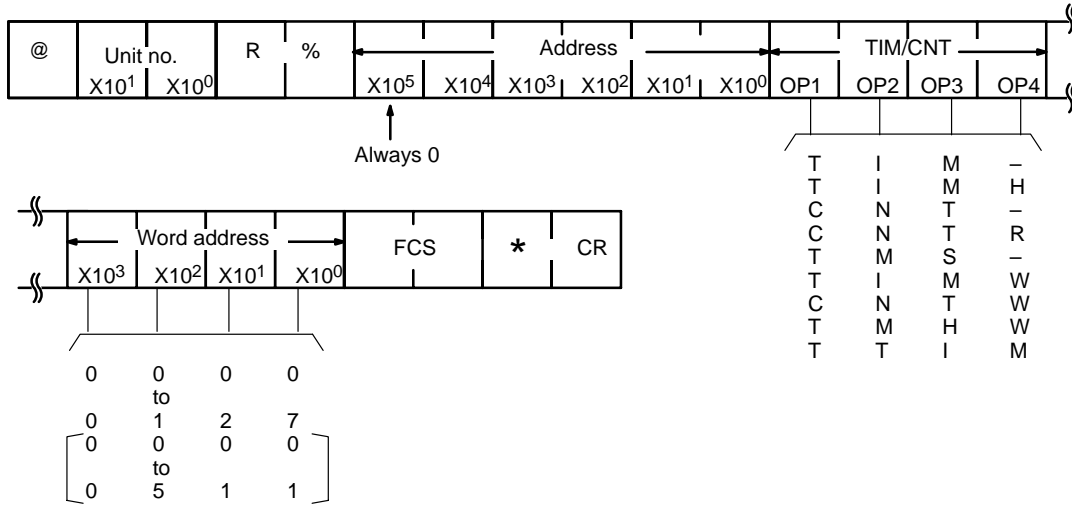

- Note**
1. Dashes represent spaces.
 2. The data in the brackets apply to the C200H, C200HS, C200HX, C200HG, C200HE, C1000H, and C2000H.

Response Format

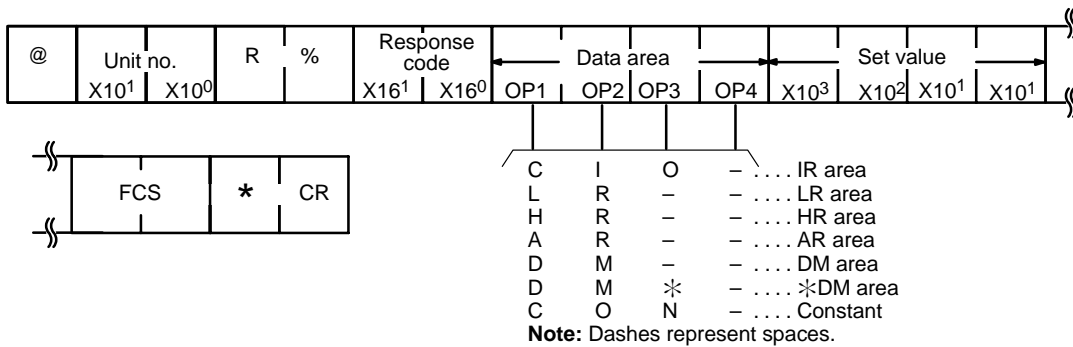

4-16 STATUS WRITE

Changes the operating mode of the PC according to the information entered into word X16⁰.

Command Format

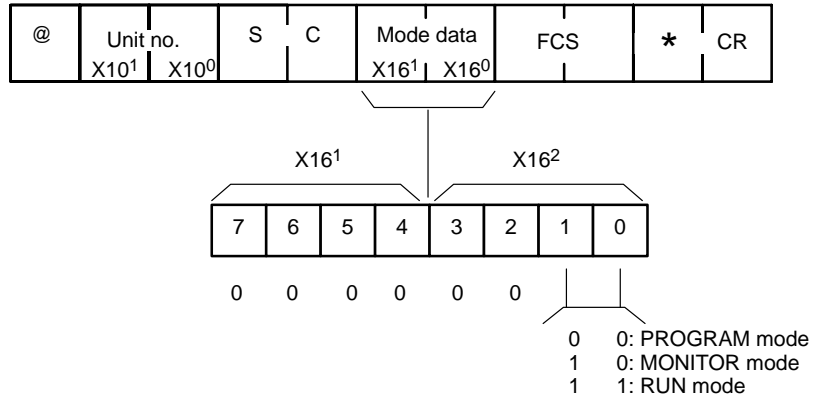

Response Format

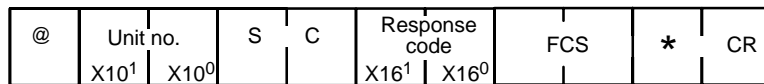

4-17 IR AREA WRITE

Writes data to the IR area, starting from the specified word. Writing is done word by word.

Command Format

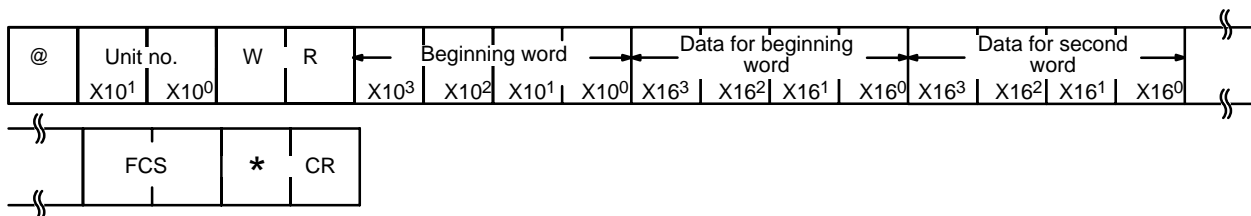

Response Format

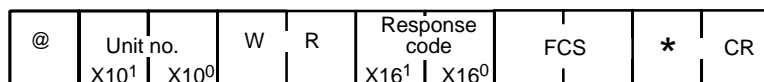

4-18 HR AREA WRITE

Writes data to the HR area, starting from the specified word. Writing is done word by word.

Command Format

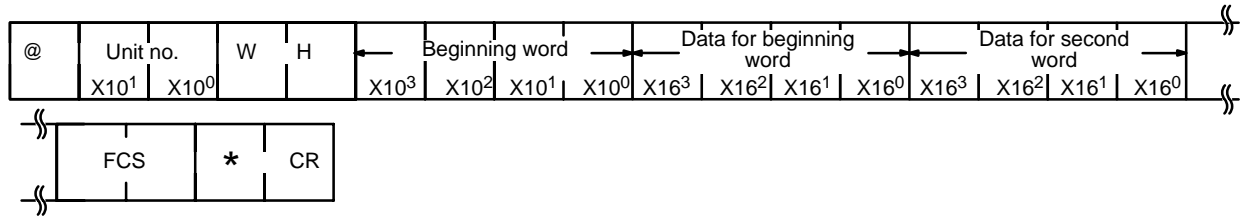

Response Format

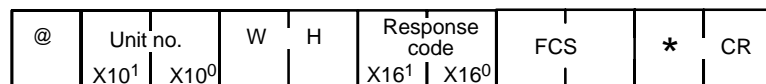

4-19 AR AREA WRITE

Writes data to the AR area, starting from the specified word. Writing is done word by word.

Command Format

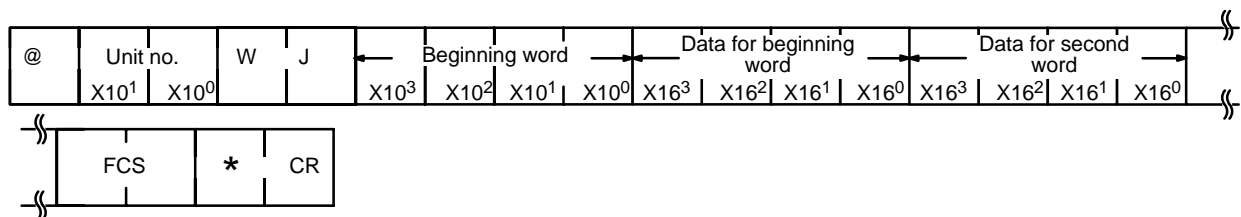

Response Format

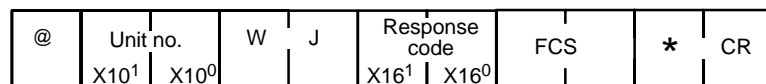

4-20 LR AREA WRITE

Writes data to the LR area, starting from the specified word. Writing is done word by word.

Command Format

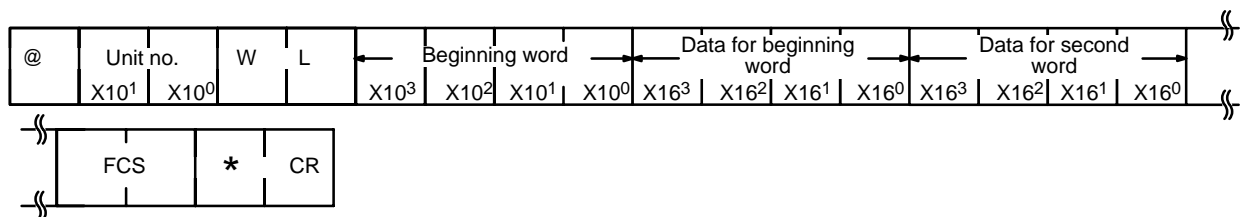

Response Format

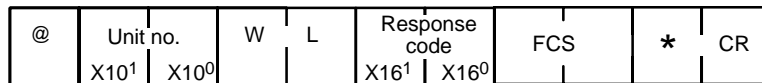

4-21 TC STATUS WRITE

Writes the status of the Completion Flags to the TC area, starting from the specified timer/counter.

Command Format

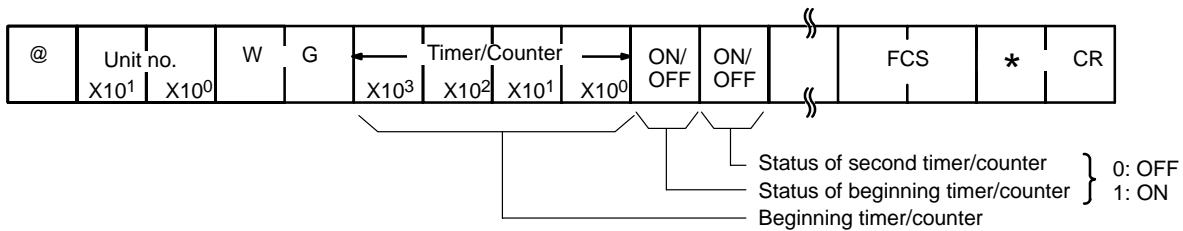

Response Format

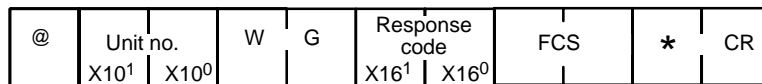

4-22 DM AREA WRITE

Writes data to the DM area, starting from the specified word. Writing is done word by word. If the Program Memory is in an EPROM chip, or if the write enable switch is set to OFF, the the writing range extends up to DM 0999 only.

Command Format

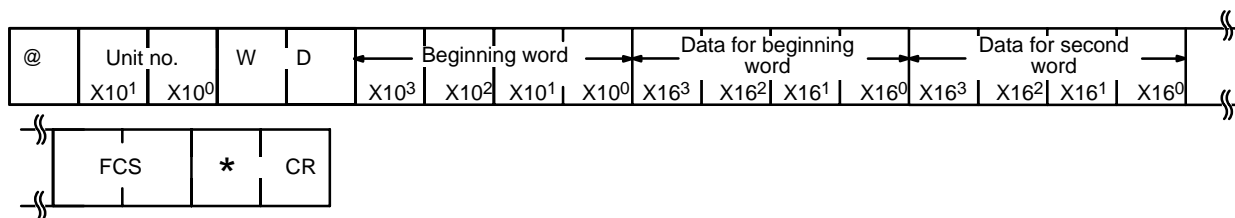

Response Format

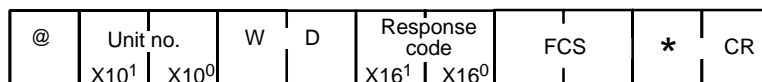

4-23 FM AREA WRITE

Writes data to a single specified word, or to an entire file memory block.

Command Format

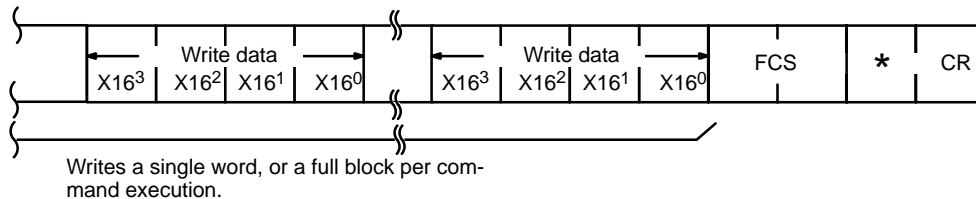
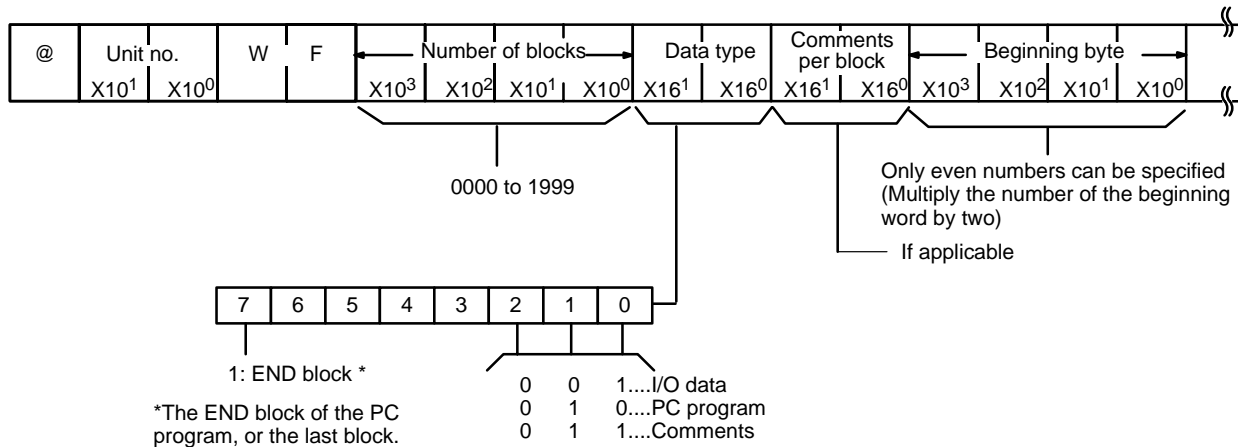

Response Format

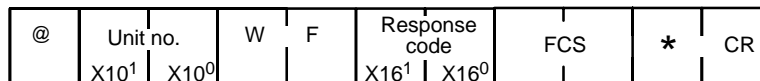

4-24 PV WRITE

Writes PVs (present values) of timers/counters, starting from the specified timer/counter.

Command Format

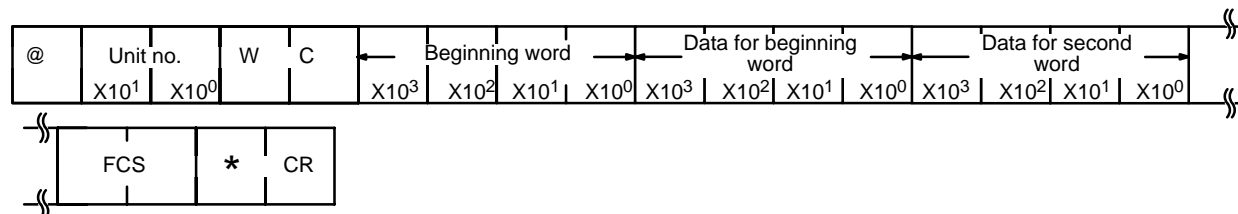

Response Format

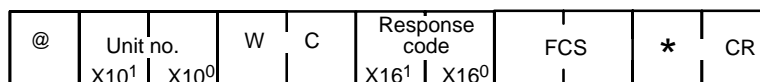

4-25 SV CHANGE 1

Changes the set value (constant only) of the specified timer/counter instruction. Reads from the beginning of the program and therefore take up to 20 seconds to produce a response. Refer also to 4-26 SV CHANGE 2 and 4-27 SV CHANGE 3.

Command Format

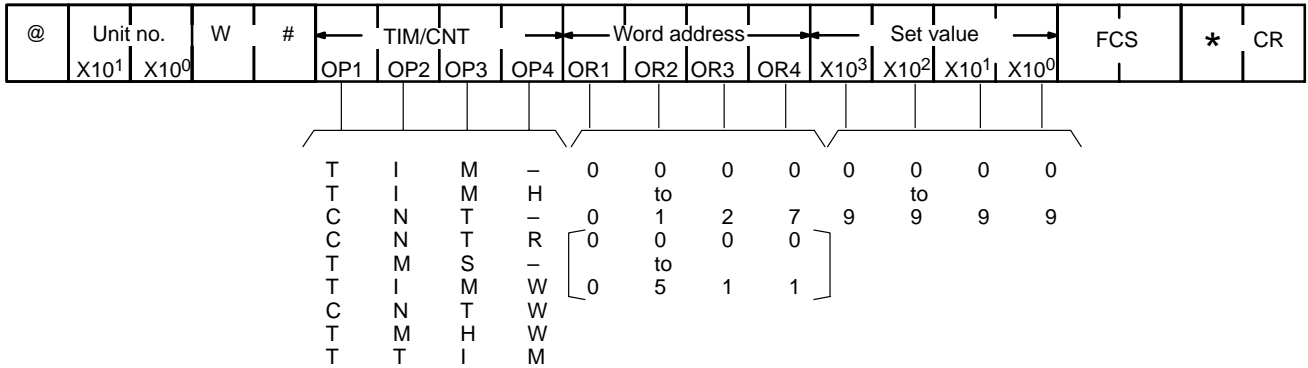

- Note**
1. Dashes represent spaces.
 2. The data in the brackets apply to the C200H, C200HS, C200HX, C200HG, C200HE, C1000H, and C2000H.

Response Format

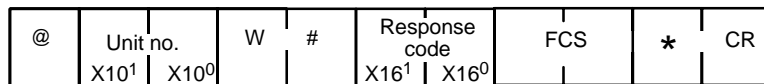

4-26 SV CHANGE 2

Changes the set value (a constant, or data area and word) of the specified timer/counter instruction. The instruction is specified by its program address. If the program has more than 9,999 addresses, use SV CHANGE 3, described in the next subsection.

Command Format

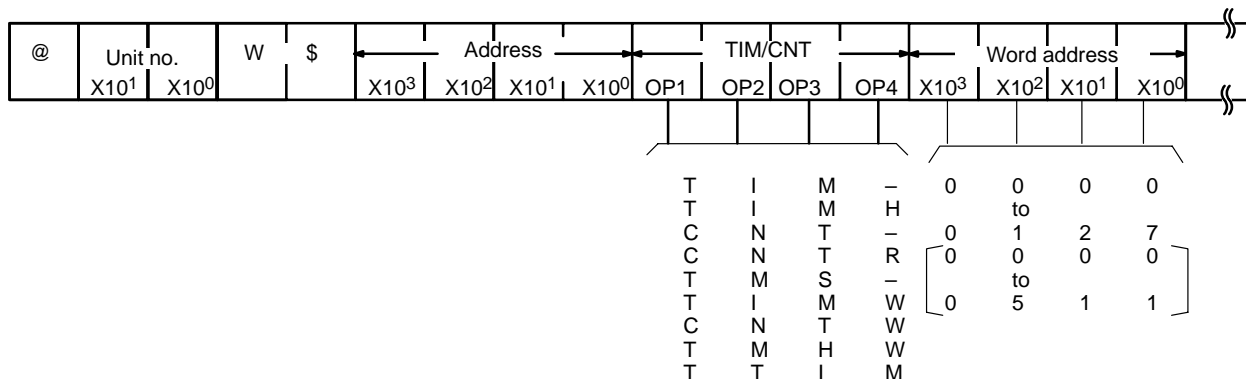

- Note**
1. Dashes represent spaces.
 2. The data in the brackets apply to the C200H, C200HS, C200HX, C200HG, C200HE, C1000H, and C2000H.

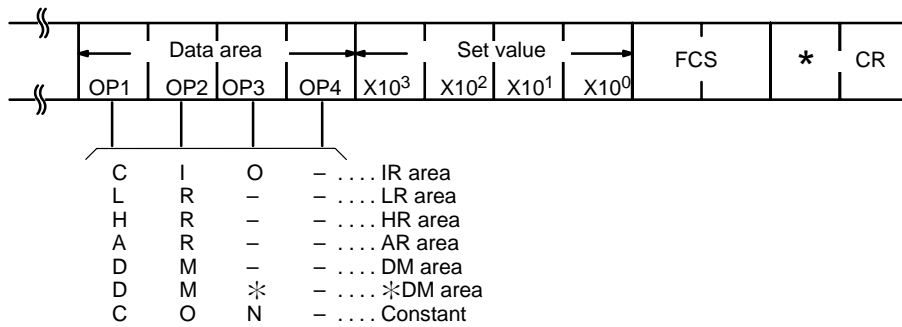

Note: Dashes represent spaces.

Response Format

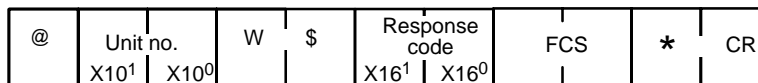

4-27 SV CHANGE 3

Changes the set value (a constant, or data area and word) of the specified instruction. The operation is similar to SV CHANGE 2, but SV CHANGE 3 can change SVs at higher program addresses (up to 5 digits, note that the leftmost, i.e., the sixth, address bit is always zero).

Command Format

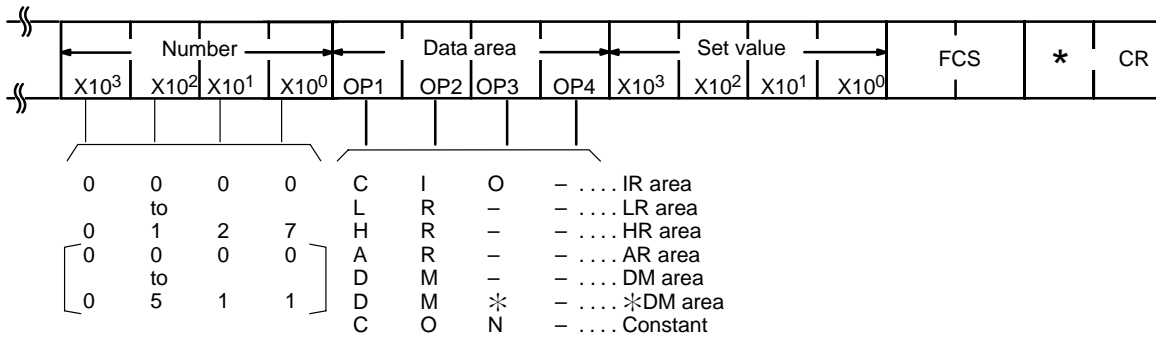
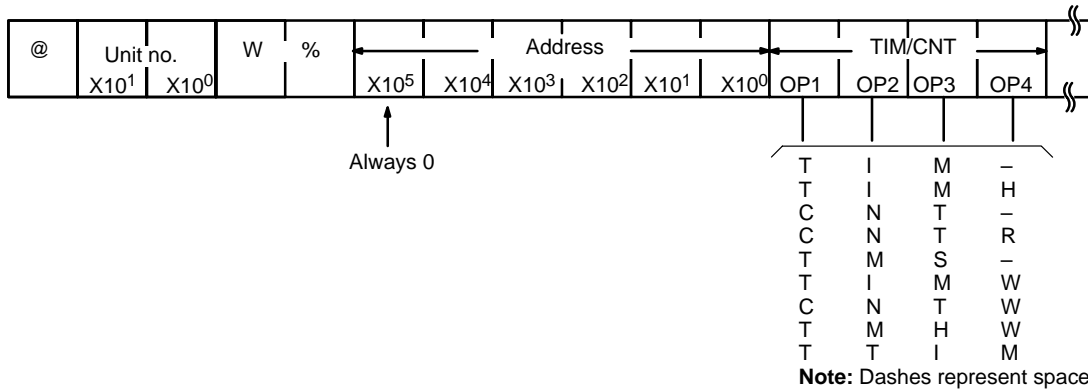

- Note**
1. Dashes represent spaces.
 2. The data in the brackets apply to the C200H, C200HS, C200HX, C200HG, C200HE, C1000H, and C2000H.

Response Format

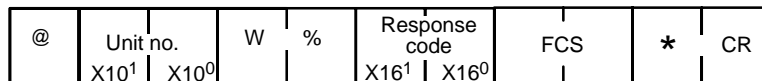

4-28 FORCED SET

Forced sets a bit in an IR, LR, HR, AR, or TC area. Bits need to be force set one at a time.

Command Format

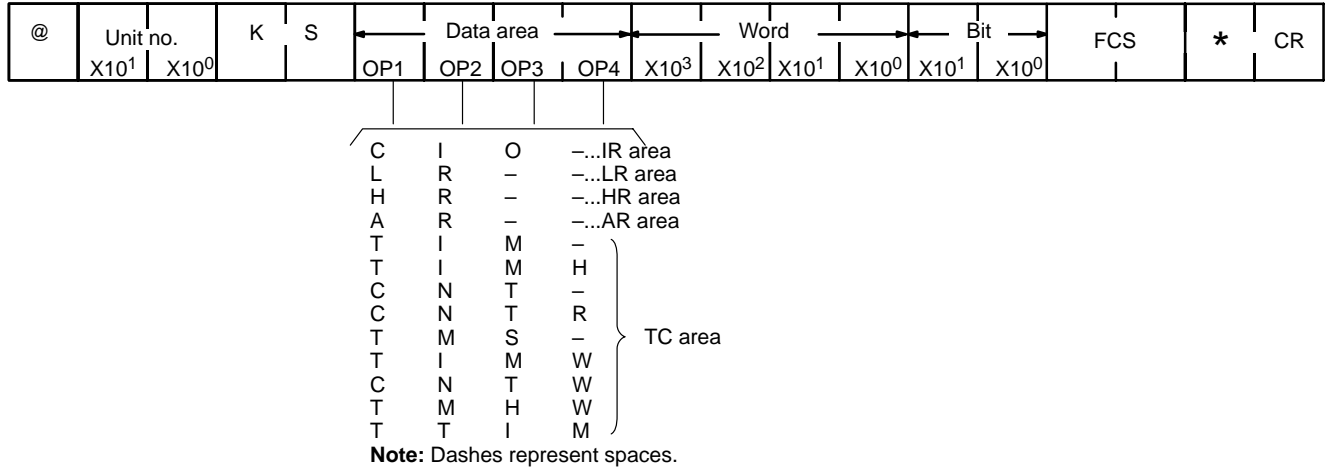

Response Format

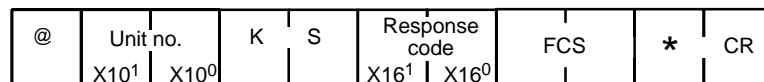

4-29 FORCED RESET

Force resets a bit in an IR, LR, HR, AR, or TC area. Bits can only be force reset one at a time. If an attempt is made to simultaneously force reset more than one bit, none of the bits will reset.

Command Format

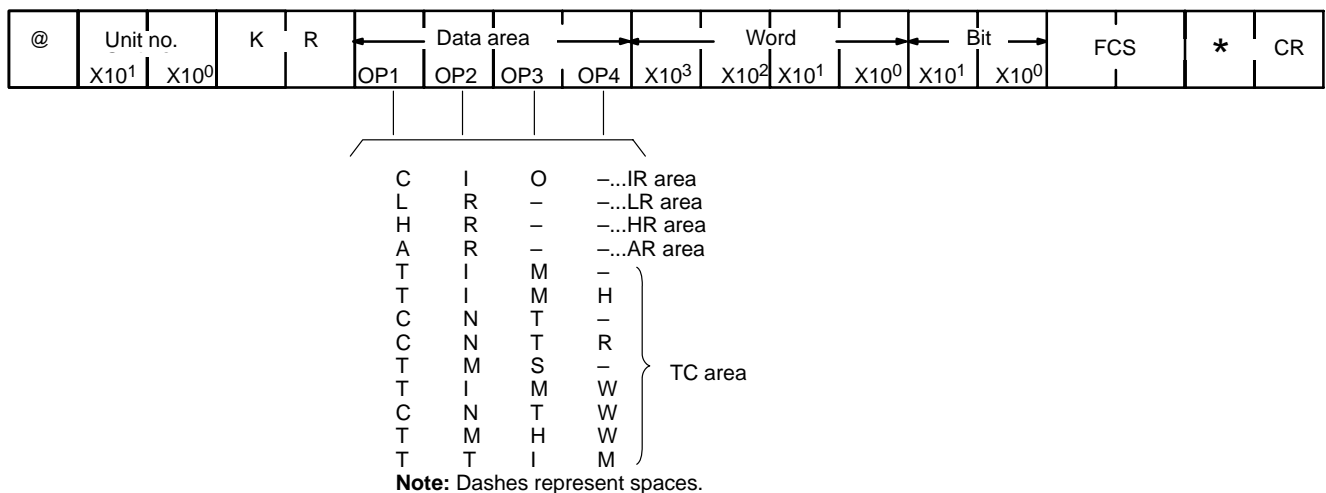

87Response Format

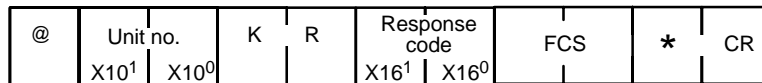

4-30 MULTIPLE FORCED SET/RESET

(C200H, C200HS, C200HX, C200HG, C200HE, and Mini H-type only.) This command force sets or resets bits in the IR, LR, HR, AR, or TC areas.

Command Format

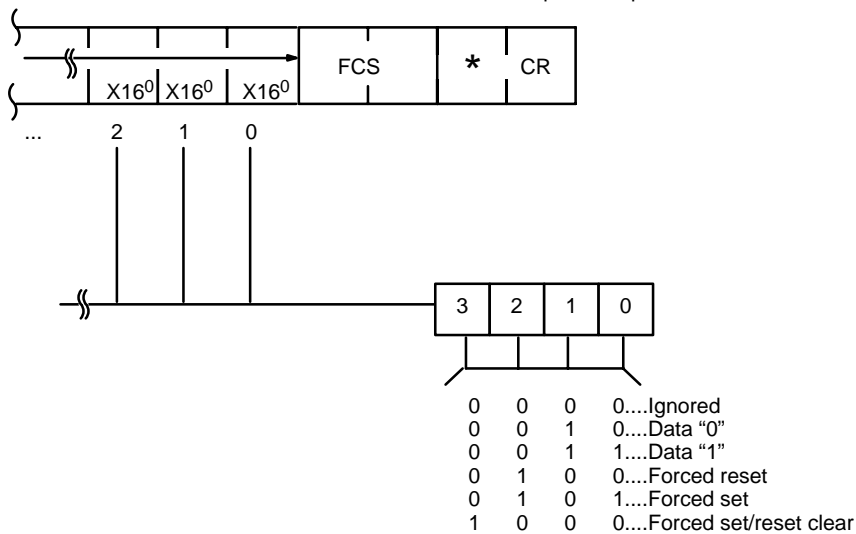
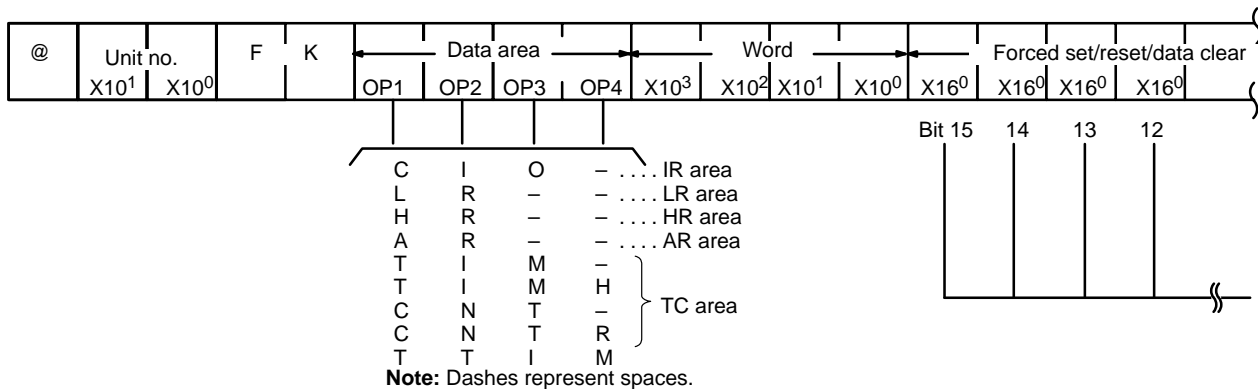

Response Format

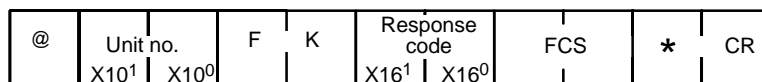

4-31 MULTIPLE FORCED SET/RESET STATUS READ

(C200H, C200HS, C200HX, C200HG, C200HE, and Mini H-type only.) Reads the forced set or forced reset status of the PC to which the specified Host Link Unit is mounted. When the operand is a timer/counter instruction (i.e., TIM(SP), TIMH, CNT(SP), CNTR, or TTIM), only the operands and words being force set/reset will be read.

Command Format



Response Format

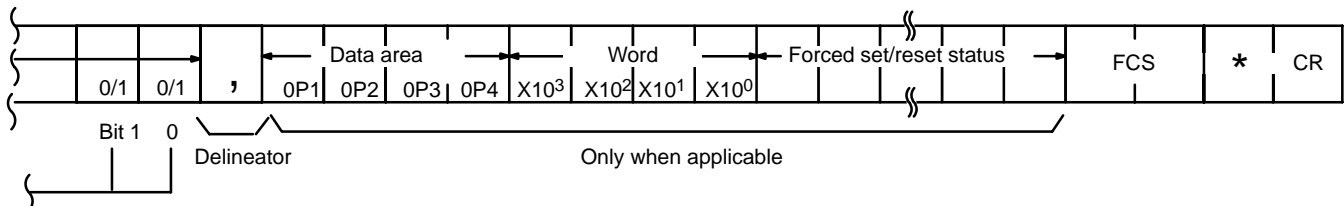
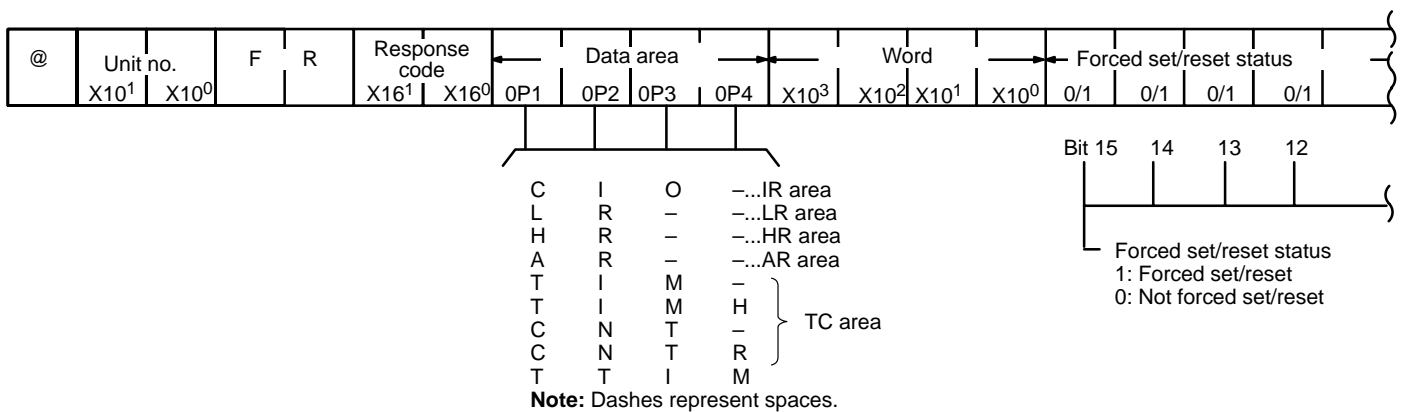

4-32 FORCED SET/RESET CANCEL

Cancels all forced set and forced reset bits (including those achieved via MULTIPLE FORCED SET/RESET for the C200H, C200HS, C200HX, C200HG, C200HE, and Mini H-type).

Command Format

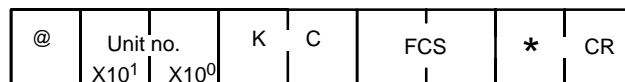

Response Format

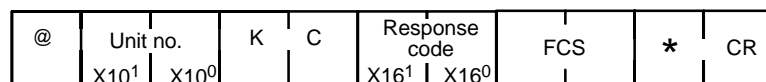

4-33 PC MODEL READ

Reads the model type of the PC.

Command Format



Response Format

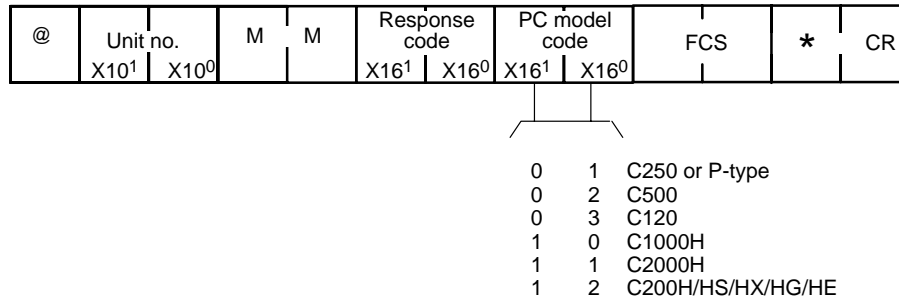

4-34 DM HIGH-SPEED READ

(C1000H and C2000H only) Reads a fixed group of eight DM area words at high-speed. The group of words to be read depends on the Host Link Unit and the PC as follows:

Host Link Unit		C1000H/C2000H
3G2A5-LK101-(P)EV1 3G2A5-LK201-EV1		Wd DM 0008 to 0015
C500-LK103(-P) C500-LK203	Operating level 0	Wd DM 0008 to 0015
	Operating level 1	Wd DM 0000 to 0007
3G2A6-LK101-(P)EV1 3G2A6-LK201-EV1 3G2A6-LK202-EV1		Wd DM 0016 to 0023

Command Format



Response Format

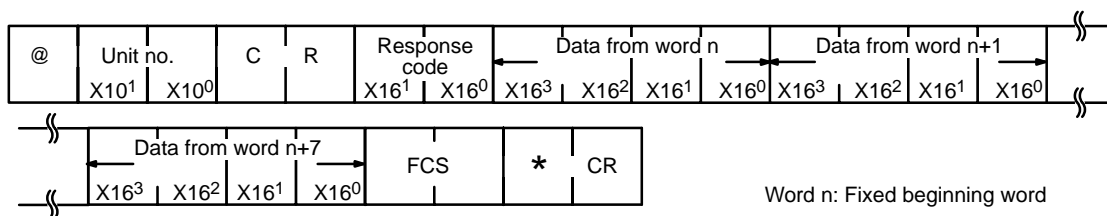

Response time is not affected by the operating mode of the PC or the cycle time. The response transmission begins less than 10 ms after the reception of the command.

4-35 ABORT and INITIALIZE

The ABORT command is used to abort the process being performed by the Host Link Unit and to then enable reception of the next command. The INITIALIZE command initializes the transmission control procedure of all the PCs connected to the host computer. Neither command receives a response.

A processing time of 100 ms is required between reception of the ABORT or INITIALIZE commands, and reception of the next command. If INITIALIZE is used in a single-link system, it will be regarded as undefined.

ABORT Command Format

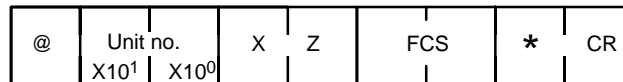

INITIALIZE Command Format

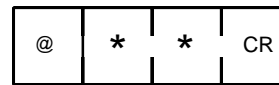

4-36 TRANSMIT (C200HS/HX/HG/HE only)

The Host Link Unit will transmit the specified data sent from the PC via the TXD (—) instruction in ASCII format. When the (TXD(—) instruction is executed in the ladder diagram, data is transmitted to the host computer in the following format. Refer to the *C200HS Operation Manual* or *C200HX/HG/HE Operation Manual* for further details on the TXD (—) instruction.

Response Format

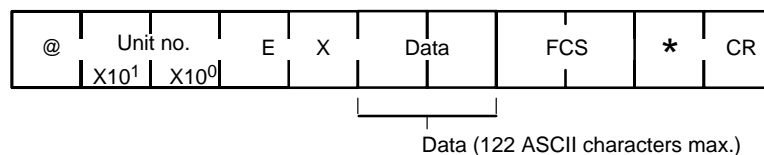

The data (61 bits maximum) specified in the operands of the TXD (—) instruction is converted into ASCII (122 characters maximum) and transmitted. There will be no response required from the host computer for TXD (—) instruction.

4-37 Response to an Undefined Command

This response is sent if the Host Link Unit cannot read the command's header code, or if the specified command is not valid for the command level or model of PC. If this response is received check the header code, command level, and PC model, then execute the correct command.

Response Format

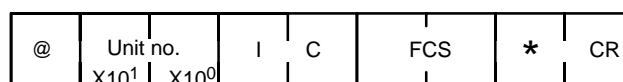

4-38 Response Indicating an Unprocessed Command

This response is sent when the Host Link Unit cannot process a command. The type of error encountered by the Host Link Unit can be identified via the response code.

Response Format

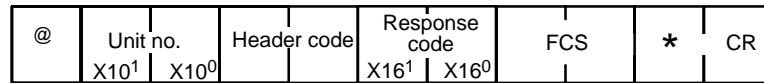

The header code varies according to the command which was sent. The headers of some commands include subheader codes (e.g., I/O REGISTER, I/O READ, and DM SIZE CHANGE).

4-39 PROGRAM READ

Transmits the contents of the PC program memory.

Command Format



Response Format

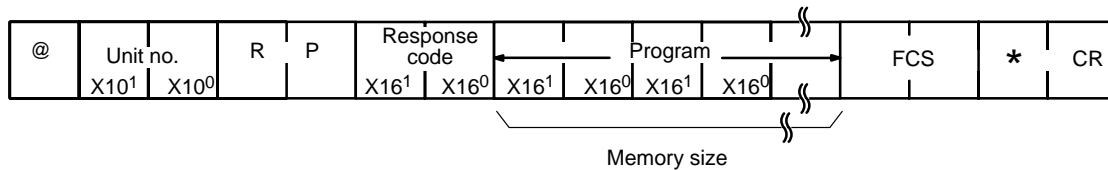

4-40 I/O TABLE READ

Reads the registered I/O table and the actual I/O table (i.e., the I/O Unit configuration connected to the PC).

Command Format



Response Format



	<u>Registered I/O table</u>	<u>Actual I/O table</u>
C1000H/C2000H, C200H:	930	1408 characters
All others:	336	358

4-41 PROGRAM WRITE

Writes the received program into the PC program memory.

Command Format

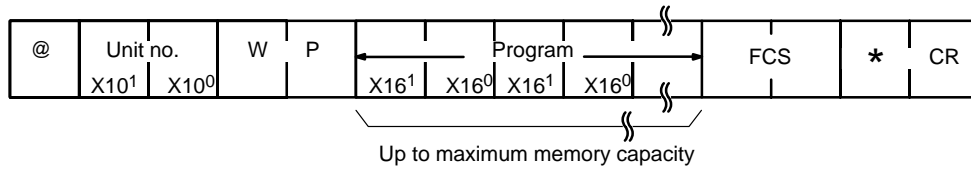

Response Format

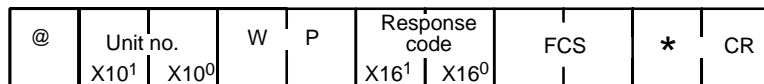

4-42 I/O TABLE GENERATE

Corrects the registered I/O table to match the actual I/O table.

Command Format

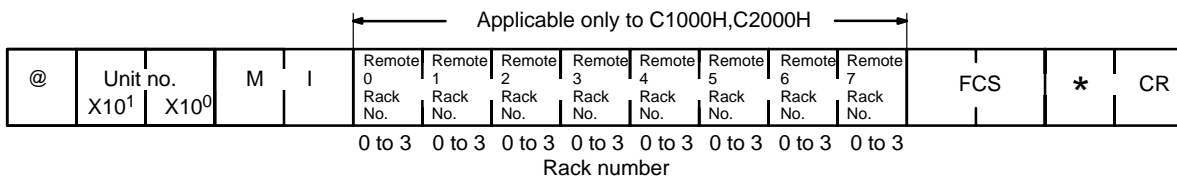

Note When the Rack number is to remain unspecified, assign an ASCII character other than 0 to 3 to it.

Response Format

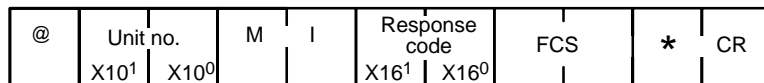

4-43 I/O REGISTER

Registers the IR, LR, HR, AR, or TC area bit, or the DM word that is to be read via I/O READ (described in the next subsection). Registered data is retained until new data is registered, or the power is turned OFF.

Command Format

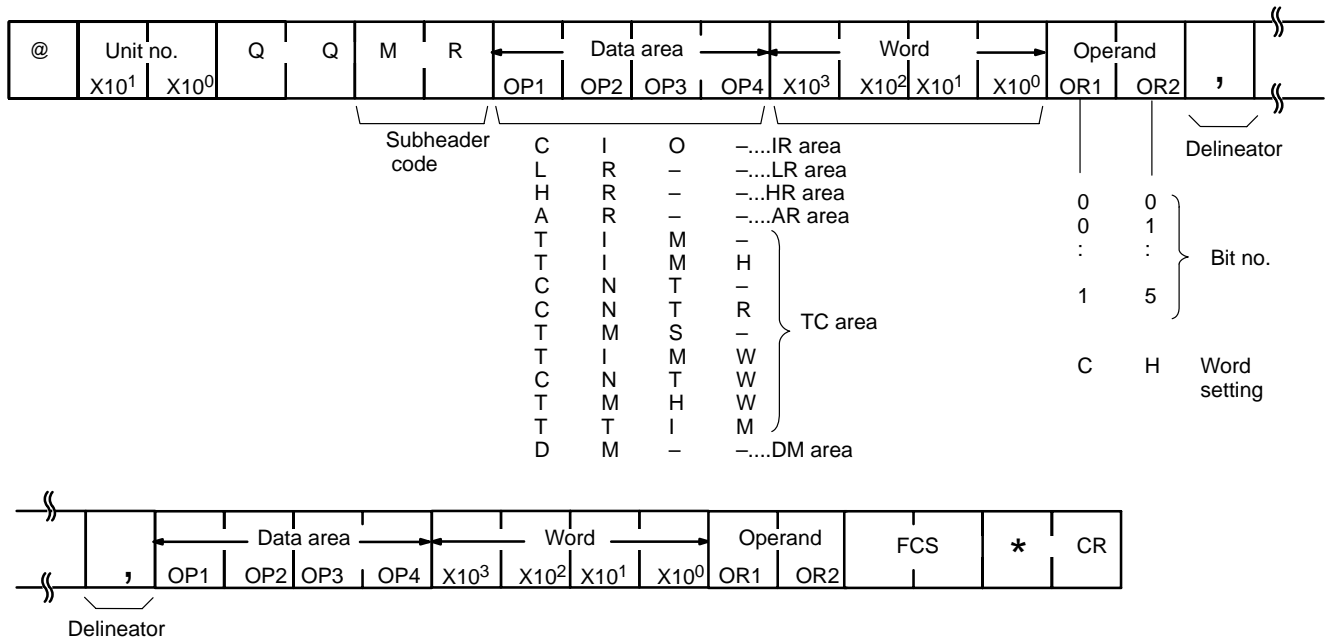

Setting Table

	Data Area	Word	Operand	Response
Bit	IR	0000 to max. Wd	00 to 15	ON/OFF status of specified bit
	LR	0000 to max. Wd	00 to 15	ON/OFF status of specified bit
	HR	0000 to max. Wd	00 to 15	ON/OFF status of specified bit
	AR	0000 to max. Wd	00 to 15	ON/OFF status of specified bit
	TIM/CNT	0000 to max. Wd	Anything other than "CH"	ON/OFF status of specified bit
Wd	IR	0000 to max. Wd	"CH"	Word contents
	LR	0000 to max. Wd	"CH"	Word contents
	HR	0000 to max. Wd	"CH"	Word contents
	AR	0000 to max. Wd	"CH"	Word contents
	TIM/CNT	0000 to max. Wd	"CH"	ON/OFF status of Completion Flag and PV
	DM	0000 to max. Wd	Any characters	Word contents

The maximum number of data items for the C120 and C500 PCs is 140; and for the C200H, C200HS, C200HX, C200HG, C200HE, C1000H, C2000H PCs the maximum is 128. However, the C200H, C200HS, C200HX, C200HG, C200HE, C1000H, C2000H PCs count the TC area word specification as two items.

The data is registered in the same sequence in which it was specified.

Response Format

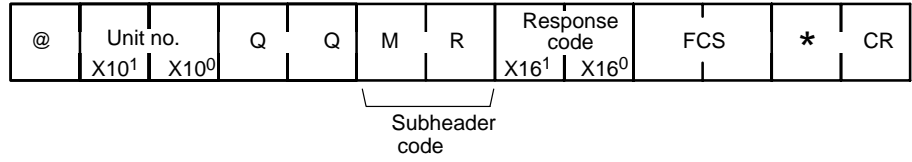

4-44 I/O READ

Reads the data specified by I/O REGISTER.

Command Format

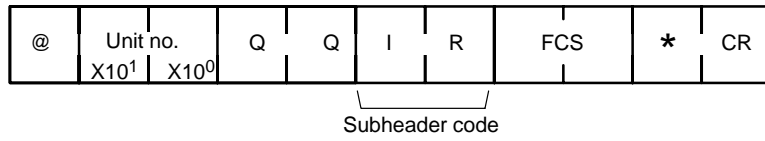

Response Format

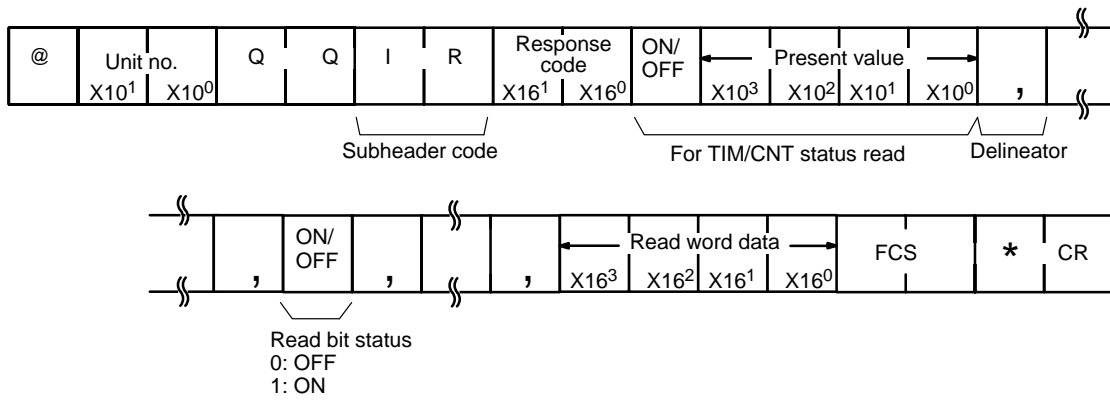

4-45 Response Code List

A response code is returned with each response to a command to indicate the results of executing the command. A response code of 00 indicates that the command was completed normally. All other response codes indicate errors that prevented proper command execution and tell something about the cause of the error.

x16 ¹	x16 ⁰	Description
0	0	Command completed normally.
0	1	Execution was not possible because the PC is in RUN mode. Change the PC mode.
0	2	Execution was not possible because the PC is in MONITOR mode. Change the PC mode.
0	3	Execution was not possible because PROM is mounted. Change the unit to RAM or EEPROM.
0	4	Address overflow (data overflow). Check the program.
0	B	Execution was not possible because the PC is in PROGRAM mode. Change the PC mode.
0	C	Execution was not possible because the PC is in DEBUG mode. Change the PC mode.
0	D	Execution was not possible because the Host Link Unit's keyswitch is set to LOCAL mode or because the command was sent to a C2000H CPU that was on standby. Change the mode or send the command to the active CPU.
1	0	Parity error.
1	1	Framing error (stop bit(s) not detected).
1	2	Overrun (the next command was received too soon).
1	3	FCS error (checksum error).
1	4	Command format error.
1	5	An incorrect data area designation was made for READ or WRITE.
1	6	Instruction not found.
1	8	Frame length error (maximum length exceeded).
1	9	Execution was not possible because of an unexecutable error clear, memory error, EEPROM write disabled, etc.
2	0	I/O table generation was not possible (unrecognized Remote I/O Unit, word overflow, duplicated word allocation).
2	1	An error occurred in the PC's CPU.
2	2	The specified Memory Unit does not exist.
2	3	The specified Memory Unit is write-protected.
A	0	Aborted due to parity error in transmit data.
A	1	Aborted due to framing error in transmit data.
A	2	Aborted due to overrun in transmit data.
A	3	Aborted due to FCS (checksum) error in transmit data.
A	4	Aborted due to format error in transmit data.
A	5	Aborted due to entry number data error in transmit data.
A	8	Aborted due to frame length error in transmit data.
B	0	Not executable because the program area is not 16 kbytes.
Other		Remove any possible causes of noise and resend the command.